



**THE DATASHEET OF
TLP521-1(GB,F)**





ISOCOM
COMPONENTS

TLP521, TLP521-2, TLP521-4



DESCRIPTION

The TLP521, TLP521-2 and TLP521-4 series of optically coupled isolator consist of an infrared light emitting diode and an NPN silicon photo transistor in a space efficient Dual In Line Plastic Package.

FEATURES

- AC Isolation Voltage 5300V_{RMS}
- CTR Selections Available
- Wide Operating Temperature Range
-30°C to +100°C
- Lead Free and RoHS Compliant
- UL File E91231 Package Code "EE"
- VDE Approval Certificate No. 40028086

APPLICATIONS

- Computer Terminals
- Industrial System Controllers
- Measuring Instruments
- Signal Transmission between Systems of Different Potentials and Impedances

ORDER INFORMATION

- Add X after PN for VDE Approval
- Add G after PN for 10mm lead spacing
- Add SM after PN for Surface Mount
- Add SMT&R after PN for Surface Mount Tape & Reel
(Available for TLP521SM and TLP521-2SM)
- Optional Order Part No. TLP521-1 for TLP521
- Consult Factory for Tape and Reel version of TLP521-4SM

TLP521



TLP521-2



TLP521-4



ABSOLUTE MAXIMUM RATINGS (T_A = 25°C)

Stresses exceeding the absolute maximum ratings can cause permanent damage to the device.

Exposure to absolute maximum ratings for long periods of time can adversely affect reliability.

Input

Forward Current	50mA
Reverse Voltage	6V
Power dissipation	70mW

Output

Collector to Emitter Voltage BV _{CEO}	55V
Emitter to Collector Voltage BV _{ECO}	6V
Collector Current	50mA
Power Dissipation	150mW

Total Package

Isolation Voltage	5300V _{RMS}
Total Power Dissipation	200mW
Operating Temperature	-30 to 100 °C
Storage Temperature	-55 to 125 °C
Lead Soldering Temperature (10s)	260°C

ISOCOM COMPONENTS 2004 LTD

Unit 25B, Park View Road West, Park View Industrial Estate
Hartlepool, Cleveland, TS25 1PE, United Kingdom
Tel : +44 (0)1429 863 609 Fax : +44 (0)1429 863 581
e-mail : sales@isocom.co.uk
<http://www.isocom.com>

ISOCOM COMPONENTS ASIA LTD

Hong Kong Office
Block A, 8/F, Wah Hing Industrial Mansion
36 Tai Yau Street, San Po Kong, Kowloon, Hong Kong
Tel : +852 2995 9217 Fax : +852 8161 6292
e-mail : sales@isocom.com.hk



TLP521, TLP521-2, TLP521-4

ELECTRICAL CHARACTERISTICS (Ambient Temperature = 25°C unless otherwise specified)

INPUT

Parameter	Symbol	Test Condition	Min	Typ.	Max	Unit
Forward Voltage	V_F	$I_F = 10\text{mA}$	1.0	1.15	1.3	V
Reverse Voltage	V_R	$I_R = 10\mu\text{A}$	6.0			V
Reverse Leakage	I_R	$V_R = 4\text{V}$			10	μA
Terminal Capacitance	C_t	$V = 0\text{V}, f = 1\text{KHz}$		30	250	pF

OUTPUT

Parameter	Symbol	Test Condition	Min	Typ.	Max	Unit
Collector—Emitter breakdown Voltage	BV_{CEO}	$I_C = 0.5\text{mA}, I_F = 0\text{mA}$	55			V
Emitter—Collector breakdown Voltage	BV_{ECO}	$I_E = 100\mu\text{A}, I_F = 0\text{mA}$	6			V
Collector-Emitter Dark Current	I_{CEO}	$V_{CE} = 20\text{V}, I_F = 0\text{mA}$			100	nA



TLP521, TLP521-2, TLP521-4

ELECTRICAL CHARACTERISTICS (Ambient Temperature = 25°C unless otherwise specified)

COUPLED

Parameter	Symbol	Test Condition	Min	Typ.	Max	Unit
Current Transfer Ratio	CTR	$I_F = 5\text{mA}, V_{CE} = 5\text{V}$	50		600	%
		Optional CTR Grades				
		GR	100		300	
		BL	200		600	
		GB	100		600	
		GB ($I_F = 1\text{mA}, V_{CE} = 0.4\text{V}$)	30			
Collector—Emitter Saturation Voltage	$V_{CE(sat)}$	$I_F = 8\text{mA}, I_C = 2.4\text{mA}$ GB ($I_F = 1\text{mA}, I_C = 0.2\text{mA}$)			0.4 0.4	V
Output Rise Time	t_r	$V_{CE} = 2\text{V},$ $I_C = 2\text{mA},$ $R_L = 100\Omega$		4		μs
Output Fall Time	t_f			3		
Turn-on Time	t_{on}			3		
Turn-off Time	t_{off}			3		
Turn-on Time	t_{ON}	$V_{CC} = 5\text{V},$ $I_F = 16\text{mA},$ $R_L = 1.9\text{k}\Omega$		2		μs
Turn-off Time	t_{OFF}			25		

ISOLATION

Parameter	Symbol	Test Condition	Min	Typ.	Max	Unit
Input to Output Isolation Voltage	V_{ISO}	AC 1 minute, RH = 40 to 60% Note 1	5300			V_{RMS}
Input to Output Isolation Resistance	R_{ISO}	$V_{IO} = 500\text{V}$ Note 1	5×10^{10}			Ω

Note 1 : Measure with input leads shorted together and output leads shorted together.



TLP521, TLP521-2, TLP521-4



Fig 1 Forward Current vs T_A



Fig 2 Collector Power Dissipation vs T_A

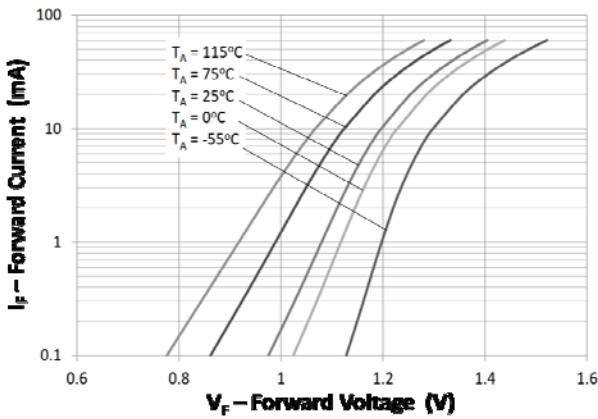

Fig 3 Forward Current vs Forward Voltage



Fig 4 Collector Current vs Collector-Emitter Voltage

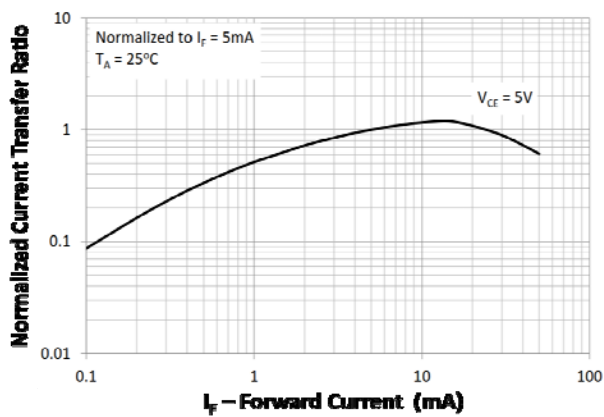

Fig 5 Normalized Current Transfer Ratio vs Forward Current



Fig 6 Normalized Current Transfer Ratio vs Ambient Temperature



TLP521, TLP521-2, TLP521-4

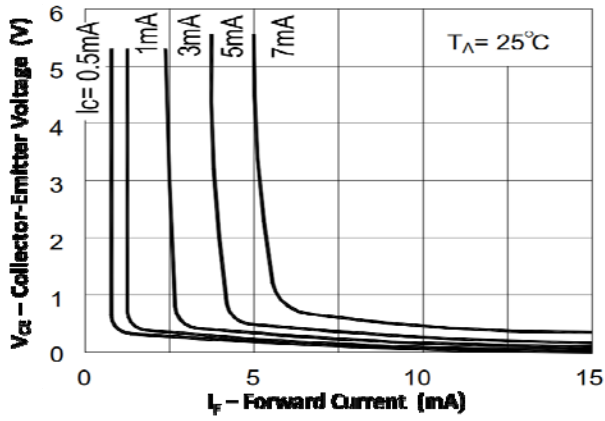

Fig 7 Collector-Emitter Voltage vs Forward Current

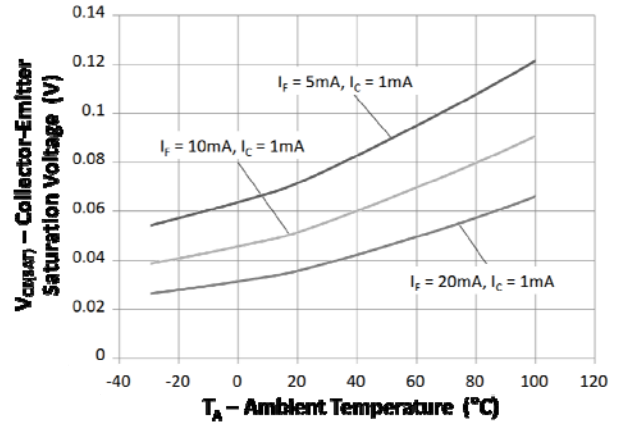

Fig 8 Collector-Emitter Voltage vs Ambient Temperature



Fig 9 Collector Dark Current vs Ambient Temperature



TLP521, TLP521-2, TLP521-4

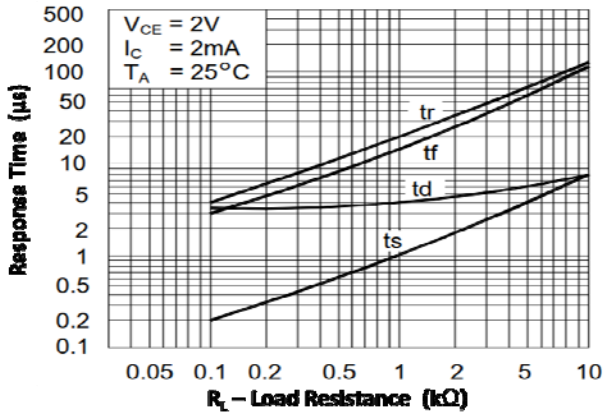
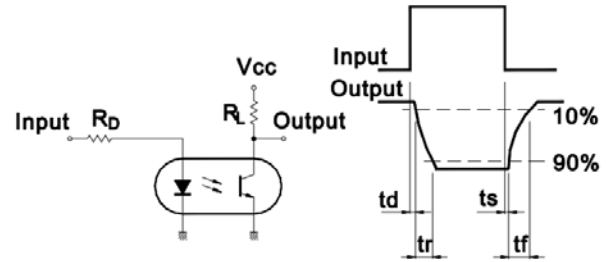

Fig 7 Response Time vs Load Resistance



Response Time Test Circuit

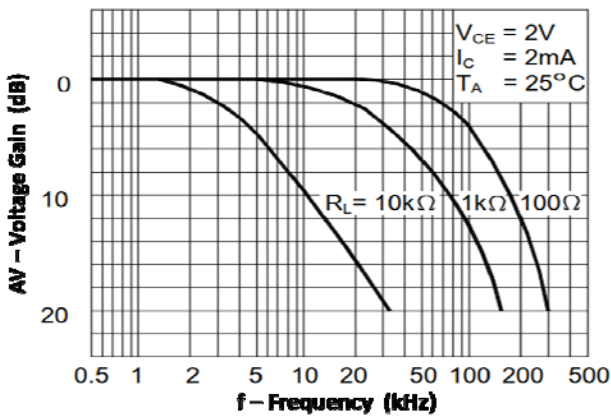

Fig 9 Frequency Response



Frequency Response Test Circuit



TLP521, TLP521-2, TLP521-4

ORDER INFORMATION

TLP521X, TLP521-1X (UL and VDE Approvals)			
After PN	PN	Description	Packing quantity
None	TLP521X, TLP521-1X TLP521XGR, TLP521-1XGR TLP521XBL, TLP521-1XBL, TLP521XGB, TLP521-1XGB	Standard DIP4	100 pcs per tube
G	TLP521XG, TLP521-1XG, TLP521XGRG, TLP521-1XGRG, TLP521XBLG, TLP521-1XBLG TLP521XGBG, TLP521-1XGBG	10mm Lead Spacing	100 pcs per tube
SM	TLP521XSM, TLP521-1XSM, TLP521XGRSM, TLP521-1XGRSM, TLP521XBLSM, TLP521-1XBLSM, TLP521XGBSM, TLP521-1XGBSM	Surface Mount	100 pcs per tube
SMT&R	TLP521XSMT&R, TLP521-1XSMT&R TLP521XGRSMT&R, TLP521-1XGRSMT&R, TLP521XBLSMT&R, TLP521-1XBLSMT&R, TLP521XGBSMT&R, TLP521-1XGBSMT&R	Surface Mount Tape & Reel	1000 pcs per reel

Note : Optional Order Part No. TLP521-1 for TLP521.



TLP521, TLP521-2, TLP521-4

ORDER INFORMATION

TLP521-2X (UL and VDE Approvals)			
After PN	PN	Description	Packing quantity
None	TLP521-2X, TLP521-2XGR, TLP521-2XBL, TLP521-2XGB	Standard DIP8	50 pcs per tube
G	TLP521-2XG, TLP521-2XGRG TLP521-2XB LG, TLP521-2XGBG	10mm Lead Spacing	50 pcs per tube
SM	TLP521-2XSM, TLP521-2XGRSM, TLP521-2XBLSM, TLP521-2XGBSM	Surface Mount	50 pcs per tube
SMT&R	TLP521-2XSMT&R, TLP521-2XGRSMT&R, TLP521-2XBLSMT&R, TLP521-2XGBSMT&R	Surface Mount Tape & Reel	1000 pcs per reel

TLP521-4X (UL and VDE Approvals)			
After PN	PN	Description	Packing quantity
None	TLP521-4X, TLP521-4XGR, TLP521-4XBL, TLP521-4XGB	Standard DIP16	25 pcs per tube
G	TLP521-4XG, TLP521-4XGRG, TLP521-4XB LG, TLP521-4XGBG	10mm Lead Spacing	25 pcs per tube
SM	TLP521-4XSM, TLP521-4XGRSM, TLP521-4XBLSM, TLP521-4XGBSM	Surface Mount	25 pcs per tube



TLP521, TLP521-2, TLP521-4

PACKAGE DIMENSIONS in mm (inch)

DIP

TLP521

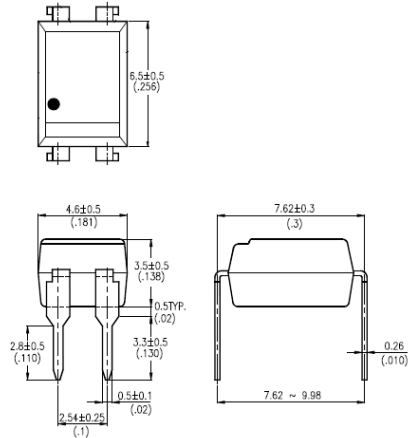

TLP521-2

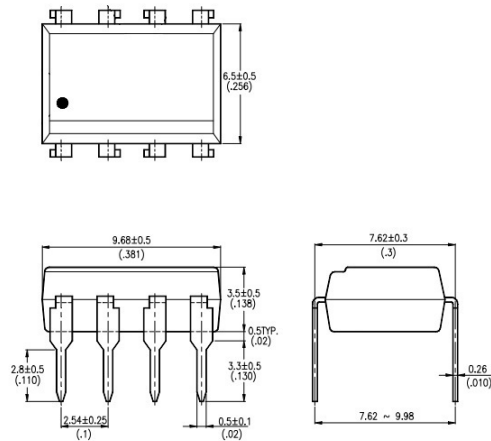

TLP521-4

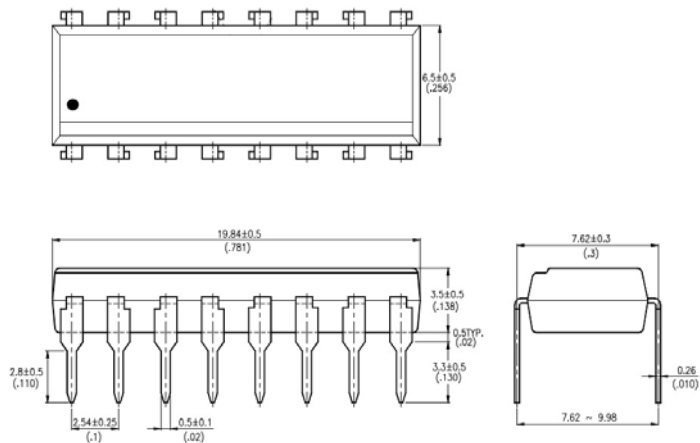



TLP521, TLP521-2, TLP521-4

PACKAGE DIMENSIONS in mm (inch)

G Form

TLP521G



TLP521-2G

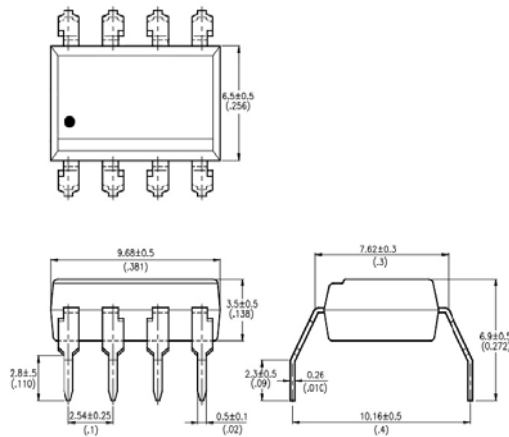

TLP521-4G





TLP521, TLP521-2, TLP521-4

PACKAGE DIMENSIONS in mm (inch)

SMD

TLP521SM



TLP521-2SM



TLP521-4SM

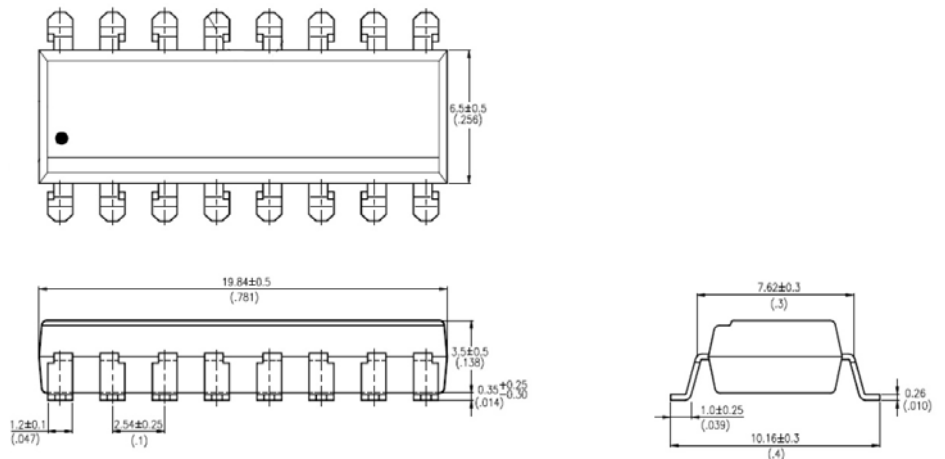



TLP521, TLP521-2, TLP521-4

RECOMMENDED PAD LAYOUT FOR SMD (mm)

TLP521SM



TLP521-2SM



TLP521-4SM





TLP521, TLP521-2, TLP521-4

TAPE AND REEL PACKAGING



TLP521SMT&R



TLP521-2SMT&R

Description	Symbol	Dimensions in mm (inches)
Tape wide	W	16 ± 0.3 (.63)
Pitch of sprocket holes	P_0	4 ± 0.1 (.15)
Distance of compartment	F	7.5 ± 0.1 (.295)
Distance of compartment to compartment	P_1	2 ± 0.1 (.079)
Distance of compartment to compartment	P_1	12 ± 0.1 (.472)



TLP521, TLP521-2, TLP521-4

**IR REFLOW SOLDERING TEMPERATURE PROFILE FOR SMD
(One Time Reflow Soldering is Recommended)**



Profile Details	Conditions
Preheat - Min Temperature (T_{SMIN}) - Max Temperature (T_{SMAX}) - Time T_{SMIN} to T_{SMAX} (t_s)	150°C 200°C 60s - 120s
Soldering Zone - Peak Temperature (T_P) - Time at Peak Temperature - Liquidous Temperature (T_L) - Time within 5°C of Actual Peak Temperature ($T_P - 5^\circ C$) - Time maintained above T_L (t_L) - Ramp Up Rate (T_L to T_P) - Ramp Down Rate (T_P to T_L)	260°C 10s max 217°C 30s max 60s - 100s 3°C/s max 6°C/s max
Average Ramp Up Rate (T_{smax} to T_P)	3°C/s max
Time 25°C to Peak Temperature	8 minutes max

Looking for pricing, stock, or lifecycle information?

Click below to explore more details on WIN SOURCE:

- [View TLP521-1\(GB,F\) on WIN SOURCE](#)
- [Toshiba Semiconductor and Storage Information](#)

Optimize Your Supply Chain with WIN SOURCE Solutions

- ✓ Global Sourcing Solution
- ✓ Obsolete Management
- ✓ Cost Control Management
- ✓ Shortage Management
- ✓ Alternative Solution
- ✓ Excess Inventory Management