



**THE DATASHEET OF  
SN74HC595N**



# SNx4HC595 8-Bit Shift Registers With 3-State Output Registers

## 1 Features

- 8-bit serial-in, parallel-out shift
- Wide operating voltage range of 2 V to 6 V
- High-current 3-state outputs can drive up to 15 LSTTL loads
- Low power consumption: 80- $\mu$ A (maximum)  $I_{CC}$
- $t_{pd} = 13$  ns (typical)
- $\pm 6$ -mA output drive at 5 V
- Low input current: 1  $\mu$ A (maximum)
- Shift register has direct clear
- On products compliant to MIL-PRF-38535, all parameters are tested unless otherwise noted. On all other products, production processing does not necessarily include testing of all parameters.

## 2 Applications

- Network switches
- Power infrastructure
- LED displays
- Servers

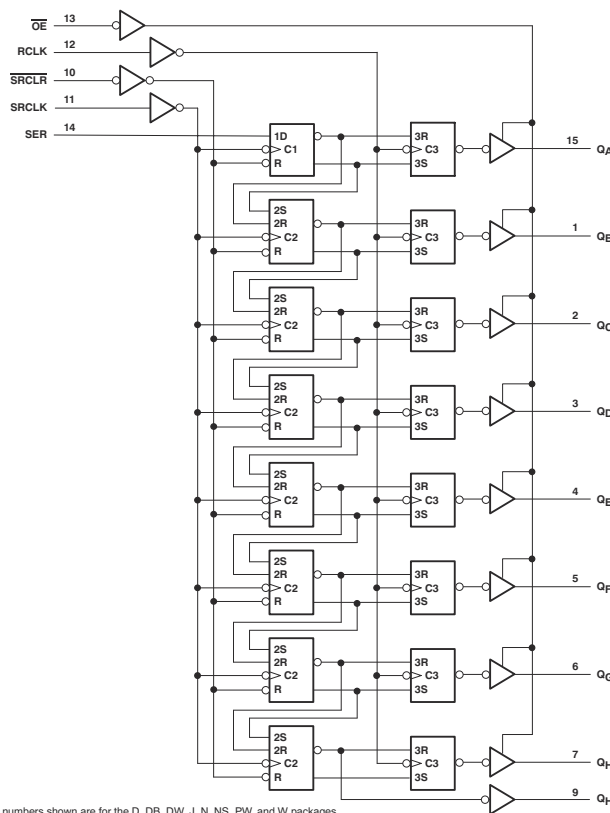
## 3 Description

The SNx4HC595 devices contain an 8-bit, serial-in, parallel-out shift register that feeds an 8-bit D-type storage register. The storage register has parallel 3-state outputs. Separate clocks are provided for both the shift and storage register. The shift register has a direct overriding clear (SRCLR) input, serial (SER) input, and serial outputs for cascading. When the output-enable ( $\overline{OE}$ ) input is high, the outputs are in the high-impedance state.

### Device Information

PART NUMBER	PACKAGE <sup>(1)</sup>	BODY SIZE (NOM)
SN54HC595FK	LCCC (20)	8.89 mm × 8.89 mm
SN54HC595J	CDIP (16)	21.34 mm × 6.92 mm
SN74HC595N	PDIP (16)	19.31 mm × 6.35 mm
SN74HC595D	SOIC (16)	9.90 mm × 3.90 mm
SN74HC595DW	SOIC (16)	10.30 mm × 7.50 mm
SN74HC595DB	SSOP (16)	6.20 mm × 5.30 mm
SN74HC595PW	TSSOP (16)	5.00 mm × 4.40 mm

(1) For all available packages, see the orderable addendum at the end of the data sheet.



Functional Block Diagram



## Table of Contents

<b>1 Features</b> .....	1	8.2 Functional Block Diagram.....	11
<b>2 Applications</b> .....	1	8.3 Feature Description.....	12
<b>3 Description</b> .....	1	8.4 Device Functional Modes.....	12
<b>4 Revision History</b> .....	2	<b>9 Application and Implementation</b> .....	13
<b>5 Pin Configuration and Functions</b> .....	3	9.1 Application Information.....	13
<b>6 Specifications</b> .....	4	9.2 Typical Application.....	13
6.1 Absolute Maximum Ratings.....	4	<b>10 Power Supply Recommendations</b> .....	15
6.2 ESD Ratings.....	4	<b>11 Layout</b> .....	15
6.3 Recommended Operating Conditions.....	4	11.1 Layout Guidelines.....	15
6.4 Thermal Information.....	5	11.2 Layout Example.....	15
6.5 Electrical Characteristics.....	5	<b>12 Device and Documentation Support</b> .....	16
6.6 Timing Requirements.....	6	12.1 Documentation Support.....	16
6.7 Switching Characteristics.....	8	12.2 Support Resources.....	16
6.8 Operating Characteristics.....	8	12.3 Trademarks.....	16
6.9 Typical Characteristics.....	9	12.4 Electrostatic Discharge Caution.....	16
<b>7 Parameter Measurement Information</b> .....	10	12.5 Glossary.....	16
<b>8 Detailed Description</b> .....	11	<b>13 Mechanical, Packaging, and Orderable Information</b> .....	16
8.1 Overview.....	11		

## 4 Revision History

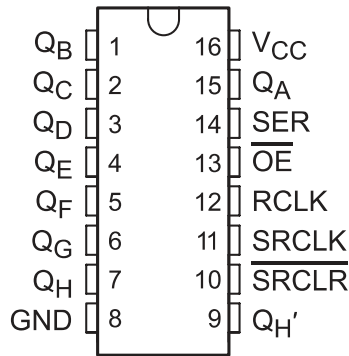
NOTE: Page numbers for previous revisions may differ from page numbers in the current version.

<b>Changes from Revision H (November 2009) to Revision I (August 2015)</b>	<b>Page</b>
• Added <i>Applications</i> section, <i>Device Information</i> table, <i>Pin Configuration and Functions</i> section, <i>ESD Ratings</i> table, <i>Thermal Information</i> table, <i>Feature Description</i> section, <i>Device Functional Modes</i> , <i>Application and Implementation</i> section, <i>Power Supply Recommendations</i> section, <i>Layout</i> section, <i>Device and Documentation Support</i> section, and <i>Mechanical, Packaging, and Orderable Information</i> section .....	1
• Deleted <i>Ordering Information</i> table. ....	1
• Added Military Disclaimer to <i>Features</i> list.....	1

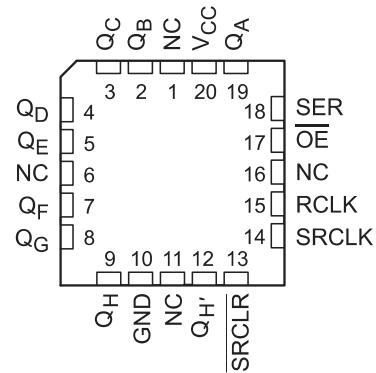
---

<b>Changes from Revision I (August 2015) to Revision J (October 2021)</b>	<b>Page</b>
• Updated the device information table, ESD ratings table, and the device functional modes table to fit modern data sheet standards.....	1

## 5 Pin Configuration and Functions



**D, N, NS, J, DB, or PW Package**  
**16-Pin SOIC, PDIP, SO, CDIP, SSOP, or TSSOP**  
**Top View**



**FK Package**  
**20-Pin LCCC**  
**Top View**

**Table 5-1. Pin Functions**

NAME	PIN		I/O <sup>(1)</sup>	DESCRIPTION
	SOIC, PDIP, SO, CDIP, SSOP, or TSSOP	LCCC		
GND	8	10	—	Ground Pin
$\overline{OE}$	13	17	I	Output Enable
Q <sub>A</sub>	15	19	O	Q <sub>A</sub> Output
Q <sub>B</sub>	1	2	O	Q <sub>B</sub> Output
Q <sub>C</sub>	2	3	O	Q <sub>C</sub> Output
Q <sub>D</sub>	3	4	O	Q <sub>D</sub> Output
Q <sub>E</sub>	4	5	O	Q <sub>E</sub> Output
Q <sub>F</sub>	5	7	O	Q <sub>F</sub> Output
Q <sub>G</sub>	6	8	O	Q <sub>G</sub> Output
Q <sub>H</sub>	7	9	O	Q <sub>H</sub> Output
Q <sub>H'</sub>	9	12	O	Q <sub>H'</sub> Output
RCLK	12	14	I	RCLK Input
SER	14	18	I	SER Input
SRCLK	11	14	I	SRCLK Input
$\overline{SRCLR}$	10	13	I	$\overline{SRCLR}$ Input
NC	—	1	—	No Connection
		16		
		11		
		16		
V <sub>CC</sub>	—	20	—	Power Pin

(1) Signal Types: I = Input, O = Output, I/O = Input or Output.

## 6 Specifications

### 6.1 Absolute Maximum Ratings

over operating free-air temperature range (unless otherwise noted)<sup>(1)</sup>

		MIN	MAX	UNIT
V <sub>CC</sub>	Supply voltage	-0.5	7	V
I <sub>IK</sub>	Input clamp current <sup>(2)</sup>	V <sub>I</sub> < 0 or V <sub>I</sub> > V <sub>CC</sub>		±20 mA
I <sub>OK</sub>	Output clamp current <sup>(2)</sup>	V <sub>O</sub> < 0 or V <sub>O</sub> > V <sub>CC</sub>		±20 mA
I <sub>O</sub>	Continuous output current	V <sub>O</sub> = 0 to V <sub>CC</sub>		±35 mA
	Continuous current through V <sub>CC</sub> or GND			±70 mA
T <sub>J</sub>	Junction temperature			150 °C
T <sub>stg</sub>	Storage temperature	-65	150	°C

- (1) Stresses beyond those listed under *Absolute Maximum Ratings* may cause permanent damage to the device. These are stress ratings only, and functional operation of the device at these or any other conditions beyond those indicated under *Recommended Operating Conditions* is not implied. Exposure to absolute-maximum-rated conditions for extended periods may affect device reliability.
- (2) The input and output voltage ratings may be exceeded if the input and output current ratings are observed.

### 6.2 ESD Ratings

		VALUE	UNIT
V <sub>(ESD)</sub>	Electrostatic discharge	Human body model (HBM), per ANSI/ESDA/JEDEC JS-001 <sup>(1)</sup>	2000
		Charged device model (CDM), per ANSI/ESDA/JEDEC JS-002 <sup>(2)</sup>	1000

- (1) JEDEC document JEP155 states that 500-V HBM allows safe manufacturing with a standard ESD control process.
- (2) JEDEC document JEP157 states that 250-V CDM allows safe manufacturing with a standard ESD control process.

### 6.3 Recommended Operating Conditions

over operating free-air temperature range (unless otherwise noted)<sup>(1)</sup>

		SN54HC595			SN74HC595			UNIT
		MIN	NOM	MAX	MIN	NOM	MAX	
V <sub>CC</sub>	Supply voltage	2	5	6	2	5	6	V
V <sub>IH</sub>	High-level input voltage	V <sub>CC</sub> = 2 V		1.5	1.5			V
		V <sub>CC</sub> = 4.5 V		3.15	3.15			
		V <sub>CC</sub> = 6 V		4.2	4.2			
V <sub>IL</sub>	Low-level input voltage	V <sub>CC</sub> = 2 V			0.5		0.5	V
		V <sub>CC</sub> = 4.5 V			1.35		1.35	
		V <sub>CC</sub> = 6 V			1.8		1.8	
V <sub>I</sub>	Input voltage	0		V <sub>CC</sub>	0		V <sub>CC</sub>	V
V <sub>O</sub>	Output voltage	0		V <sub>CC</sub>	0		V <sub>CC</sub>	V
Δt/Δv	Input transition rise or fall time <sup>(2)</sup>	V <sub>CC</sub> = 2 V			1000		1000	ns
		V <sub>CC</sub> = 4.5 V			500		500	
		V <sub>CC</sub> = 6 V			400		400	
T <sub>A</sub>	Operating free-air temperature	-55		125	-40		85	°C

- (1) All unused inputs of the device must be held at V<sub>CC</sub> or GND to ensure proper device operation. See the TI application report, *Implications of Slow or Floating CMOS Inputs*, SCBA004.
- (2) If this device is used in the threshold region (from V<sub>IL</sub> max = 0.5 V to V<sub>IH</sub> min = 1.5 V), there is a potential to go into the wrong state from induced grounding, causing double clocking. Operating with the inputs at t<sub>i</sub> = 1000 ns and V<sub>CC</sub> = 2 V does not damage the device; however, functionally, the CLK inputs are not ensured while in the shift, count, or toggle operating modes.

## 6.4 Thermal Information

THERMAL METRIC <sup>(1)</sup>	SN74HC595						UNIT
	D (SOIC)	DB (SSOP)	DW (SOIC)	N (PDIP)	NS (SO)	PW (TSSOP)	
	16 PINS	16 PINS	16 PINS	16 PINS	16 PINS	16 PINS	
R <sub>θJA</sub> Junction-to-ambient thermal resistance	73	82	57	67	64	108	°C/W

(1) For more information about traditional and new thermal metrics, see the *Semiconductor and IC Package Thermal Metrics* application report, [SPRA953](#).

## 6.5 Electrical Characteristics

over recommended operating free-air temperature range (unless otherwise noted)

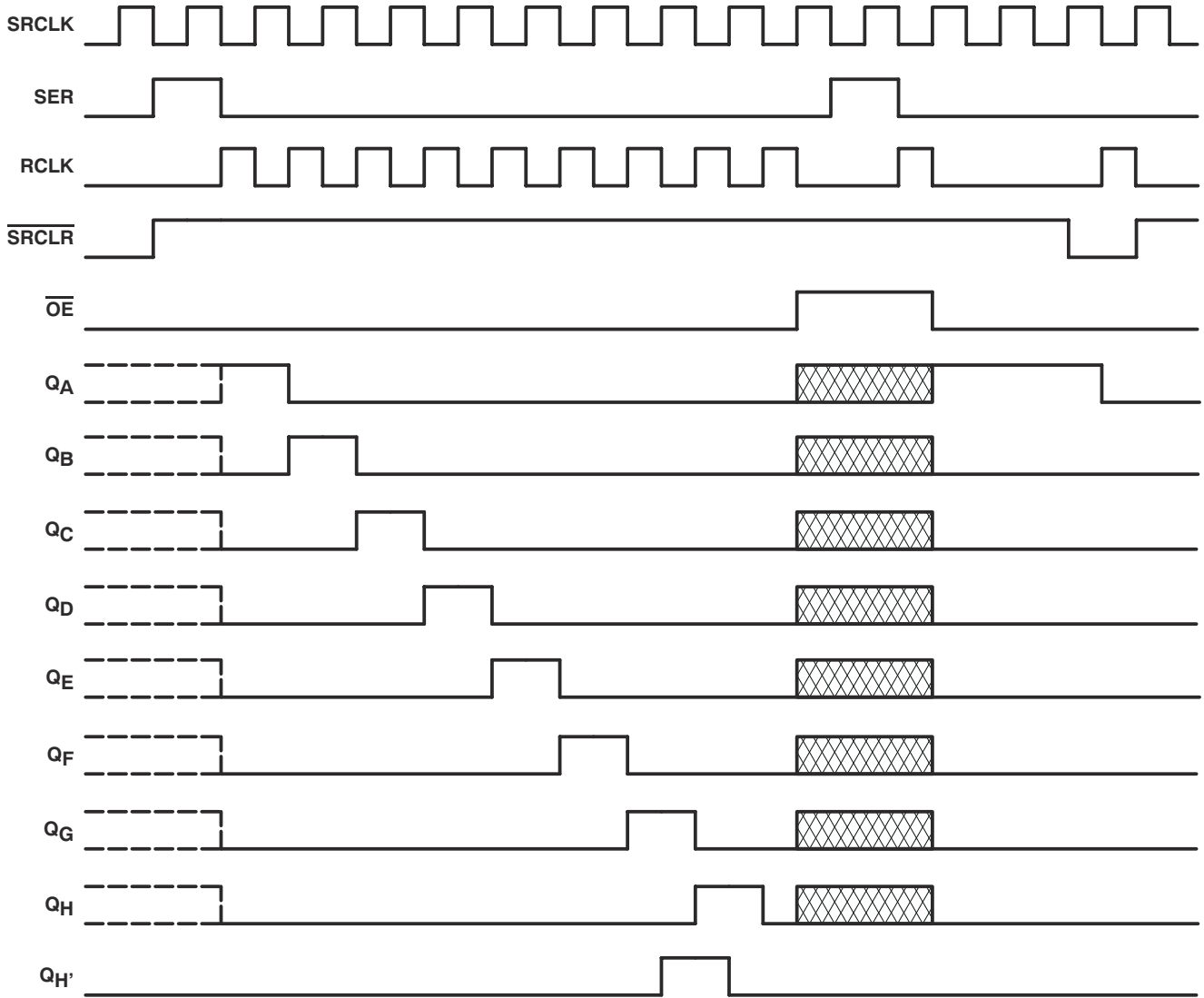
PARAMETER	TEST CONDITIONS		V <sub>CC</sub>	T <sub>A</sub> = 25°C			SN54HC595		SN74HC595		UNIT
				MIN	TYP	MAX	MIN	MAX	MIN	MAX	
V <sub>OH</sub>	V <sub>I</sub> = V <sub>IH</sub> or V <sub>IL</sub>	I <sub>OH</sub> = -20 μA	2 V	1.9	1.998		1.9		1.9	V	
			4.5 V	4.4	4.499		4.4		4.4		
			6 V	5.9	5.999		5.9		5.9		
		4.5 V	Q <sub>H</sub> , I <sub>OH</sub> = -4 mA	3.98	4.3		3.7		3.84		
			Q <sub>A</sub> - Q <sub>H</sub> , I <sub>OH</sub> = -6 mA	3.98	4.3		3.7		3.84		
			Q <sub>H</sub> , I <sub>OH</sub> = -5.2 mA	5.48	5.8		5.2		5.34		
6 V	Q <sub>A</sub> - Q <sub>H</sub> , I <sub>OH</sub> = -7.8 mA	5.48	5.8		5.2		5.34				
V <sub>OL</sub>	V <sub>I</sub> = V <sub>IH</sub> or V <sub>IL</sub>	I <sub>OL</sub> = 20 μA	2 V		0.002	0.1		0.1	0.1	V	
			4.5 V		0.001	0.1		0.1	0.1		
			6 V		0.001	0.1		0.1	0.1		
		4.5 V	Q <sub>H</sub> , I <sub>OL</sub> = 4 mA		0.17	0.26		0.4	0.33		
			Q <sub>A</sub> - Q <sub>H</sub> , I <sub>OL</sub> = 6 mA		0.17	0.26		0.4	0.33		
			Q <sub>H</sub> , I <sub>OL</sub> = 5.2 mA		0.15	0.26		0.4	0.33		
6 V	Q <sub>A</sub> - Q <sub>H</sub> , I <sub>OL</sub> = 7.8 mA		0.15	0.26		0.4	0.33				
I <sub>I</sub>	V <sub>I</sub> = V <sub>CC</sub> or 0	6 V		±0.1	±100		±1000	±1000	nA		
I <sub>OZ</sub>	V <sub>O</sub> = V <sub>CC</sub> or 0, Q <sub>A</sub> - Q <sub>H</sub>	6 V		±0.01	±0.5		±10	±5	μA		
I <sub>CC</sub>	V <sub>I</sub> = V <sub>CC</sub> or 0, I <sub>O</sub> = 0	6 V			8		160	80	μA		
C <sub>i</sub>		2 V to 6 V		3	10		10	10	pF		


## 6.6 Timing Requirements

over operating free-air temperature range (unless otherwise noted)

		V <sub>CC</sub>	T <sub>A</sub> = 25°C		SN54HC595		SN74HC595		UNIT
			MIN	MAX	MIN	MAX	MIN	MAX	
f <sub>clock</sub>	Clock frequency	2 V	6		4.2		5		MHz
		4.5 V	31		21		25		
		6 V	36		25		29		
t <sub>w</sub>	SRCLK or RCLK high or low	2 V	80		120		100	ns	
		4.5 V	16		24		20		
		6 V	14		20		17		
	SRCLR low	2 V	80		120		100		
		4.5 V	16		24		20		
		6 V	14		20		17		
t <sub>su</sub>	SER before SRCLK↑	2 V	100		150		125	ns	
		4.5 V	20		30		25		
		6 V	17		25		21		
	SRCLK↑ before RCLK↑ <sup>(1)</sup>	2 V	75		113		94		
		4.5 V	15		23		19		
		6 V	13		19		16		
	SRCLR low before RCLK↑	2 V	50		75		65		
		4.5 V	10		15		13		
		6 V	9		13		11		
	SRCLR high (inactive) before SRCLK↑	2 V	50		75		60		
		4.5 V	10		15		12		
		6 V	9		13		11		
t <sub>h</sub>	Hold time, SER after SRCLK↑	2 V	0		0		0	ns	
		4.5 V	0		0		0		
		6 V	0		0		0		

(1) This set-up time allows the storage register to receive stable data from the shift register. The clocks can be tied together, in which case the shift register is one clock pulse ahead of the storage register.



NOTE:  implies that the output is in 3-State mode.

**Figure 6-1. Timing Diagram**

## 6.7 Switching Characteristics

Over recommended operating free-air temperature range.

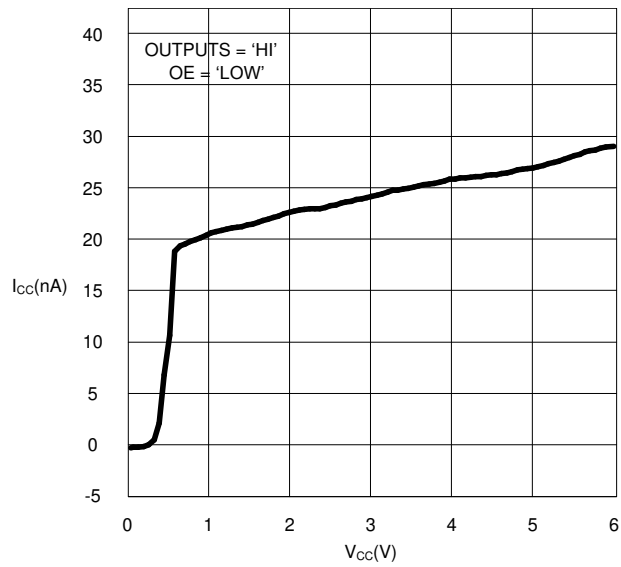
PARAMETER	FROM (INPUT)	TO (OUTPUT)	LOAD CAPACITANCE	V <sub>CC</sub>	T <sub>A</sub> = 25°C			SN54HC595		SN74HC595		UNIT
					MIN	TYP	MAX	MIN	MAX	MIN	MAX	
f <sub>max</sub>			50 pF	2 V	6	26		4.2	5	MHz		
				4.5 V	31	38		21	25			
				6 V	36	42		25	29			
t <sub>pd</sub>	SRCLK	Q <sub>H'</sub>	50 pF	2 V		50	160	240	200	ns		
				4.5 V		17	32	48	40			
				6 V		14	27	41	34			
	RCLK	Q <sub>A</sub> – Q <sub>H</sub>	50 pF	2 V		50	150	225	187			
				4.5 V		17	30	45	37			
				6 V		14	26	38	32			
t <sub>PHL</sub>	$\overline{\text{SRCLR}}$	Q <sub>H'</sub>	50 pF	2 V		51	175	261	219	ns		
				4.5 V		18	35	52	44			
				6 V		15	30	44	37			
t <sub>en</sub>	$\overline{\text{OE}}$	Q <sub>A</sub> – Q <sub>H</sub>	50 pF	2 V		40	150	255	187	ns		
				4.5 V		15	30	45	37			
				6 V		13	26	38	32			
t <sub>dis</sub>	$\overline{\text{OE}}$	Q <sub>A</sub> – Q <sub>H</sub>	50 pF	2 V		42	200	300	250	ns		
				4.5 V		23	40	60	50			
				6 V		20	34	51	43			
t <sub>t</sub>		Q <sub>A</sub> – Q <sub>H</sub>	50 pF	2 V		28	60	90	75	ns		
				4.5 V		8	12	18	15			
				6 V		6	10	15	13			
		Q <sub>H'</sub>	50 pF	2 V		28	75	110	95			
				4.5 V		8	15	22	19			
				6 V		6	13	19	16			
t <sub>pd</sub>	RCLK	Q <sub>A</sub> – Q <sub>H</sub>	150 pf	2 V		60	200	300	250	ns		
				4.5 V		22	40	60	50			
				6 V		19	34	51	43			
t <sub>en</sub>	$\overline{\text{OE}}$	Q <sub>A</sub> – Q <sub>H</sub>	150 pf	2 V		70	200	298	250	ns		
				4.5 V		23	40	60	50			
				6 V		19	34	51	43			
t <sub>t</sub>		Q <sub>A</sub> – Q <sub>H</sub>	150 pf	2 V		45	210	315	265	ns		
				4.5 V		17	42	63	53			
				6 V		13	36	53	45			

## 6.8 Operating Characteristics

T<sub>A</sub> = 25°C

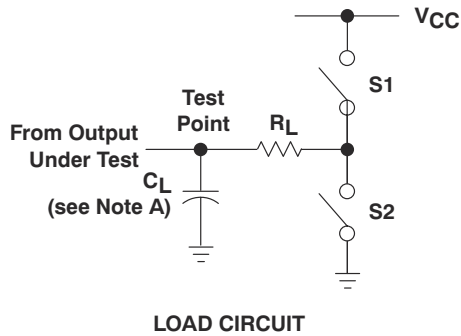
PARAMETER	TEST CONDITIONS	TYP	UNIT
C <sub>pd</sub> Power dissipation capacitance	No load	400	pF

## 6.9 Typical Characteristics

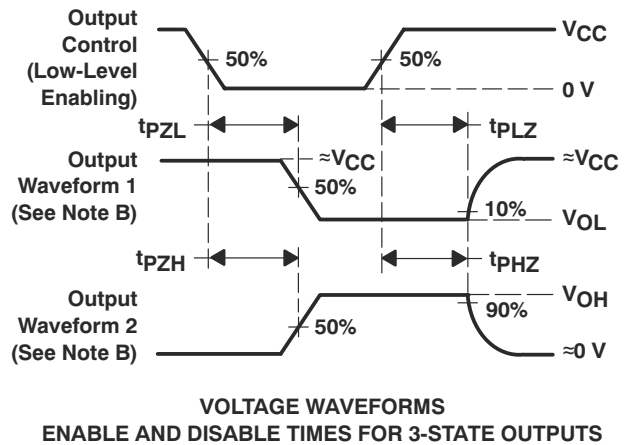
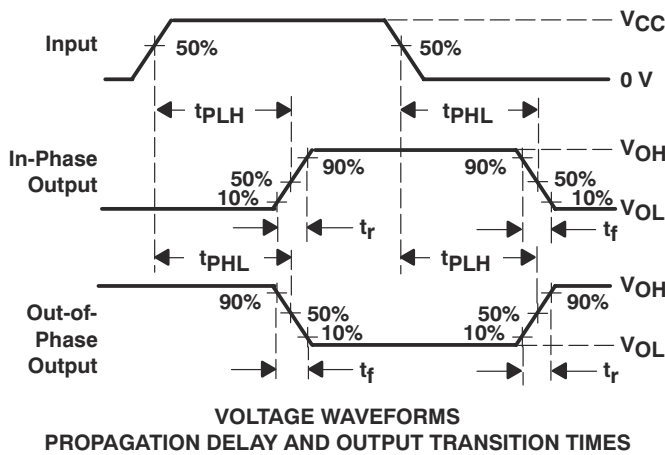
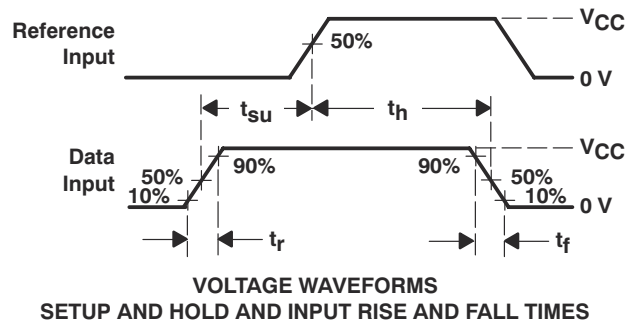
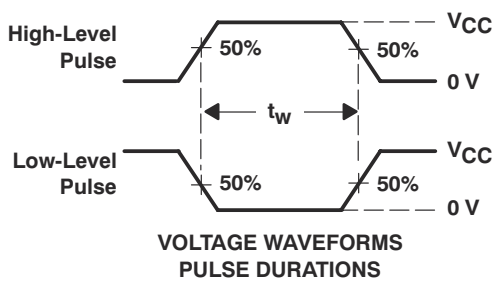


**Figure 6-2. SN74HC595 I<sub>CC</sub> vs. V<sub>CC</sub>**

## 7 Parameter Measurement Information



PARAMETER	$R_L$	$C_L$	S1	S2
$t_{en}$	1 k $\Omega$	50 pF or 150 pF	Open	Closed
			Closed	Open
$t_{dis}$	1 k $\Omega$	50 pF	Open	Closed
			Closed	Open
$t_{pd}$ or $t_t$		50 pF or 150 pF	Open	Open



- NOTES: A.  $C_L$  includes probe and test-fixture capacitance.  
 B. Waveform 1 is for an output with internal conditions such that the output is low, except when disabled by the output control. Waveform 2 is for an output with internal conditions such that the output is high, except when disabled by the output control.  
 C. Phase relationships between waveforms were chosen arbitrarily. All input pulses are supplied by generators having the following characteristics:  $PRR \leq 1$  MHz,  $Z_O = 50 \Omega$ ,  $t_r = 6$  ns,  $t_f = 6$  ns.  
 D. For clock inputs,  $f_{max}$  is measured when the input duty cycle is 50%.  
 E. The outputs are measured one at a time, with one input transition per measurement.  
 F.  $t_{PLZ}$  and  $t_{PHZ}$  are the same as  $t_{dis}$ .  
 G.  $t_{PZL}$  and  $t_{PZH}$  are the same as  $t_{en}$ .  
 H.  $t_{PLH}$  and  $t_{PHL}$  are the same as  $t_{pd}$ .

**Figure 7-1. Load Circuit and Voltage Waveforms**

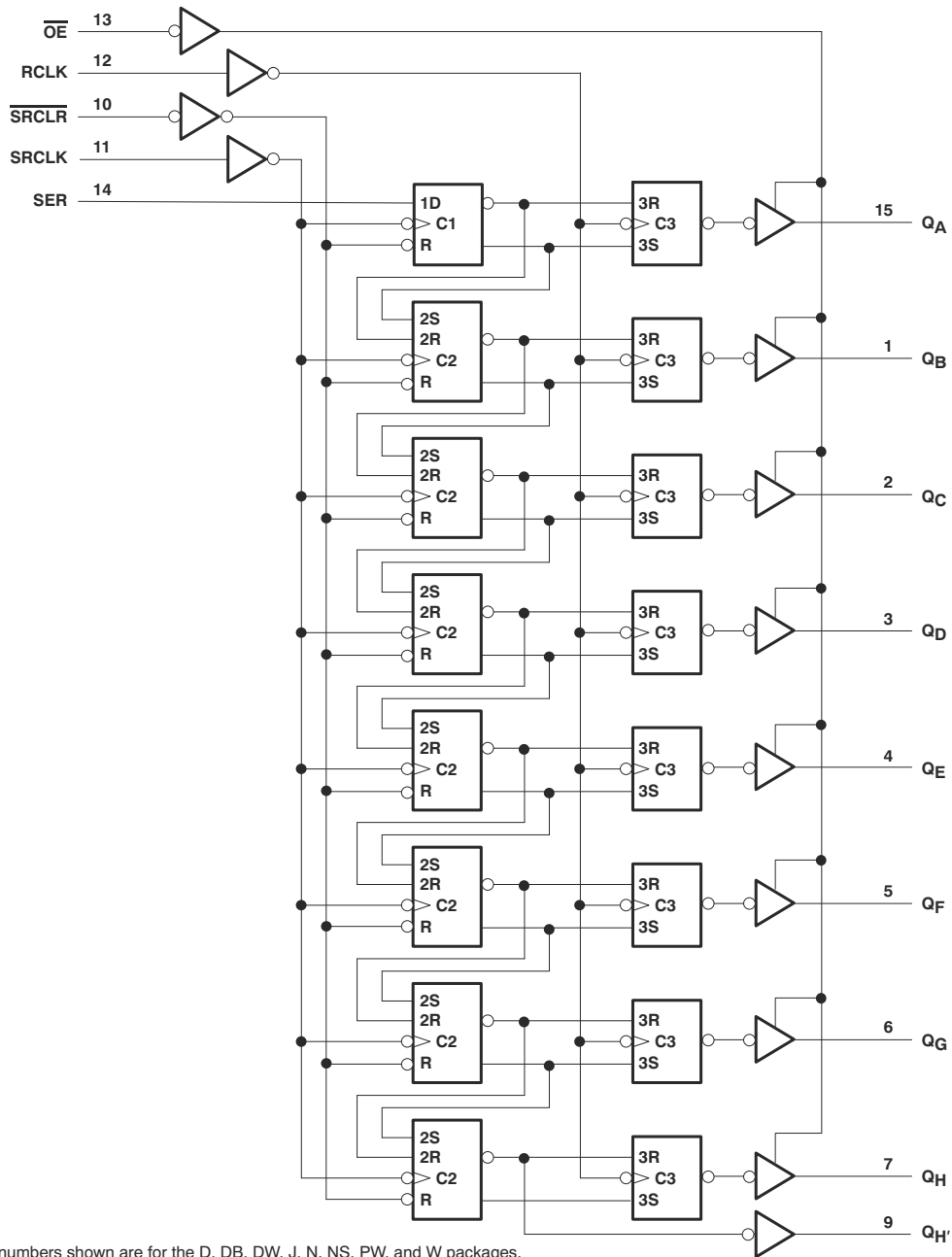
## 8 Detailed Description

### 8.1 Overview

The SNx4HC595 is part of the HC family of logic devices intended for CMOS applications. The SNx4HC595 is an 8-bit shift register that feeds an 8-bit D-type storage register.

Both the shift register clock (SRCLK) and storage register clock (RCLK) are positive-edge triggered. If both clocks are connected together, the shift register always is one clock pulse ahead of the storage register.

### 8.2 Functional Block Diagram



### 8.3 Feature Description

The SNx4HC595 devices are 8-bit Serial-In, Parallel-Out Shift Registers. They have a wide operating current of 2 V to 6 V, and the high-current 3-state outputs can drive up to 15 LSTTL Loads. The devices have a low power consumption of 80- $\mu$ A (Maximum)  $I_{CC}$ . Additionally, the devices have a low input current of 1  $\mu$ A (Maximum) and a  $\pm 6$ -mA Output Drive at 5 V.

### 8.4 Device Functional Modes

Table 8-1 lists the functional modes of the SNx4HC595 devices.

**Table 8-1. Function Table**

INPUTS					FUNCTION
SER	SRCLK	SRCLR	RCLK	$\overline{OE}$	
X	X	X	X	H	Outputs $Q_A - Q_H$ are disabled.
X	X	X	X	L	Outputs $Q_A - Q_H$ are enabled.
X	X	L	X	X	Shift register is cleared.
L	$\uparrow$	H	X	X	First stage of the shift register goes low. Other stages store the data of previous stage, respectively.
H	$\uparrow$	H	X	X	First stage of the shift register goes high. Other stages store the data of previous stage, respectively.
X	X	X	$\uparrow$	X	Shift-register data is stored in the storage register.

## 9 Application and Implementation

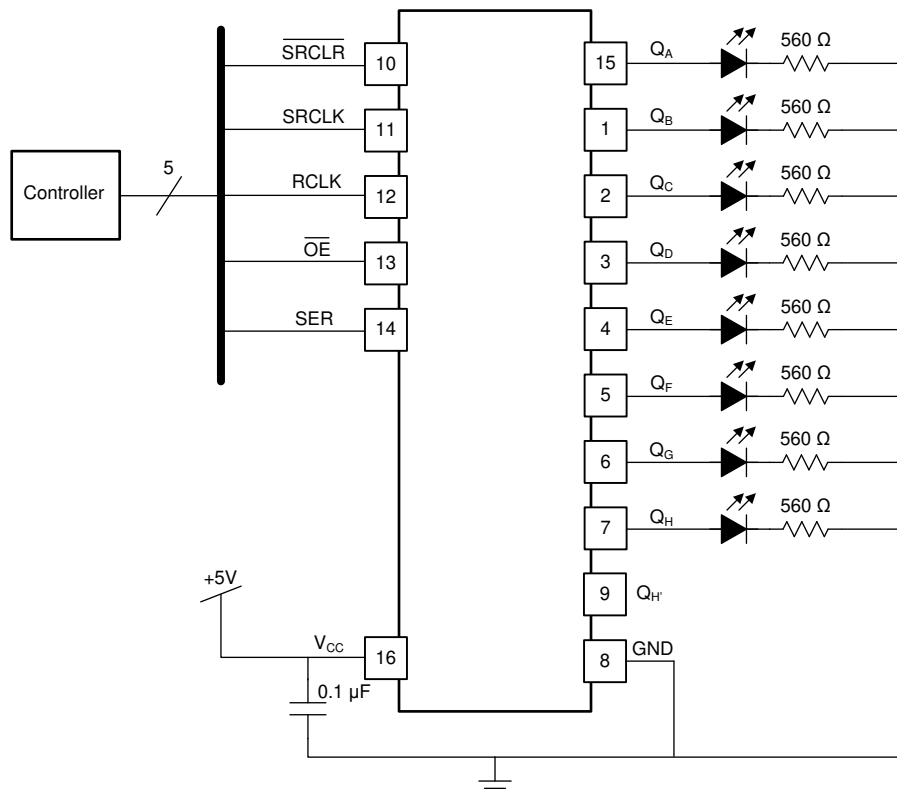
### Note

Information in the following applications sections is not part of the TI component specification, and TI does not warrant its accuracy or completeness. TI's customers are responsible for determining suitability of components for their purposes, as well as validating and testing their design implementation to confirm system functionality.

### 9.1 Application Information

The SNx4HC595 is a low-drive CMOS device that can be used for a multitude of bus interface type applications where output ringing is a concern. The low drive and slow edge rates will minimize overshoot and undershoot on the outputs.

### 9.2 Typical Application



**Figure 9-1. Typical Application Schematic**

#### 9.2.1 Design Requirements

This device uses CMOS technology and has balanced output drive. Take care to avoid bus contention because it can drive currents that would exceed maximum limits. The high drive will also create fast edges into light loads so routing and load conditions should be considered to prevent ringing.

## 9.2.2 Detailed Design Procedure

- Recommended input conditions
  - Specified high and low levels. See ( $V_{IH}$  and  $V_{IL}$ ) in [Section 6.3](#) table.
  - Specified high and low levels. See ( $V_{IH}$  and  $V_{IL}$ ) in [Section 6.3](#) table.
  - Inputs are overvoltage tolerant allowing them to go as high as 5.5 V at any valid  $V_{CC}$
- Recommend output conditions
  - Load currents should not exceed 35 mA per output and 70 mA total for the part
  - Outputs should not be pulled above  $V_{CC}$

## 9.2.3 Application Curves

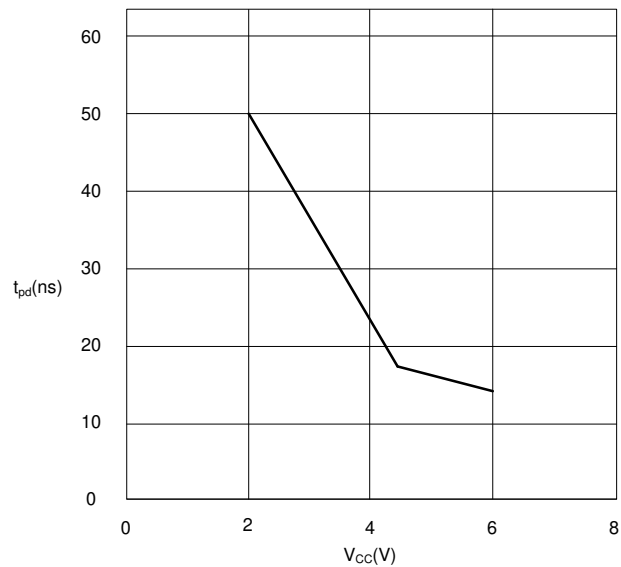


Figure 9-2. SN75HC595  $t_{pd}$  vs.  $V_{CC}$

## 10 Power Supply Recommendations

The power supply can be any voltage between the minimum and maximum supply voltage rating located in [Section 6.3](#) table.

Each  $V_{CC}$  pin should have a good bypass capacitor to prevent power disturbance. For devices with a single supply, 0.1  $\mu\text{f}$  is recommended; if there are multiple  $V_{CC}$  pins, then 0.01  $\mu\text{f}$  or 0.022  $\mu\text{f}$  is recommended for each power pin. It is acceptable to parallel multiple bypass caps to reject different frequencies of noise. A 0.1  $\mu\text{f}$  and a 1  $\mu\text{f}$  are commonly used in parallel. The bypass capacitor should be installed as close to the power pin as possible for best results.

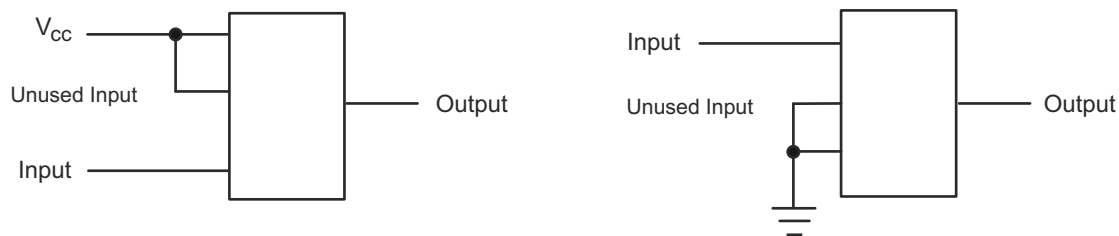
## 11 Layout

### 11.1 Layout Guidelines

When using multiple-bit logic devices, inputs should never float.

In many cases, functions or parts of functions of digital logic devices are unused, for example, when only two inputs of a triple-input AND gate are used or only 3 of the 4 buffer gates are used. Such input pins should not be left unconnected because the undefined voltages at the outside connections result in undefined operational states. [Figure 11-1](#) specifies the rules that must be observed under all circumstances. All unused inputs of digital logic devices must be connected to a high or low bias to prevent them from floating. The logic level that should be applied to any particular unused input depends on the function of the device. Generally they will be tied to GND or  $V_{CC}$ , whichever makes more sense or is more convenient. It is generally acceptable to float outputs, unless the part is a transceiver. If the transceiver has an output enable pin, it will disable the output section of the part when asserted. This will not disable the input section of the I/Os, so they cannot float when disabled.

### 11.2 Layout Example



**Figure 11-1. Layout Diagram**

## 12 Device and Documentation Support

### 12.1 Documentation Support

#### 12.1.1 Related Documentation

For related documentation, see the following:

- Texas Instruments, [Implications of Slow or Floating CMOS Inputs application brief](#)

### 12.2 Support Resources

[TI E2E™ support forums](#) are an engineer's go-to source for fast, verified answers and design help — straight from the experts. Search existing answers or ask your own question to get the quick design help you need.

Linked content is provided "AS IS" by the respective contributors. They do not constitute TI specifications and do not necessarily reflect TI's views; see TI's [Terms of Use](#).

### 12.3 Trademarks

TI E2E™ is a trademark of Texas Instruments.

All trademarks are the property of their respective owners.

### 12.4 Electrostatic Discharge Caution



This integrated circuit can be damaged by ESD. Texas Instruments recommends that all integrated circuits be handled with appropriate precautions. Failure to observe proper handling and installation procedures can cause damage.

ESD damage can range from subtle performance degradation to complete device failure. Precision integrated circuits may be more susceptible to damage because very small parametric changes could cause the device not to meet its published specifications.

### 12.5 Glossary

[TI Glossary](#) This glossary lists and explains terms, acronyms, and definitions.

## 13 Mechanical, Packaging, and Orderable Information

The following pages include mechanical packaging and orderable information. This information is the most current data available for the designated devices. This data is subject to change without notice and revision of this document. For browser based versions of this data sheet, refer to the left hand navigation.

**PACKAGING INFORMATION**

Orderable Device	Status (1)	Package Type	Package Drawing	Pins	Package Qty	Eco Plan (2)	Lead finish/ Ball material (6)	MSL Peak Temp (3)	Op Temp (°C)	Device Marking (4/5)	Samples
5962-86816012A	ACTIVE	LCCC	FK	20	55	Non-RoHS & Green	SNPB	N / A for Pkg Type	-55 to 125	5962-86816012A SNJ54HC 595FK	<a href="#">Samples</a>
5962-8681601EA	ACTIVE	CDIP	J	16	25	Non-RoHS & Green	SNPB	N / A for Pkg Type	-55 to 125	5962-8681601EA SNJ54HC595J	<a href="#">Samples</a>
5962-8681601VEA	ACTIVE	CDIP	J	16	25	Non-RoHS & Green	SNPB	N / A for Pkg Type	-55 to 125	5962-8681601VE A SNV54HC595J	<a href="#">Samples</a>
5962-8681601VFA	ACTIVE	CFP	W	16	25	Non-RoHS & Green	SNPB	N / A for Pkg Type	-55 to 125	5962-8681601VF A SNV54HC595W	<a href="#">Samples</a>
SN54HC595J	ACTIVE	CDIP	J	16	25	Non-RoHS & Green	SNPB	N / A for Pkg Type	-55 to 125	SN54HC595J	<a href="#">Samples</a>
SN74HC595DBR	ACTIVE	SSOP	DB	16	2000	RoHS & Green	NIPDAU	Level-1-260C-UNLIM	-40 to 85	HC595	<a href="#">Samples</a>
SN74HC595DBRE4	ACTIVE	SSOP	DB	16	2000	RoHS & Green	NIPDAU	Level-1-260C-UNLIM	-40 to 85	HC595	<a href="#">Samples</a>
SN74HC595DBRG4	ACTIVE	SSOP	DB	16	2000	RoHS & Green	NIPDAU	Level-1-260C-UNLIM	-40 to 85	HC595	<a href="#">Samples</a>
SN74HC595DR	ACTIVE	SOIC	D	16	2500	RoHS & Green	NIPDAU   SN	Level-1-260C-UNLIM	-40 to 85	HC595	<a href="#">Samples</a>
SN74HC595DRE4	ACTIVE				2500	TBD	Call TI	Call TI	-40 to 85		<a href="#">Samples</a>
SN74HC595DRG3	ACTIVE	SOIC	D	16	2500	RoHS & Green	SN	Level-1-260C-UNLIM	-40 to 85	HC595	<a href="#">Samples</a>
SN74HC595DRG4	ACTIVE	SOIC	D	16	2500	RoHS & Green	NIPDAU	Level-1-260C-UNLIM	-40 to 85	HC595	<a href="#">Samples</a>
SN74HC595DWR	ACTIVE	SOIC	DW	16	2000	RoHS & Green	NIPDAU	Level-1-260C-UNLIM	-40 to 85	HC595	<a href="#">Samples</a>
SN74HC595N	ACTIVE	PDIP	N	16	25	RoHS & Green	NIPDAU	N / A for Pkg Type	-40 to 85	SN74HC595N	<a href="#">Samples</a>
SN74HC595NE4	ACTIVE	PDIP	N	16	25	RoHS & Green	NIPDAU	N / A for Pkg Type	-40 to 85	SN74HC595N	<a href="#">Samples</a>
SN74HC595NSR	ACTIVE	SO	NS	16	2000	RoHS & Green	NIPDAU	Level-1-260C-UNLIM	-40 to 85	HC595	<a href="#">Samples</a>
SN74HC595PWR	ACTIVE	TSSOP	PW	16	2000	RoHS & Green	NIPDAU   SN	Level-1-260C-UNLIM	-40 to 85	HC595	<a href="#">Samples</a>

Orderable Device	Status (1)	Package Type	Package Drawing	Pins	Package Qty	Eco Plan (2)	Lead finish/ Ball material (6)	MSL Peak Temp (3)	Op Temp (°C)	Device Marking (4/5)	Samples
SN74HC595PWRG4	ACTIVE	TSSOP	PW	16	2000	RoHS & Green	NIPDAU	Level-1-260C-UNLIM	-40 to 85	HC595	<a href="#">Samples</a>
SNJ54HC595FK	ACTIVE	LCCC	FK	20	55	Non-RoHS & Green	SNPB	N / A for Pkg Type	-55 to 125	5962-86816012A SNJ54HC595FK	<a href="#">Samples</a>
SNJ54HC595J	ACTIVE	CDIP	J	16	25	Non-RoHS & Green	SNPB	N / A for Pkg Type	-55 to 125	5962-8681601EA SNJ54HC595J	<a href="#">Samples</a>

(1) The marketing status values are defined as follows:

**ACTIVE:** Product device recommended for new designs.

**LIFEBUY:** TI has announced that the device will be discontinued, and a lifetime-buy period is in effect.

**NRND:** Not recommended for new designs. Device is in production to support existing customers, but TI does not recommend using this part in a new design.

**PREVIEW:** Device has been announced but is not in production. Samples may or may not be available.

**OBSOLETE:** TI has discontinued the production of the device.

(2) **RoHS:** TI defines "RoHS" to mean semiconductor products that are compliant with the current EU RoHS requirements for all 10 RoHS substances, including the requirement that RoHS substance do not exceed 0.1% by weight in homogeneous materials. Where designed to be soldered at high temperatures, "RoHS" products are suitable for use in specified lead-free processes. TI may reference these types of products as "Pb-Free".

**RoHS Exempt:** TI defines "RoHS Exempt" to mean products that contain lead but are compliant with EU RoHS pursuant to a specific EU RoHS exemption.

**Green:** TI defines "Green" to mean the content of Chlorine (Cl) and Bromine (Br) based flame retardants meet JS709B low halogen requirements of <=1000ppm threshold. Antimony trioxide based flame retardants must also meet the <=1000ppm threshold requirement.

(3) MSL, Peak Temp. - The Moisture Sensitivity Level rating according to the JEDEC industry standard classifications, and peak solder temperature.

(4) There may be additional marking, which relates to the logo, the lot trace code information, or the environmental category on the device.

(5) Multiple Device Markings will be inside parentheses. Only one Device Marking contained in parentheses and separated by a "~" will appear on a device. If a line is indented then it is a continuation of the previous line and the two combined represent the entire Device Marking for that device.

(6) Lead finish/Ball material - Orderable Devices may have multiple material finish options. Finish options are separated by a vertical ruled line. Lead finish/Ball material values may wrap to two lines if the finish value exceeds the maximum column width.

**Important Information and Disclaimer:**The information provided on this page represents TI's knowledge and belief as of the date that it is provided. TI bases its knowledge and belief on information provided by third parties, and makes no representation or warranty as to the accuracy of such information. Efforts are underway to better integrate information from third parties. TI has taken and continues to take reasonable steps to provide representative and accurate information but may not have conducted destructive testing or chemical analysis on incoming materials and chemicals. TI and TI suppliers consider certain information to be proprietary, and thus CAS numbers and other limited information may not be available for release.

In no event shall TI's liability arising out of such information exceed the total purchase price of the TI part(s) at issue in this document sold by TI to Customer on an annual basis.

**OTHER QUALIFIED VERSIONS OF SN54HC595, SN54HC595-SP, SN74HC595 :**

- Catalog : [SN74HC595](#), [SN54HC595](#)
- Enhanced Product : [SN74HC595-EP](#), [SN74HC595-EP](#)
- Military : [SN54HC595](#)
- Space : [SN54HC595-SP](#)

NOTE: Qualified Version Definitions:

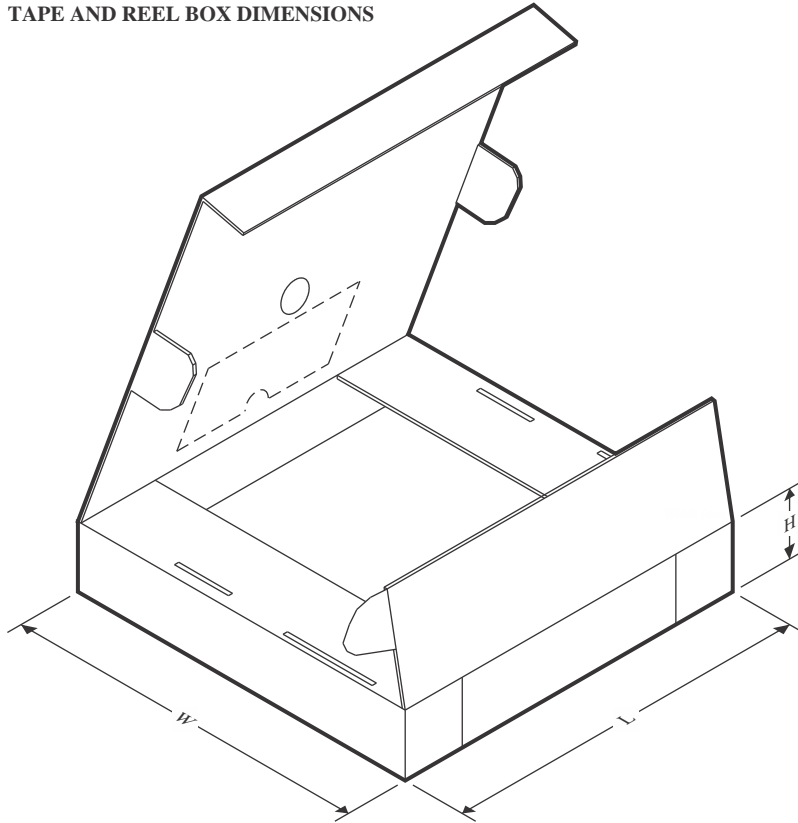
- Catalog - TI's standard catalog product
- Enhanced Product - Supports Defense, Aerospace and Medical Applications
- Military - QML certified for Military and Defense Applications
- Space - Radiation tolerant, ceramic packaging and qualified for use in Space-based application

**TAPE AND REEL INFORMATION**

**QUADRANT ASSIGNMENTS FOR PIN 1 ORIENTATION IN TAPE**


\*All dimensions are nominal

Device	Package Type	Package Drawing	Pins	SPQ	Reel Diameter (mm)	Reel Width W1 (mm)	A0 (mm)	B0 (mm)	K0 (mm)	P1 (mm)	W (mm)	Pin1 Quadrant
SN74HC595DBR	SSOP	DB	16	2000	330.0	16.4	8.35	6.6	2.4	12.0	16.0	Q1
SN74HC595DR	SOIC	D	16	2500	330.0	16.4	6.5	10.3	2.1	8.0	16.0	Q1
SN74HC595DR	SOIC	D	16	2500	330.0	16.4	6.5	10.3	2.1	8.0	16.0	Q1
SN74HC595DRG3	SOIC	D	16	2500	330.0	16.4	6.6	9.3	2.1	8.0	16.0	Q1
SN74HC595DRG4	SOIC	D	16	2500	330.0	16.4	6.5	10.3	2.1	8.0	16.0	Q1
SN74HC595DRG4	SOIC	D	16	2500	330.0	16.4	6.5	10.3	2.1	8.0	16.0	Q1
SN74HC595DWR	SOIC	DW	16	2000	330.0	16.4	10.75	10.7	2.7	12.0	16.0	Q1
SN74HC595NSR	SO	NS	16	2000	330.0	16.4	8.45	10.55	2.5	12.0	16.2	Q1
SN74HC595NSR	SO	NS	16	2000	330.0	16.4	8.2	10.5	2.5	12.0	16.0	Q1
SN74HC595PWR	TSSOP	PW	16	2000	330.0	12.4	6.9	5.6	1.6	8.0	12.0	Q1
SN74HC595PWR	TSSOP	PW	16	2000	330.0	12.4	6.9	5.6	1.6	8.0	12.0	Q1
SN74HC595PWRG4	TSSOP	PW	16	2000	330.0	12.4	6.9	5.6	1.6	8.0	12.0	Q1
SN74HC595PWRG4	TSSOP	PW	16	2000	330.0	12.4	6.9	5.6	1.6	8.0	12.0	Q1

**TAPE AND REEL BOX DIMENSIONS**


\*All dimensions are nominal

Device	Package Type	Package Drawing	Pins	SPQ	Length (mm)	Width (mm)	Height (mm)
SN74HC595DBR	SSOP	DB	16	2000	356.0	356.0	35.0
SN74HC595DR	SOIC	D	16	2500	356.0	356.0	35.0
SN74HC595DR	SOIC	D	16	2500	356.0	356.0	35.0
SN74HC595DRG3	SOIC	D	16	2500	366.0	364.0	50.0
SN74HC595DRG4	SOIC	D	16	2500	356.0	356.0	35.0
SN74HC595DRG4	SOIC	D	16	2500	356.0	356.0	35.0
SN74HC595DWR	SOIC	DW	16	2000	350.0	350.0	43.0
SN74HC595NSR	SO	NS	16	2000	356.0	356.0	35.0
SN74HC595NSR	SO	NS	16	2000	367.0	367.0	38.0
SN74HC595PWR	TSSOP	PW	16	2000	356.0	356.0	35.0
SN74HC595PWR	TSSOP	PW	16	2000	356.0	356.0	35.0
SN74HC595PWRG4	TSSOP	PW	16	2000	356.0	356.0	35.0
SN74HC595PWRG4	TSSOP	PW	16	2000	356.0	356.0	35.0

**TUBE**


\*All dimensions are nominal

Device	Package Name	Package Type	Pins	SPQ	L (mm)	W (mm)	T (μm)	B (mm)
5962-86816012A	FK	LCCC	20	55	506.98	12.06	2030	NA
5962-8681601EA	J	CDIP	16	25	506.98	15.24	13440	NA
5962-8681601VEA	J	CDIP	16	25	506.98	15.24	13440	NA
5962-8681601VFA	W	CFP	16	25	506.98	26.16	6220	NA
SN74HC595N	N	PDIP	16	25	506	13.97	11230	4.32
SN74HC595N	N	PDIP	16	25	506	13.97	11230	4.32
SN74HC595NE4	N	PDIP	16	25	506	13.97	11230	4.32
SN74HC595NE4	N	PDIP	16	25	506	13.97	11230	4.32
SNJ54HC595FK	FK	LCCC	20	55	506.98	12.06	2030	NA
SNJ54HC595J	J	CDIP	16	25	506.98	15.24	13440	NA

## GENERIC PACKAGE VIEW

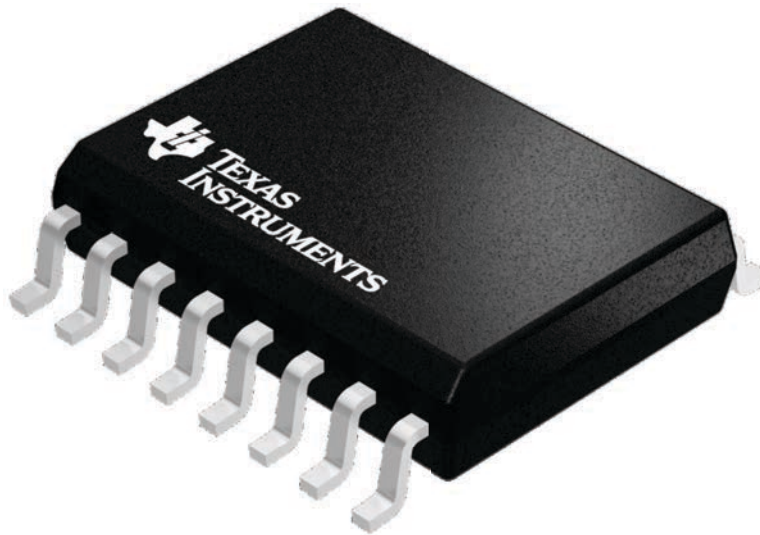
**DW 16**

**SOIC - 2.65 mm max height**

7.5 x 10.3, 1.27 mm pitch

SMALL OUTLINE INTEGRATED CIRCUIT

This image is a representation of the package family, actual package may vary.  
Refer to the product data sheet for package details.



4224780/A

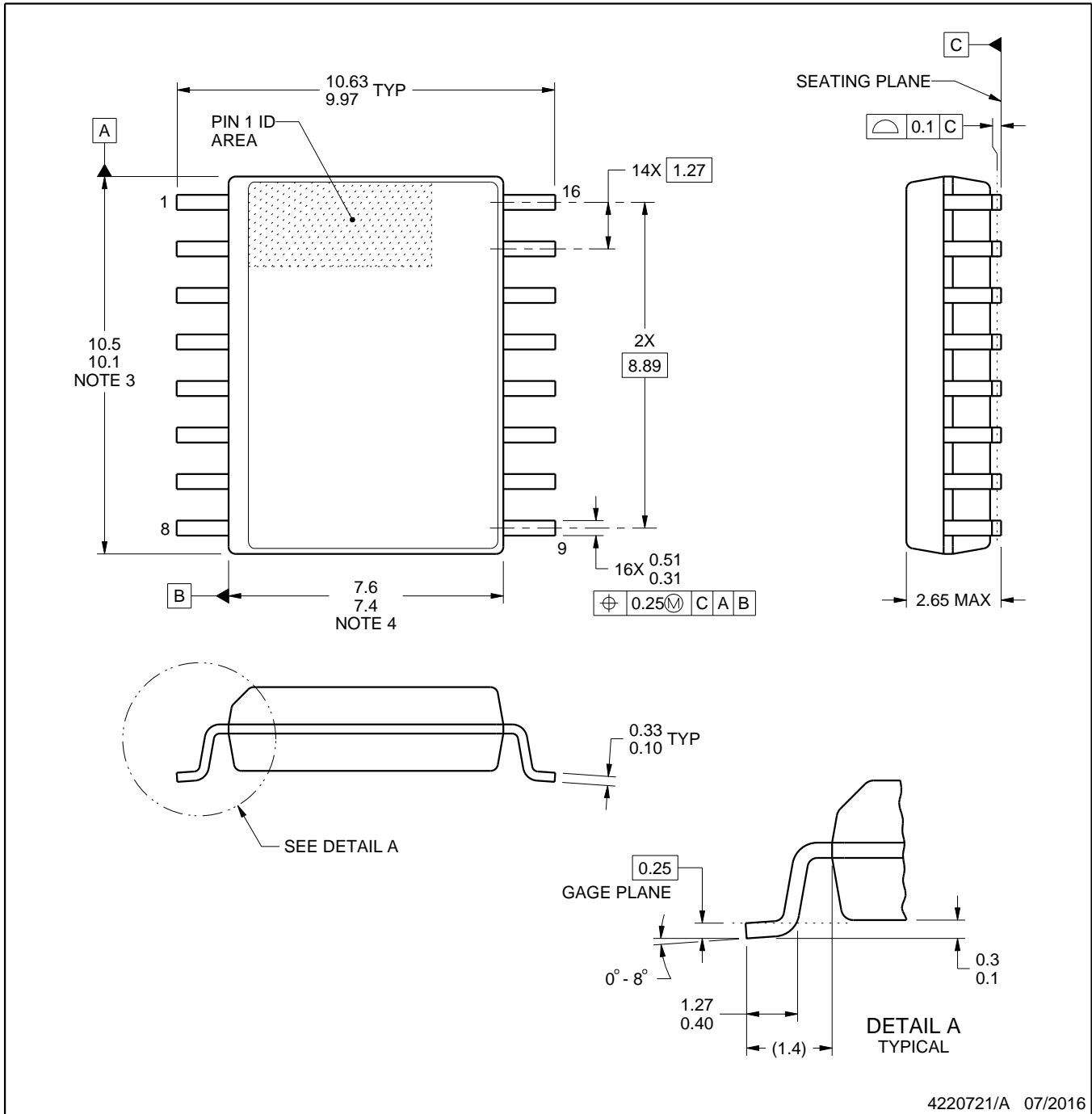


DW0016A

# PACKAGE OUTLINE

SOIC - 2.65 mm max height

SOIC



4220721/A 07/2016

NOTES:

1. All linear dimensions are in millimeters. Dimensions in parenthesis are for reference only. Dimensioning and tolerancing per ASME Y14.5M.
2. This drawing is subject to change without notice.
3. This dimension does not include mold flash, protrusions, or gate burrs. Mold flash, protrusions, or gate burrs shall not exceed 0.15 mm, per side.
4. This dimension does not include interlead flash. Interlead flash shall not exceed 0.25 mm, per side.
5. Reference JEDEC registration MS-013.

# EXAMPLE BOARD LAYOUT

DW0016A

SOIC - 2.65 mm max height

SOIC



LAND PATTERN EXAMPLE  
SCALE:7X



SOLDER MASK DETAILS

4220721/A 07/2016

NOTES: (continued)

6. Publication IPC-7351 may have alternate designs.

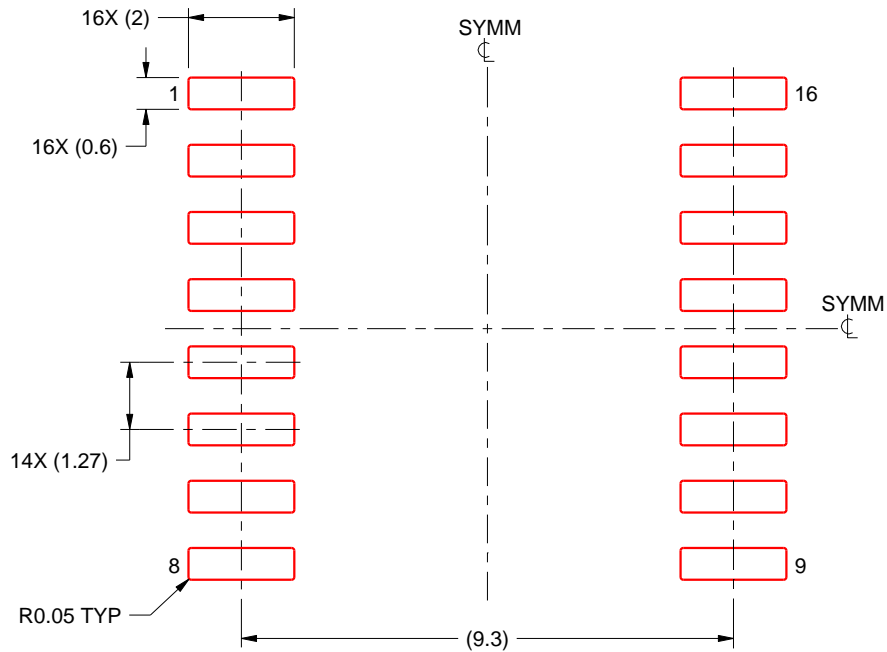
7. Solder mask tolerances between and around signal pads can vary based on board fabrication site.

# EXAMPLE STENCIL DESIGN

DW0016A

SOIC - 2.65 mm max height

SOIC



SOLDER PASTE EXAMPLE  
BASED ON 0.125 mm THICK STENCIL  
SCALE:7X

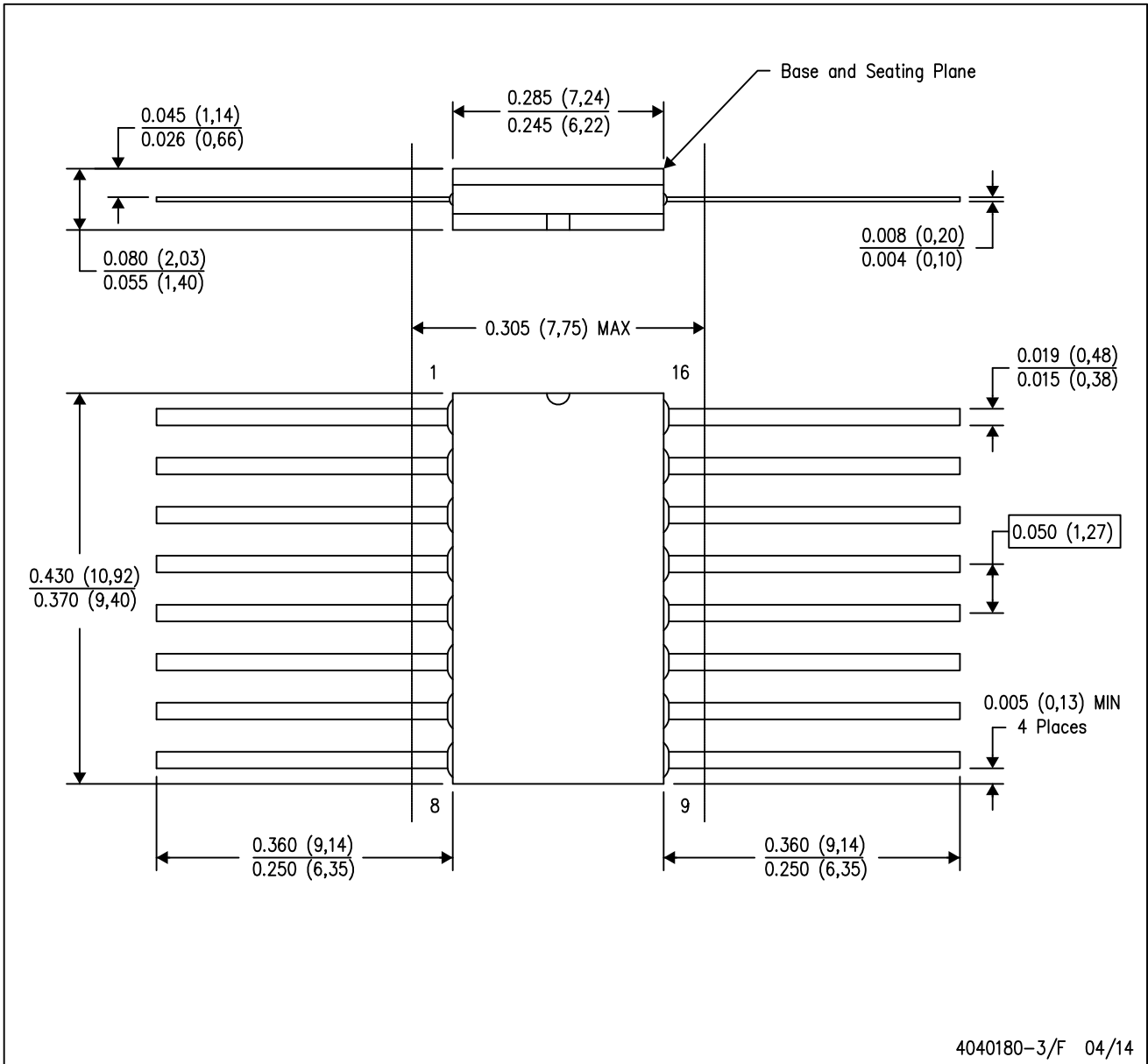
4220721/A 07/2016

NOTES: (continued)

8. Laser cutting apertures with trapezoidal walls and rounded corners may offer better paste release. IPC-7525 may have alternate design recommendations.
9. Board assembly site may have different recommendations for stencil design.

W (R-GDFP-F16)

CERAMIC DUAL FLATPACK



- NOTES:
- A. All linear dimensions are in inches (millimeters).
  - B. This drawing is subject to change without notice.
  - C. This package can be hermetically sealed with a ceramic lid using glass frit.
  - D. Index point is provided on cap for terminal identification only.
  - E. Falls within MIL STD 1835 GDFP2-F16

## GENERIC PACKAGE VIEW

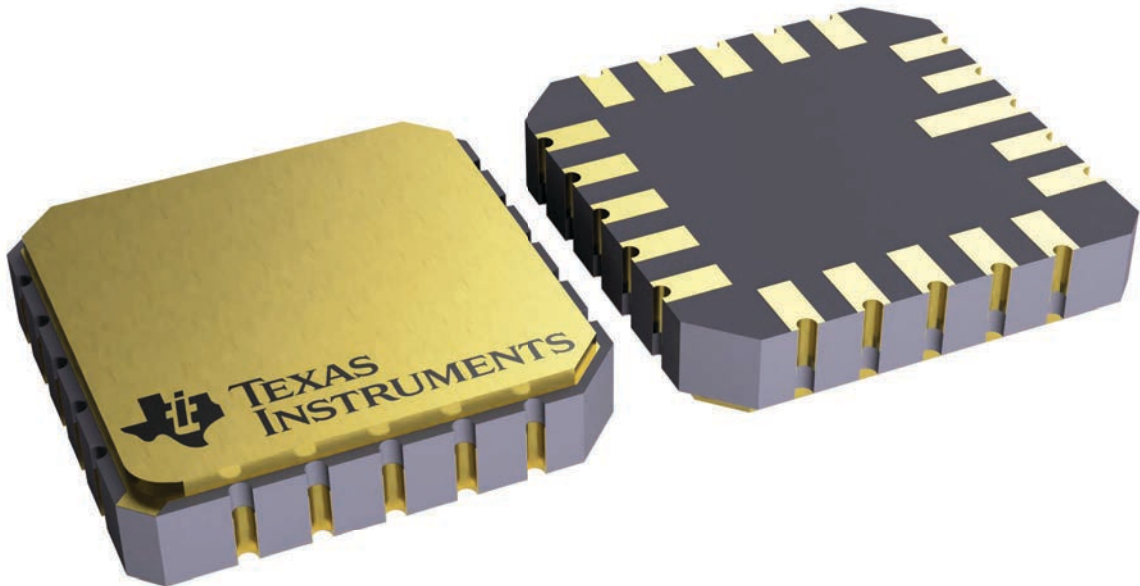
**FK 20**

**LCCC - 2.03 mm max height**

8.89 x 8.89, 1.27 mm pitch

LEADLESS CERAMIC CHIP CARRIER

This image is a representation of the package family, actual package may vary.  
Refer to the product data sheet for package details.



4229370VA\

J (R-GDIP-T\*\*)

14 LEADS SHOWN

CERAMIC DUAL IN-LINE PACKAGE



DIM \ PINS **	14	16	18	20
A	0.300 (7,62) BSC	0.300 (7,62) BSC	0.300 (7,62) BSC	0.300 (7,62) BSC
B MAX	0.785 (19,94)	.840 (21,34)	0.960 (24,38)	1.060 (26,92)
B MIN	—	—	—	—
C MAX	0.300 (7,62)	0.300 (7,62)	0.310 (7,87)	0.300 (7,62)
C MIN	0.245 (6,22)	0.245 (6,22)	0.220 (5,59)	0.245 (6,22)



4040083/F 03/03

- NOTES:
- All linear dimensions are in inches (millimeters).
  - This drawing is subject to change without notice.
  - This package is hermetically sealed with a ceramic lid using glass frit.
  - Index point is provided on cap for terminal identification only on press ceramic glass frit seal only.
  - Falls within MIL STD 1835 GDIP1-T14, GDIP1-T16, GDIP1-T18 and GDIP1-T20.

N (R-PDIP-T\*\*)

PLASTIC DUAL-IN-LINE PACKAGE

16 PINS SHOWN



- NOTES:
- A. All linear dimensions are in inches (millimeters).
  - B. This drawing is subject to change without notice.
  - Falls within JEDEC MS-001, except 18 and 20 pin minimum body length (Dim A).
  - The 20 pin end lead shoulder width is a vendor option, either half or full width.

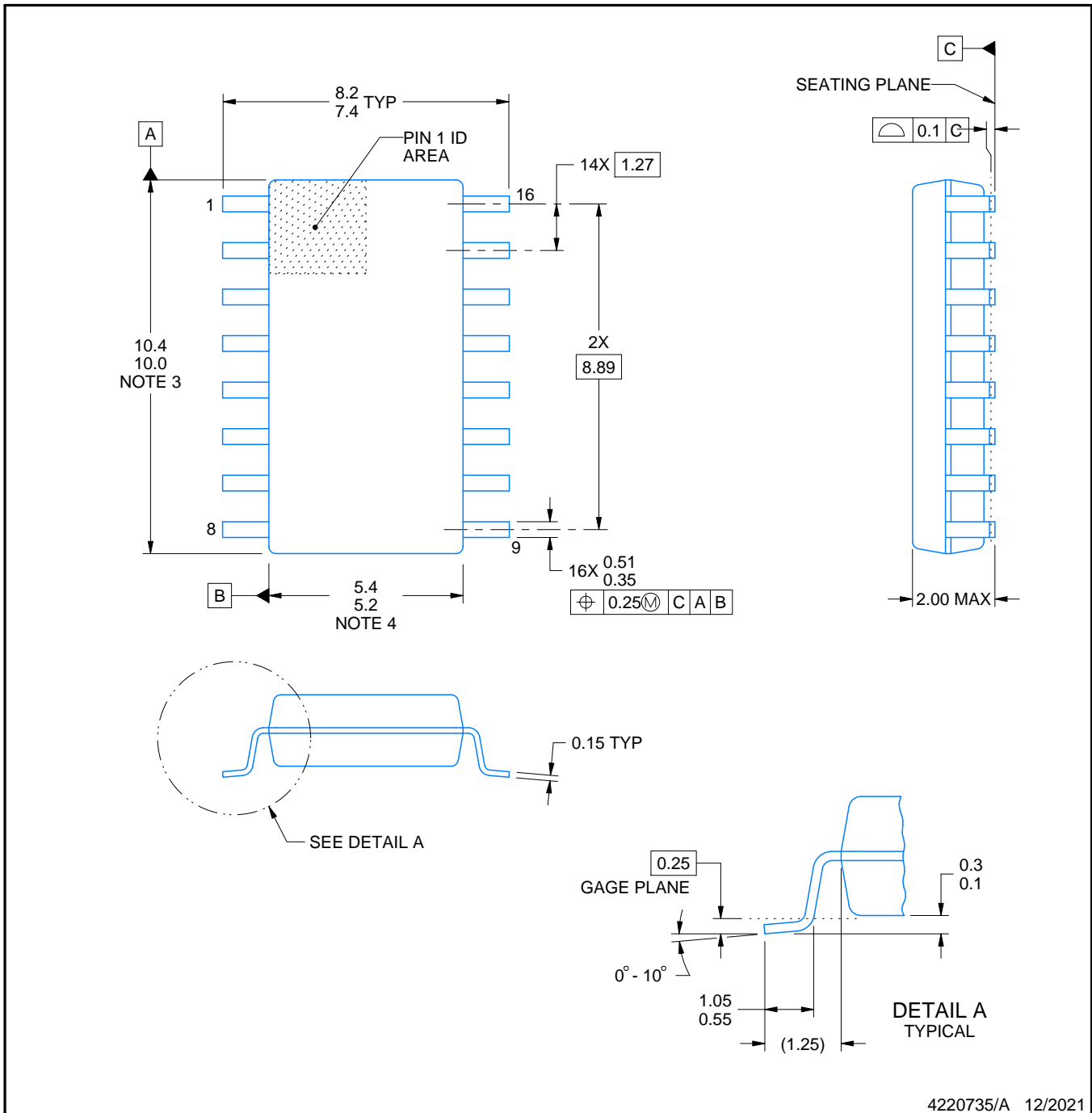


# PACKAGE OUTLINE

## NS0016A

### SOP - 2.00 mm max height

SOP



4220735/A 12/2021

#### NOTES:

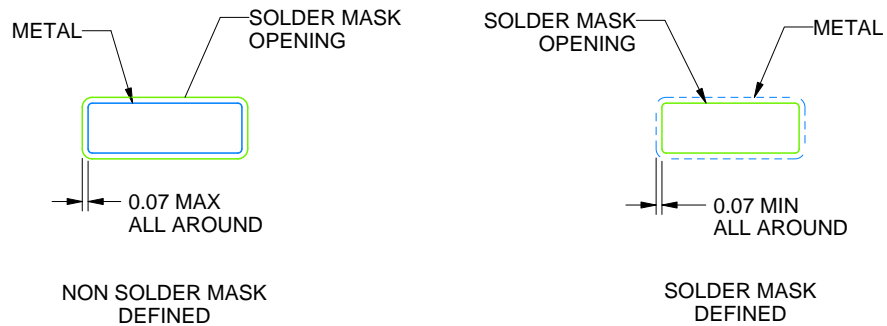
1. All linear dimensions are in millimeters. Dimensions in parenthesis are for reference only. Dimensioning and tolerancing per ASME Y14.5M.
2. This drawing is subject to change without notice.
3. This dimension does not include mold flash, protrusions, or gate burrs. Mold flash, protrusions, or gate burrs shall not exceed 0.15 mm, per side.
4. This dimension does not include interlead flash. Interlead flash shall not exceed 0.25 mm, per side.

# EXAMPLE BOARD LAYOUT

NS0016A

SOP - 2.00 mm max height

SOP



4220735/A 12/2021

NOTES: (continued)

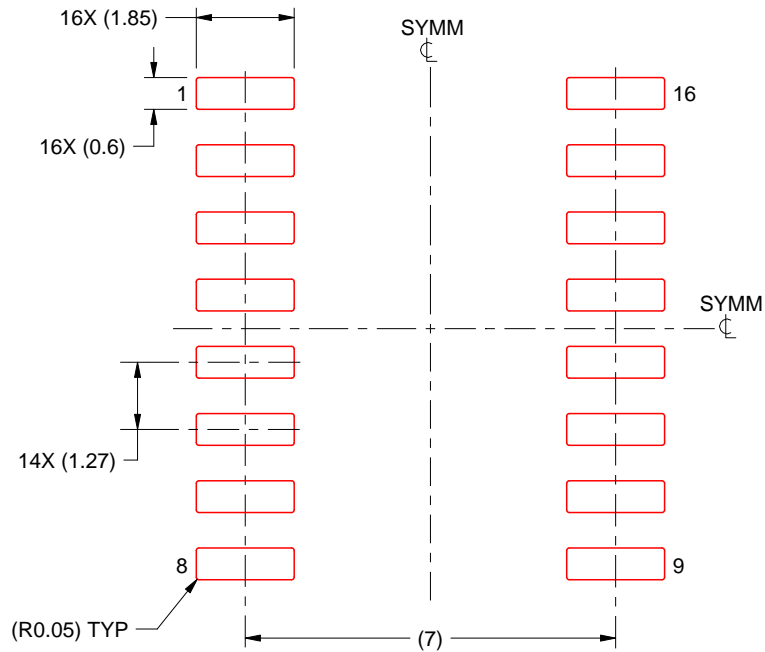
- 5. Publication IPC-7351 may have alternate designs.
- 6. Solder mask tolerances between and around signal pads can vary based on board fabrication site.

# EXAMPLE STENCIL DESIGN

NS0016A

SOP - 2.00 mm max height

SOP



SOLDER PASTE EXAMPLE  
BASED ON 0.125 mm THICK STENCIL  
SCALE:7X

4220735/A 12/2021

NOTES: (continued)

7. Laser cutting apertures with trapezoidal walls and rounded corners may offer better paste release. IPC-7525 may have alternate design recommendations.
8. Board assembly site may have different recommendations for stencil design.

D (R-PDSO-G16)

PLASTIC SMALL OUTLINE



- NOTES:
- A. All linear dimensions are in inches (millimeters).
  - B. This drawing is subject to change without notice.
  - C. Body length does not include mold flash, protrusions, or gate burrs. Mold flash, protrusions, or gate burrs shall not exceed 0.006 (0,15) each side.
  - D. Body width does not include interlead flash. Interlead flash shall not exceed 0.017 (0,43) each side.
  - E. Reference JEDEC MS-012 variation AC.



4220204/A 02/2017

NOTES:

1. All linear dimensions are in millimeters. Any dimensions in parenthesis are for reference only. Dimensioning and tolerancing per ASME Y14.5M.
2. This drawing is subject to change without notice.
3. This dimension does not include mold flash, protrusions, or gate burrs. Mold flash, protrusions, or gate burrs shall not exceed 0.15 mm per side.
4. This dimension does not include interlead flash. Interlead flash shall not exceed 0.25 mm per side.
5. Reference JEDEC registration MO-153.

# EXAMPLE BOARD LAYOUT

PW0016A

TSSOP - 1.2 mm max height

SMALL OUTLINE PACKAGE



LAND PATTERN EXAMPLE  
EXPOSED METAL SHOWN  
SCALE: 10X



SOLDER MASK DETAILS

4220204/A 02/2017

NOTES: (continued)

- 6. Publication IPC-7351 may have alternate designs.
- 7. Solder mask tolerances between and around signal pads can vary based on board fabrication site.

# EXAMPLE STENCIL DESIGN

PW0016A

TSSOP - 1.2 mm max height

SMALL OUTLINE PACKAGE



SOLDER PASTE EXAMPLE  
BASED ON 0.125 mm THICK STENCIL  
SCALE: 10X

4220204/A 02/2017

NOTES: (continued)

8. Laser cutting apertures with trapezoidal walls and rounded corners may offer better paste release. IPC-7525 may have alternate design recommendations.
9. Board assembly site may have different recommendations for stencil design.

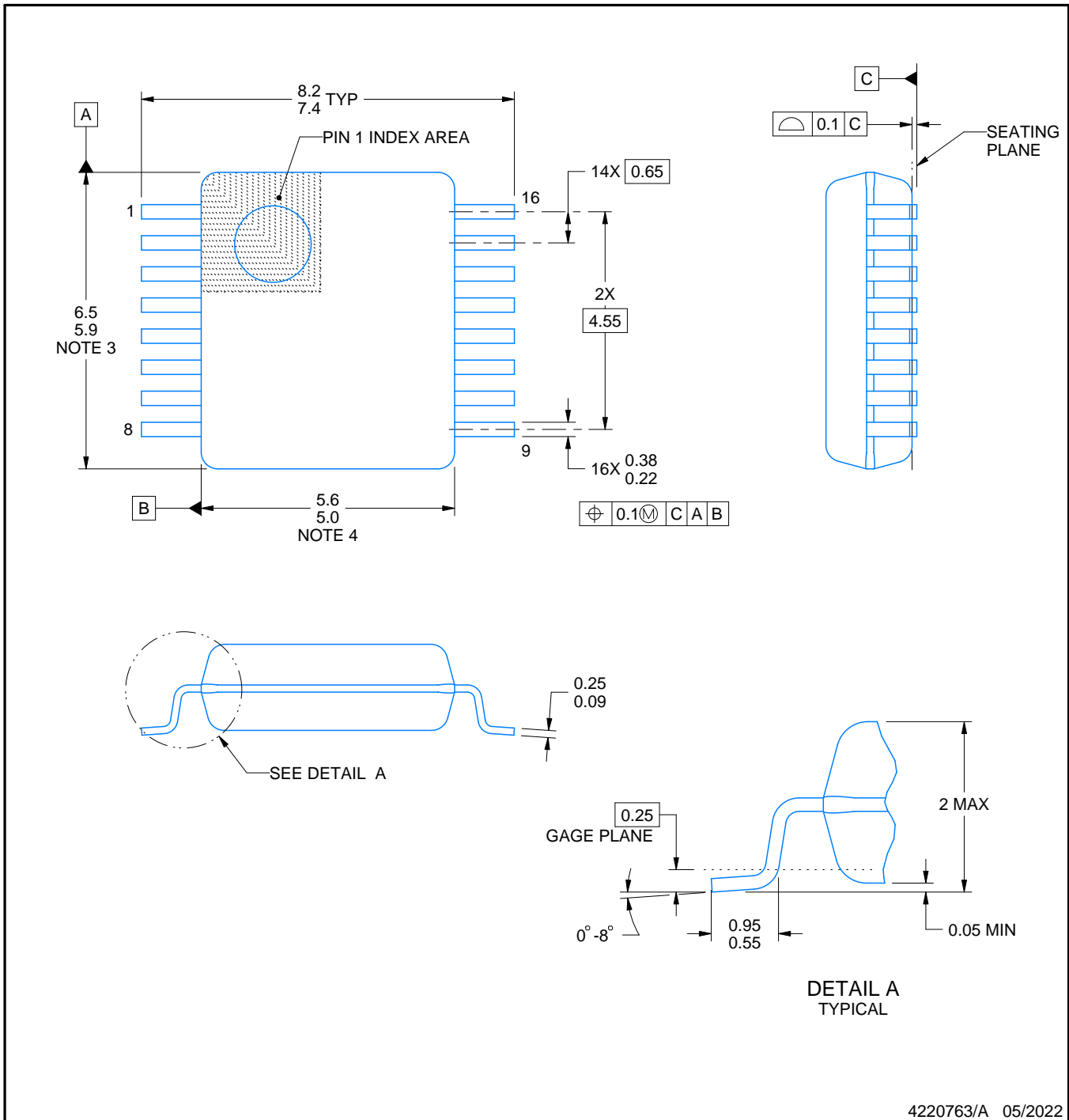
# DB0016A



# PACKAGE OUTLINE

## SSOP - 2 mm max height

SMALL OUTLINE PACKAGE



4220763/A 05/2022

### NOTES:

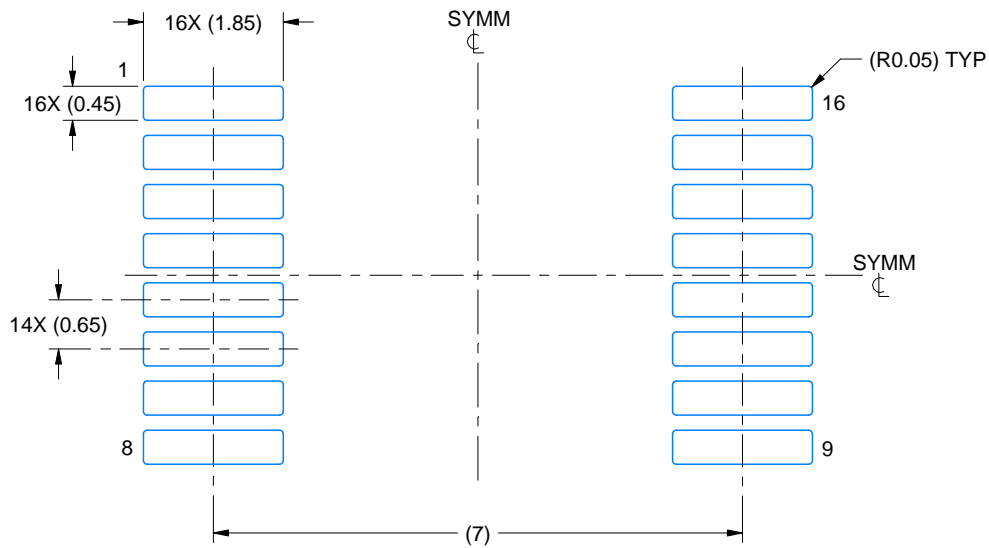
1. All linear dimensions are in millimeters. Any dimensions in parenthesis are for reference only. Dimensioning and tolerancing per ASME Y14.5M.
2. This drawing is subject to change without notice.
3. This dimension does not include mold flash, protrusions, or gate burrs. Mold flash, protrusions, or gate burrs shall not exceed 0.15 mm per side.
4. Reference JEDEC registration MO-150.

# EXAMPLE BOARD LAYOUT

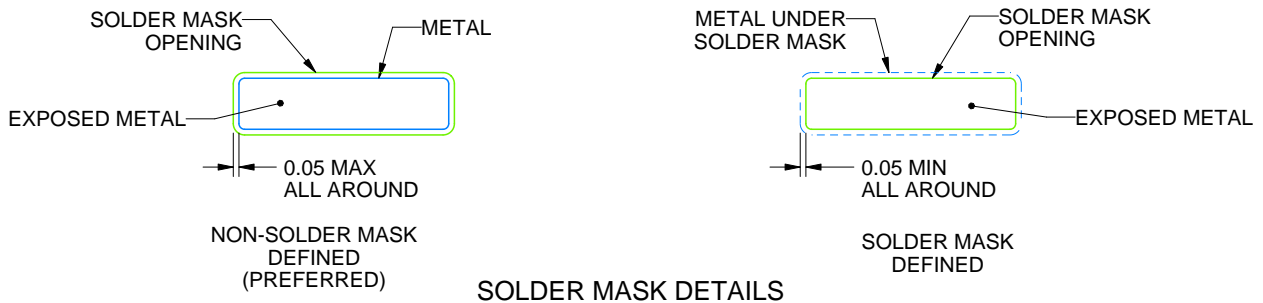
DB0016A

SSOP - 2 mm max height

SMALL OUTLINE PACKAGE



LAND PATTERN EXAMPLE  
EXPOSED METAL SHOWN  
SCALE: 10X



4220763/A 05/2022

NOTES: (continued)

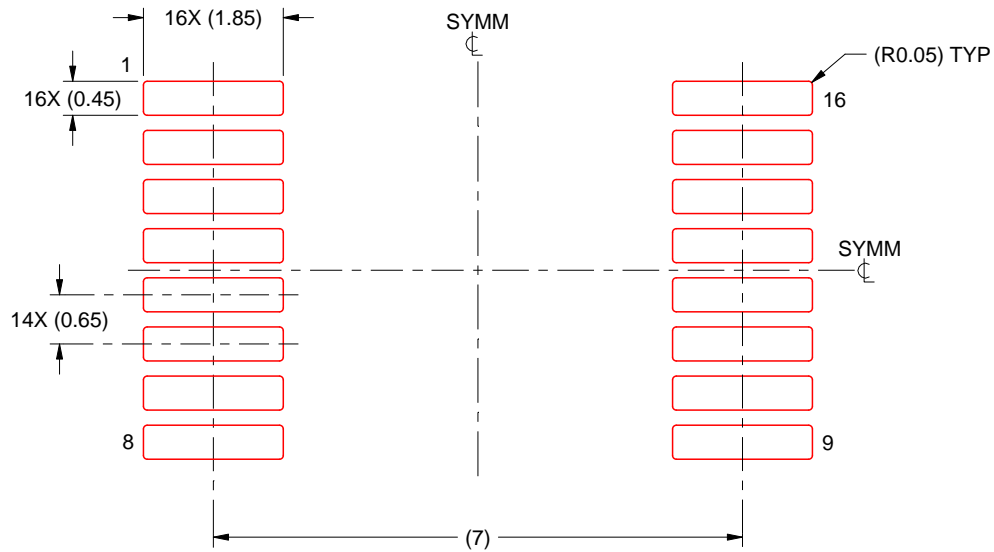
5. Publication IPC-7351 may have alternate designs.
6. Solder mask tolerances between and around signal pads can vary based on board fabrication site.

# EXAMPLE STENCIL DESIGN

DB0016A

SSOP - 2 mm max height

SMALL OUTLINE PACKAGE



SOLDER PASTE EXAMPLE  
BASED ON 0.125 mm THICK STENCIL  
SCALE: 10X

4220763/A 05/2022

NOTES: (continued)

7. Laser cutting apertures with trapezoidal walls and rounded corners may offer better paste release. IPC-7525 may have alternate design recommendations.
8. Board assembly site may have different recommendations for stencil design.

# MECHANICAL DATA

NS (R-PDSO-G\*\*)

PLASTIC SMALL-OUTLINE PACKAGE

14-PINS SHOWN



4040062/C 03/03

- NOTES:
- A. All linear dimensions are in millimeters.
  - B. This drawing is subject to change without notice.
  - C. Body dimensions do not include mold flash or protrusion, not to exceed 0,15.

## IMPORTANT NOTICE AND DISCLAIMER

TI PROVIDES TECHNICAL AND RELIABILITY DATA (INCLUDING DATA SHEETS), DESIGN RESOURCES (INCLUDING REFERENCE DESIGNS), APPLICATION OR OTHER DESIGN ADVICE, WEB TOOLS, SAFETY INFORMATION, AND OTHER RESOURCES "AS IS" AND WITH ALL FAULTS, AND DISCLAIMS ALL WARRANTIES, EXPRESS AND IMPLIED, INCLUDING WITHOUT LIMITATION ANY IMPLIED WARRANTIES OF MERCHANTABILITY, FITNESS FOR A PARTICULAR PURPOSE OR NON-INFRINGEMENT OF THIRD PARTY INTELLECTUAL PROPERTY RIGHTS.

These resources are intended for skilled developers designing with TI products. You are solely responsible for (1) selecting the appropriate TI products for your application, (2) designing, validating and testing your application, and (3) ensuring your application meets applicable standards, and any other safety, security, regulatory or other requirements.

These resources are subject to change without notice. TI grants you permission to use these resources only for development of an application that uses the TI products described in the resource. Other reproduction and display of these resources is prohibited. No license is granted to any other TI intellectual property right or to any third party intellectual property right. TI disclaims responsibility for, and you will fully indemnify TI and its representatives against, any claims, damages, costs, losses, and liabilities arising out of your use of these resources.

TI's products are provided subject to [TI's Terms of Sale](#) or other applicable terms available either on [ti.com](https://www.ti.com) or provided in conjunction with such TI products. TI's provision of these resources does not expand or otherwise alter TI's applicable warranties or warranty disclaimers for TI products.

TI objects to and rejects any additional or different terms you may have proposed.

Mailing Address: Texas Instruments, Post Office Box 655303, Dallas, Texas 75265  
Copyright © 2024, Texas Instruments Incorporated

## Looking for pricing, stock, or lifecycle information?

Click below to explore more details on WIN SOURCE:

 [View SN74HC595N on WIN SOURCE](#)

 [Texas Instruments](#) Information

## Optimize Your Supply Chain with WIN SOURCE Solutions

-  Global Sourcing Solution
-  Obsolete Management
-  Cost Control Management
-  Shortage Management
-  Alternative Solution
-  Excess Inventory Management