



THE DATASHEET OF OP297GSZ



FEATURES

- Low offset voltage: 50 μV maximum
- Low offset voltage drift: 0.6 $\mu\text{V}/^\circ\text{C}$ maximum
- Very low bias current: 100 pA maximum
- Very high open-loop gain: 2000 V/mV minimum
- Low supply current (per amplifier): 625 μA maximum
- Operates from $\pm 2\text{ V}$ to $\pm 20\text{ V}$ supplies
- High common-mode rejection: 120 dB minimum

APPLICATIONS

- Strain gage and bridge amplifiers
- High stability thermocouple amplifiers
- Instrumentation amplifiers
- Photocurrent monitors
- High gain linearity amplifiers
- Long-term integrators/filters
- Sample-and-hold amplifiers
- Peak detectors
- Logarithmic amplifiers
- Battery-powered systems

GENERAL DESCRIPTION

The OP297 is the first dual op amp to pack precision performance into the space saving, industry-standard 8-lead SOIC package. The combination of precision with low power and extremely low input bias current makes the dual OP297 useful in a wide variety of applications.

Precision performance of the OP297 includes very low offset (less than 50 μV) and low drift (less than 0.6 $\mu\text{V}/^\circ\text{C}$). Open-loop gain exceeds 2000 V/mV, ensuring high linearity in every application.

Errors due to common-mode signals are eliminated by the common-mode rejection of over 120 dB, which minimizes offset voltage changes experienced in battery-powered systems. The supply current of the OP297 is under 625 μA .

The OP297 uses a super-beta input stage with bias current cancellation to maintain picoamp bias currents at all temperatures. This is in contrast to FET input op amps whose bias currents start in the picoamp range at 25 $^\circ\text{C}$, but double for every 10 $^\circ\text{C}$ rise in temperature, to reach the nanoamp range above 85 $^\circ\text{C}$. Input bias current of the OP297 is under 100 pA at 25 $^\circ\text{C}$ and is under 450 pA over the military temperature range per amplifier. This part can operate with supply voltages as low as $\pm 2\text{ V}$.

PIN CONFIGURATION

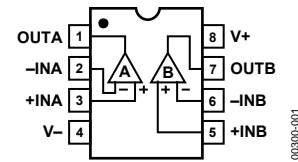

Figure 1.

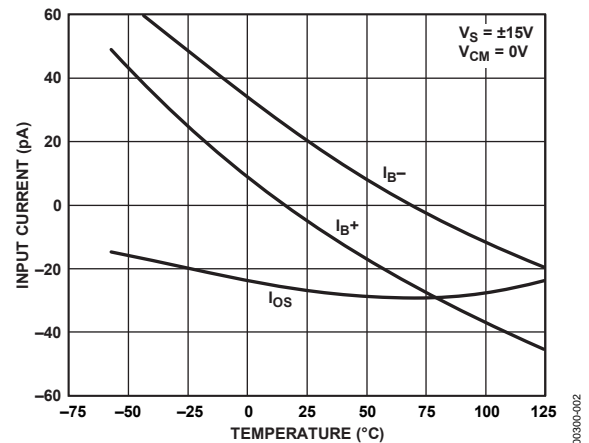

Figure 2. Low Bias Current over Temperature

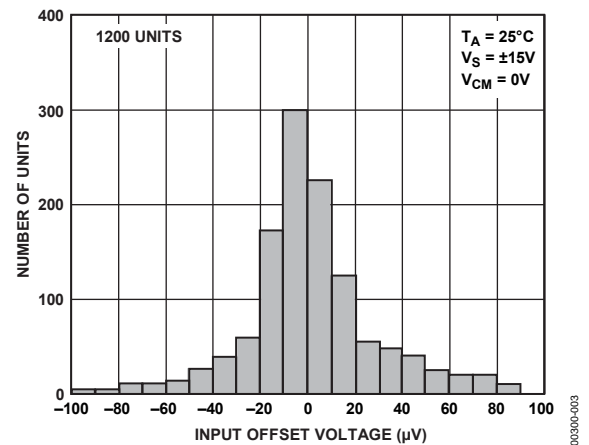

Figure 3. Very Low Offset

Combining precision, low power, and low bias current, the OP297 is ideal for a number of applications, including instrumentation amplifiers, log amplifiers, photodiode preamplifiers, and long term integrators. For a single device, see the [OP97](#); for a quad device, see the [OP497](#).

Rev. G

Information furnished by Analog Devices is believed to be accurate and reliable. However, no responsibility is assumed by Analog Devices for its use, nor for any infringements of patents or other rights of third parties that may result from its use. Specifications subject to change without notice. No license is granted by implication or otherwise under any patent or patent rights of Analog Devices. Trademarks and registered trademarks are the property of their respective owners.

TABLE OF CONTENTS

Features	1	AC Performance	9
Applications.....	1	Guarding and Shielding.....	9
General Description	1	Open-Loop Gain Linearity	10
Pin Configuration.....	1	Application Circuits	11
Revision History	2	Precision Absolute Value Amplifier.....	11
Specifications.....	3	Precision Current Pump.....	11
Electrical Characteristics	3	Precision Positive Peak Detector.....	11
Absolute Maximum Ratings.....	4	Simple Bridge Conditioning Amplifier	11
Thermal Resistance	4	Nonlinear Circuits.....	12
ESD Caution.....	4	Outline Dimensions	13
Typical Performance Characteristics	5	Ordering Guide	14
Applications Information	9		

REVISION HISTORY

4/08—Rev. F to Rev. G

Changes to Table 2 Conditions	3
Changes to Table 2 Power Supply Rejection Parameter	3
Changes to Figure 5, Figure 6, Figure 7	5
Changes to Figure 16.....	6
Updated Outline Dimensions	13
Changes to Ordering Guide	14

2/06—Rev. E to Rev. F

Updated Format	Universal
Changes to Features.....	1
Deleted OP297 Spice Macro Model Section	9
Updated Outline Dimensions	13
Changes to Ordering Guide	14

7/03—Rev. D to Rev. E

Changes to TPCs 13 and 16	4
Edits to Figures 12 and 14	8
Changes to Nonlinear Circuits Section	8

10/02—Rev. C to Rev. D

Edits to Figure 16.....	6
-------------------------	---

10/02—Rev. B to Rev. C

Edits to Specifications	2
Deleted Wafer Test Limits	3
Deleted Dice Characteristics.....	3
Deleted Absolute Maximum Ratings.....	4
Edits to Ordering Guide	4
Updated Outline Dimensions	12

SPECIFICATIONS

ELECTRICAL CHARACTERISTICS

@ $V_S = \pm 15\text{ V}$, $T_A = 25^\circ\text{C}$, unless otherwise noted.

Table 1.

Parameter	Symbol	Conditions	OP297E			OP297F			OP297G			Unit
			Min	Typ	Max	Min	Typ	Max	Min	Typ	Max	
Input Offset Voltage	V_{OS}		25	50		50	100		80	200	μV	
Long-Term Input Voltage Stability			0.1			0.1			0.1		$\mu\text{V}/\text{month}$	
Input Offset Current	I_{OS}	$V_{CM} = 0\text{ V}$	20	100		35	150		50	200	pA	
Input Bias Current	I_B	$V_{CM} = 0\text{ V}$	+20	± 100		+35	± 150		+50	± 200	pA	
Input Noise Voltage	$e_{n\text{ p-p}}$	0.1 Hz to 10 Hz	0.5			0.5			0.5		$\mu\text{V p-p}$	
Input Noise Voltage Density	e_n	$f_{OUT} = 10\text{ Hz}$	20			20			20		$\text{nV}/\sqrt{\text{Hz}}$	
		$f_{OUT} = 1000\text{ Hz}$	17			17			17		$\text{nV}/\sqrt{\text{Hz}}$	
Input Noise Current Density	i_n	$f_{OUT} = 10\text{ Hz}$	20			20			20		$\text{fA}/\sqrt{\text{Hz}}$	
Input Resistance												
Differential Mode	R_{IN}		30			30			30		$\text{M}\Omega$	
Common-Mode	R_{INCM}		500			500			500		$\text{G}\Omega$	
Large Signal Voltage Gain	A_{VO}	$V_{OUT} = \pm 10\text{ V}$, $R_L = 2\text{ k}\Omega$	2000	4000		1500	3200		1200	3200	V/mV	
Input Voltage Range ¹	V_{CM}		± 13	± 14		± 13	± 14		± 13	± 14	V	
Common-Mode Rejection	CMRR	$V_{CM} = \pm 13\text{ V}$	120	140		114	135		114	135	dB	
Power Supply Rejection	PSRR	$V_S = \pm 2\text{ V}$ to $\pm 20\text{ V}$	120	130		114	125		114	125	dB	
Output Voltage Swing	V_{OUT}	$R_L = 10\text{ k}\Omega$	± 13	± 14		± 13	± 14		± 13	± 14	V	
		$R_L = 2\text{ k}\Omega$	± 13	± 13.7		± 13	± 13.7		± 13	± 13.7	V	
Supply Current per Amplifier	I_{SY}	No load	525	625		525	625		525	625	μA	
Supply Voltage	V_S	Operating range	± 2	± 20		± 2	± 20		± 2	± 20	V	
Slew Rate	SR		0.05	0.15		0.05	0.15		0.05	0.15	$\text{V}/\mu\text{s}$	
Gain Bandwidth Product	GBWP	$A_V = +1$	500			500			500		kHz	
Channel Separation	CS	$V_{OUT} = 20\text{ V p-p}$, $f_{OUT} = 10\text{ Hz}$	150			150			150		dB	
Input Capacitance	C_{IN}		3			3			3		pF	

¹ Guaranteed by CMR test.

@ $V_S = \pm 15\text{ V}$, $-40^\circ\text{C} \leq T_A \leq +85^\circ\text{C}$, unless otherwise noted.

Table 2.

Parameter	Symbol	Conditions	OP297E			OP297F			OP297G			Unit
			Min	Typ	Max	Min	Typ	Max	Min	Typ	Max	
Input Offset Voltage	V_{OS}		35	100		80	300		110	400	μV	
Average Input Offset Voltage Drift	TCV_{OS}		0.2	0.6		0.5	2.0		0.6	2.0	$\mu\text{V}/^\circ\text{C}$	
Input Offset Current	I_{OS}	$V_{CM} = 0\text{ V}$	50	450		80	750		80	750	pA	
Input Bias Current	I_B	$V_{CM} = 0\text{ V}$	+50	± 450		+80	± 750		+80	± 750	pA	
Large Signal Voltage Gain	A_{VO}	$V_{OUT} = \pm 10\text{ V}$, $R_L = 2\text{ k}\Omega$	1200	3200		1000	2500		800	2500	V/mV	
Input Voltage Range ¹	V_{CM}		± 13	± 13.5		± 13	± 13.5		± 13	± 13.5	V	
Common-Mode Rejection	CMRR	$V_{CM} = \pm 13\text{ V}$	114	130		108	130		108	130	dB	
Power Supply Rejection	PSRR	$V_S = \pm 2.5\text{ V}$ to $\pm 20\text{ V}$	114			108			108		dB	
Output Voltage Swing	V_{OUT}	$R_L = 10\text{ k}\Omega$	± 13	± 13.4		± 13	± 13.4		± 13	± 13.4	V	
Supply Current per Amplifier	I_{SY}	No load	550	750		550	750		550	750	μA	
Supply Voltage	V_S	Operating range	± 2.5	± 20		± 2.5	± 20		± 2.5	± 20	V	

¹ Guaranteed by CMR test.

ABSOLUTE MAXIMUM RATINGS

Table 3.

Parameter	Rating
Supply Voltage	±20 V
Input Voltage ¹	±20 V
Differential Input Voltage ¹	40 V
Output Short-Circuit Duration	Indefinite
Storage Temperature Range	
Z-Suffix	−65°C to +175°C
P-Suffix, S-Suffix	−65°C to +150°C
Operating Temperature Range	
OP297E (Z-Suffix)	−40°C to +85°C
OP297F, OP297G (P-Suffix, S-Suffix)	−40°C to +85°C
Junction Temperature	
Z-Suffix	−65°C to +175°C
P-Suffix, S-Suffix	−65°C to +150°C
Lead Temperature (Soldering, 60 sec)	300°C

¹ For supply voltages less than ±20 V, the absolute maximum input voltage is equal to the supply voltage.

Stresses above those listed under Absolute Maximum Ratings may cause permanent damage to the device. This is a stress rating only; functional operation of the device at these or any other conditions above those indicated in the operational section of this specification is not implied. Exposure to absolute maximum rating conditions for extended periods may affect device reliability.

THERMAL RESISTANCE

θ_{JA} is specified for worst-case mounting conditions, that is, θ_{JA} is specified for device in socket for CERDIP and PDIP packages; θ_{JA} is specified for device soldered to printed circuit board for the SOIC package.

Table 4. Thermal Resistance

Package Type	θ_{JA}	θ_{JC}	Unit
8-Lead CERDIP (Z-Suffix)	134	12	°C/W
8-Lead PDIP (P-Suffix)	96	37	°C/W
8-Lead SOIC (S-Suffix)	150	41	°C/W

ESD CAUTION



ESD (electrostatic discharge) sensitive device. Charged devices and circuit boards can discharge without detection. Although this product features patented or proprietary protection circuitry, damage may occur on devices subjected to high energy ESD. Therefore, proper ESD precautions should be taken to avoid performance degradation or loss of functionality.

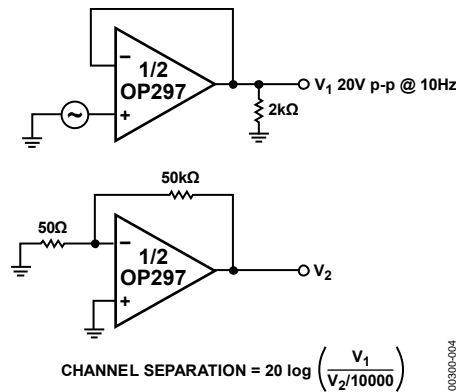

Figure 4. Channel Separation Test Circuit

00300-004

TYPICAL PERFORMANCE CHARACTERISTICS

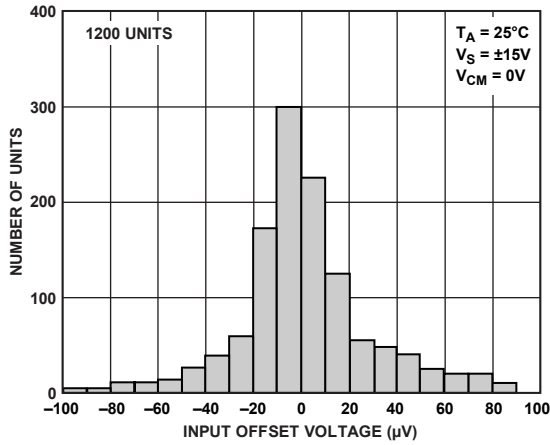

Figure 5. Typical Distribution of Input Offset Voltage

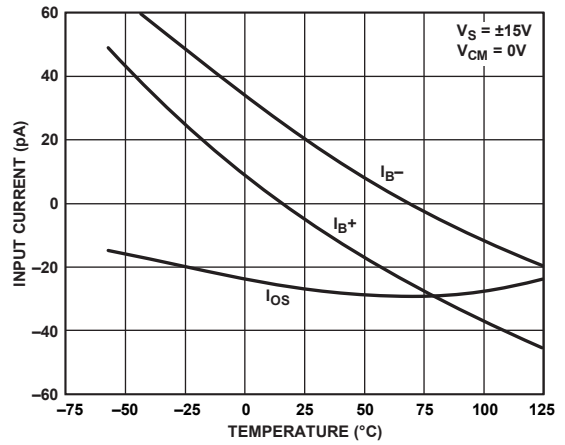

Figure 8. Input Bias, Offset Current vs. Temperature

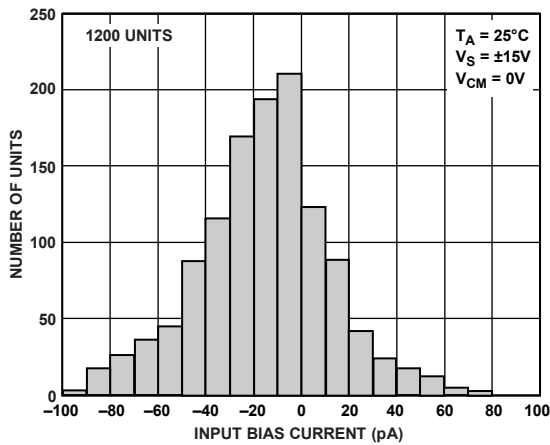

Figure 6. Typical Distribution of Input Bias Current

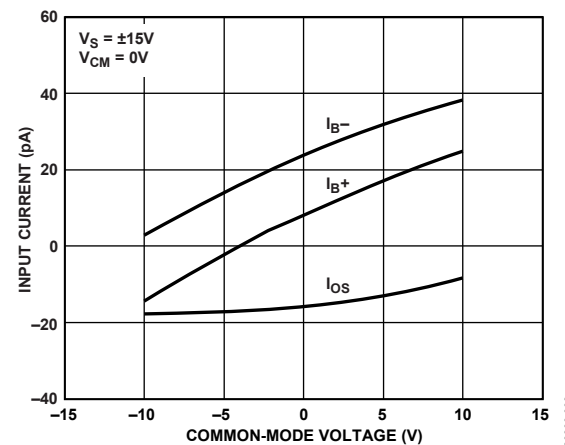

Figure 9. Input Bias, Offset Current vs. Common-Mode Voltage

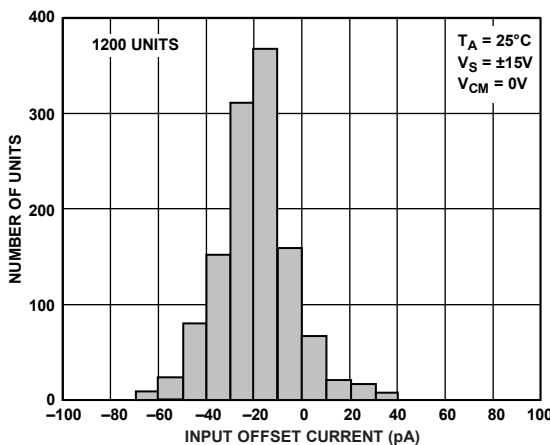

Figure 7. Typical Distribution of Input Offset Current

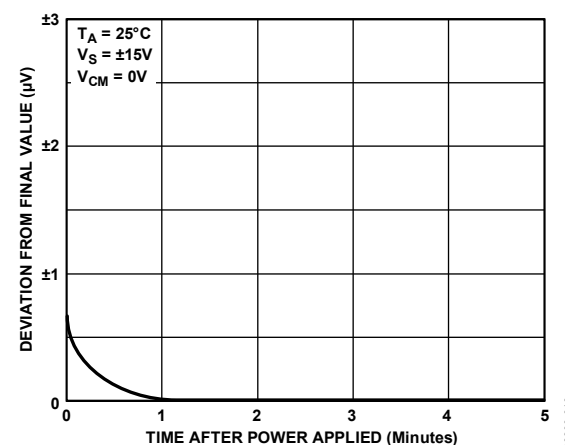

Figure 10. Input Offset Voltage Warm-Up Drift

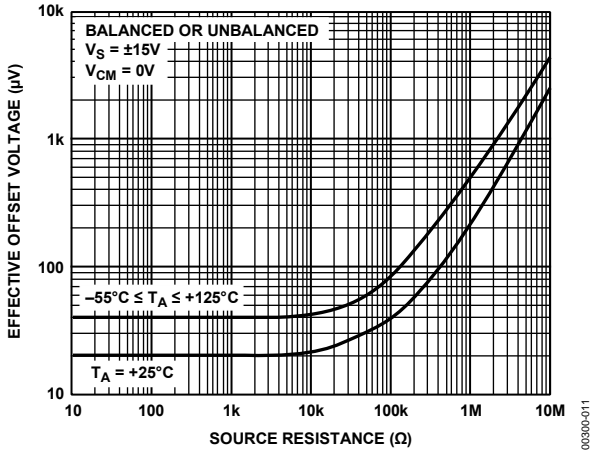

Figure 11. Effective Offset Voltage vs. Source Resistance

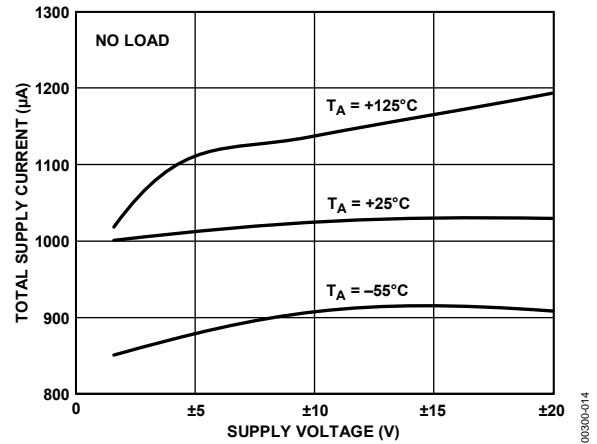

Figure 14. Total Supply Current vs. Supply Voltage

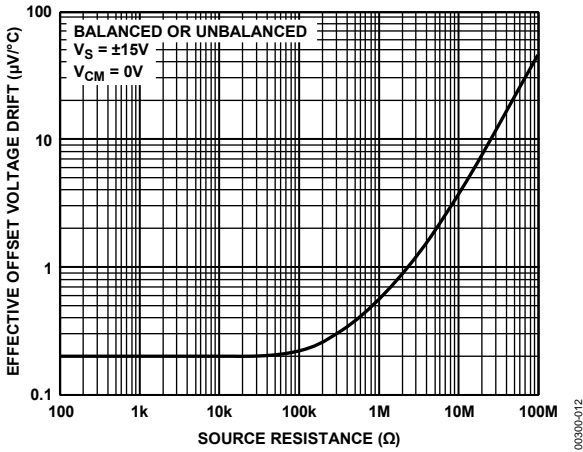

Figure 12. Effective TCV_{OS} vs. Source Resistance

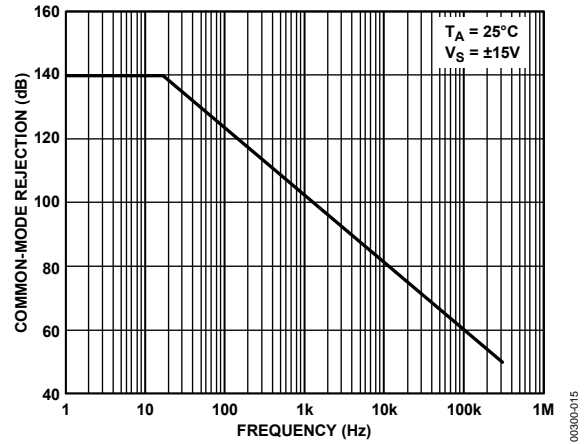

Figure 15. Common-Mode Rejection vs. Frequency

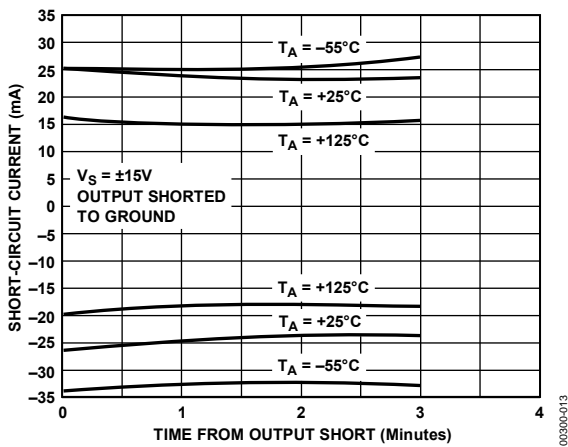

Figure 13. Short-Circuit Current vs. Time, Temperature

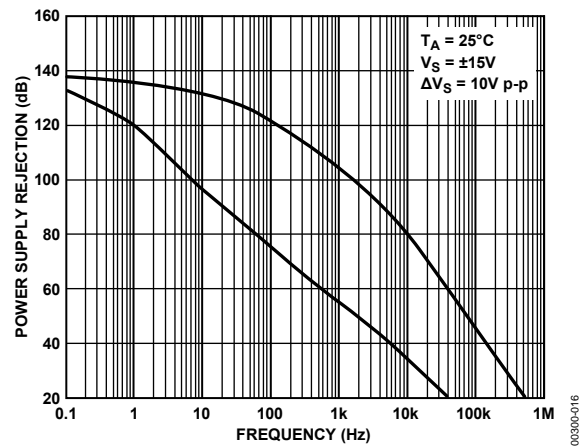

Figure 16. Power Supply Rejection vs. Frequency

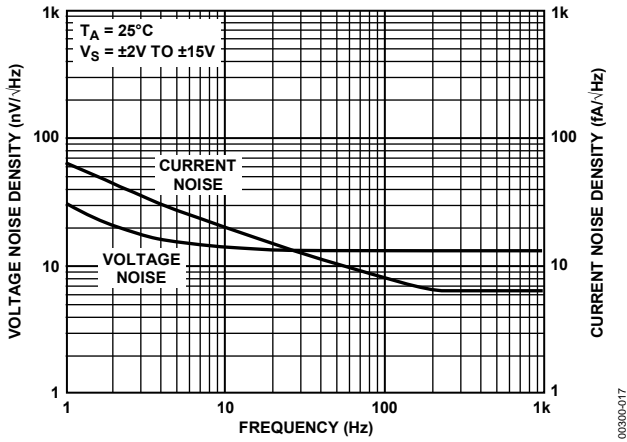

Figure 17. Voltage Noise Density and Current Noise Density vs. Frequency

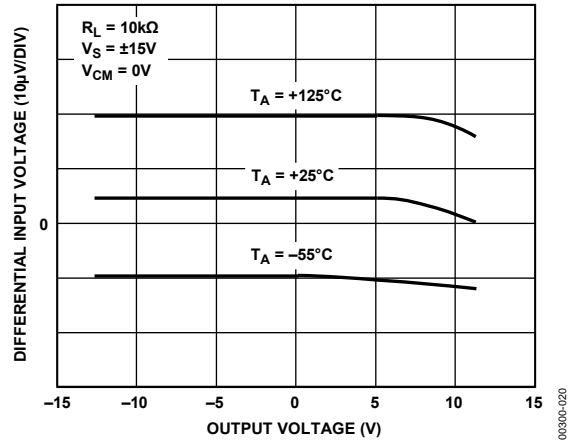

Figure 20. Differential Input Voltage vs. Output Voltage

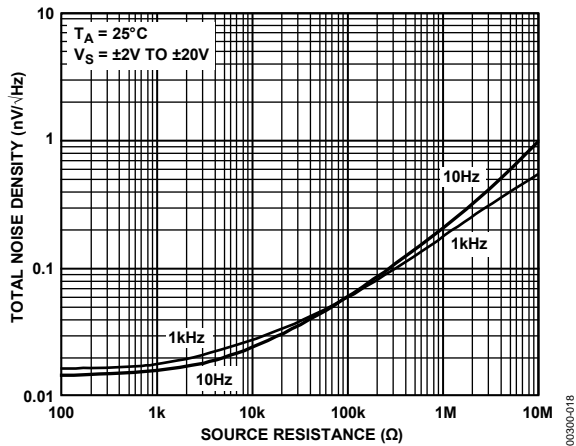

Figure 18. Total Noise Density vs. Source Resistance

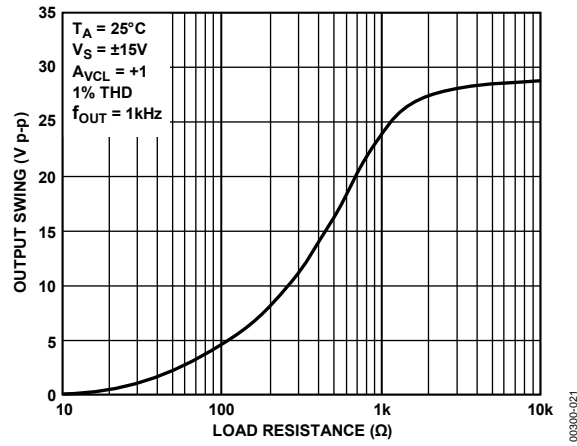

Figure 21. Output Swing vs. Load Resistance

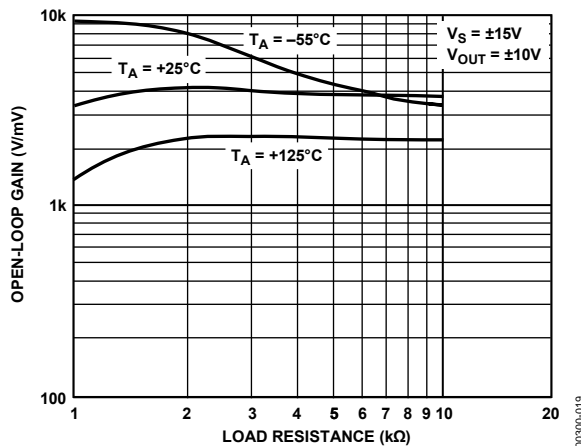

Figure 19. Open-Loop Gain vs. Load Resistance

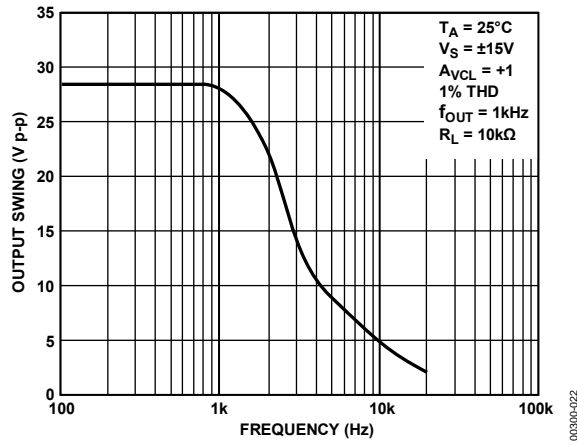

Figure 22. Maximum Output Swing vs. Frequency

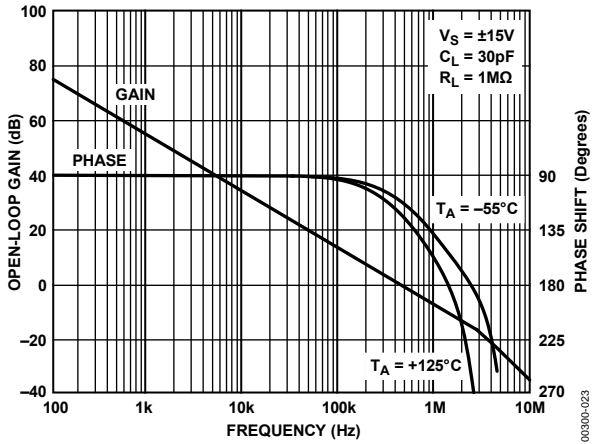

Figure 23. Open-Loop Gain, Phase vs. Frequency

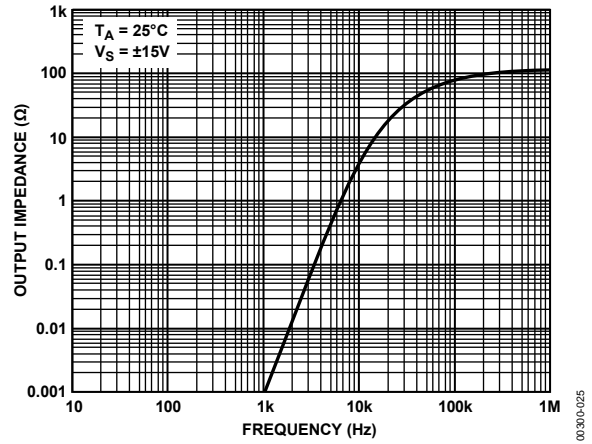

Figure 25. Open-Loop Output Impedance vs. Frequency

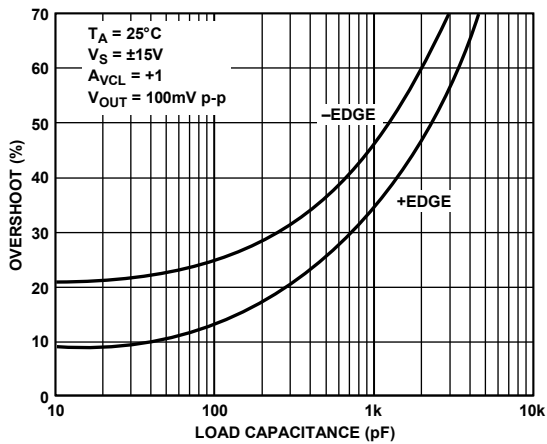

Figure 24. Small Signal Overshoot vs. Load Capacitance

APPLICATIONS INFORMATION

Extremely low bias current over a wide temperature range makes the OP297 attractive for use in sample-and-hold amplifiers, peak detectors, and log amplifiers that must operate over a wide temperature range. Balancing input resistances is unnecessary with the OP297. Offset voltage and TCV_{OS} are degraded only minimally by high source resistance, even when unbalanced.

The input pins of the OP297 are protected against large differential voltage by back-to-back diodes and current-limiting resistors. Common-mode voltages at the inputs are not restricted and can vary over the full range of the supply voltages used.

The OP297 requires very little operating headroom about the supply rails and is specified for operation with supplies as low as 2 V. Typically, the common-mode range extends to within 1 V of either rail. The output typically swings to within 1 V of the rails when using a 10 kΩ load.

AC PERFORMANCE

The ac characteristics of the OP297 are highly stable over its full operating temperature range. Unity gain small signal response is shown in Figure 26. Extremely tolerant of capacitive loading on the output, the OP297 displays excellent response with 1000 pF loads (see Figure 27).

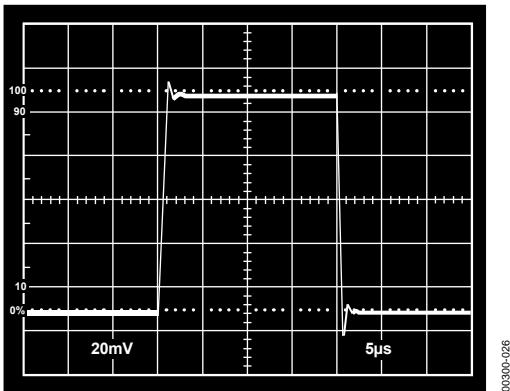

Figure 26. Small Signal Transient Response ($C_L = 100 \text{ pF}$, $A_{VCL} = +1$)

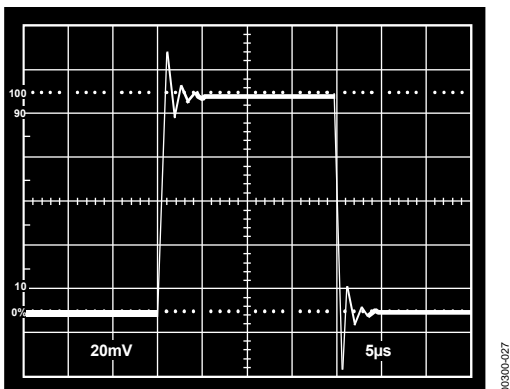

Figure 27. Small Signal Transient Response ($C_L = 1000 \text{ pF}$, $A_{VCL} = +1$)

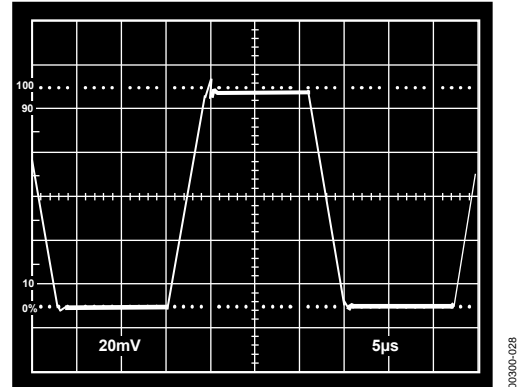

Figure 28. Large Signal Transient Response ($A_{VCL} = +1$)

GUARDING AND SHIELDING

To maintain the extremely high input impedances of the OP297, care is taken in circuit board layout and manufacturing. Board surfaces must be kept scrupulously clean and free of moisture. Conformal coating is recommended to provide a humidity barrier. Even a clean PCB can have 100 pA of leakage currents between adjacent traces, therefore guard rings should be used around the inputs. Guard traces operate at a voltage close to that on the inputs, as shown in Figure 29, to minimize leakage currents. In noninverting applications, the guard ring should be connected to the common-mode voltage at the inverting input. In inverting applications, both inputs remain at ground, so the guard trace should be grounded. Guard traces should be placed on both sides of the circuit board.

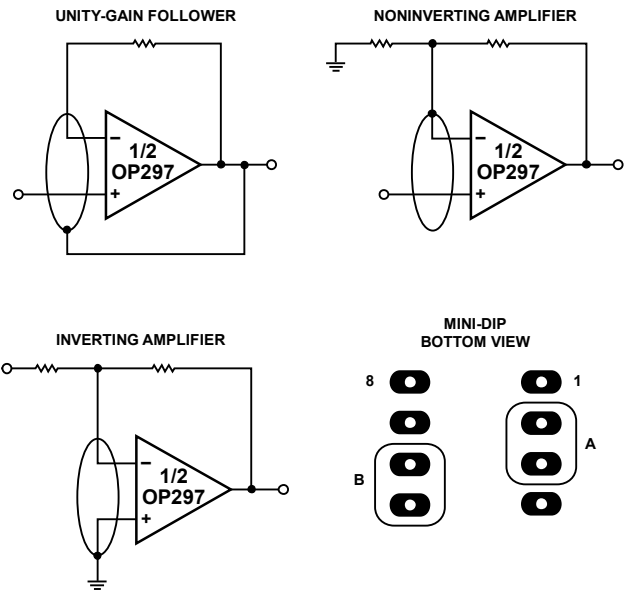

Figure 29. Guard Ring Layout and Considerations

OP297

OPEN-LOOP GAIN LINEARITY

The OP297 has both an extremely high gain of 2000 V/mV minimum and constant gain linearity. This enhances the precision of the OP297 and provides for very high accuracy in high closed-loop gain applications. Figure 30 illustrates the typical open-loop gain linearity of the OP297 over the military temperature range.

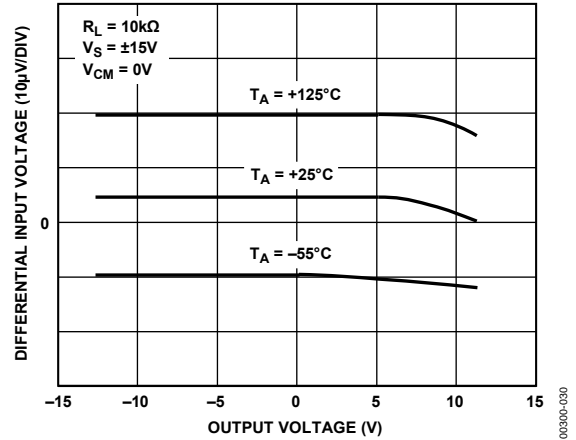

Figure 30. Open-Loop Linearity of the OP297

APPLICATION CIRCUITS

PRECISION ABSOLUTE VALUE AMPLIFIER

The circuit in Figure 31 is a precision absolute value amplifier with an input impedance of 30 MΩ. The high gain and low TCV_{OS} of the OP297 ensure accurate operation with microvolt input signals. In this circuit, the input always appears as a common-mode signal to the op amps. The CMR of the OP297 exceeds 120 dB, yielding an error of less than 2 ppm.

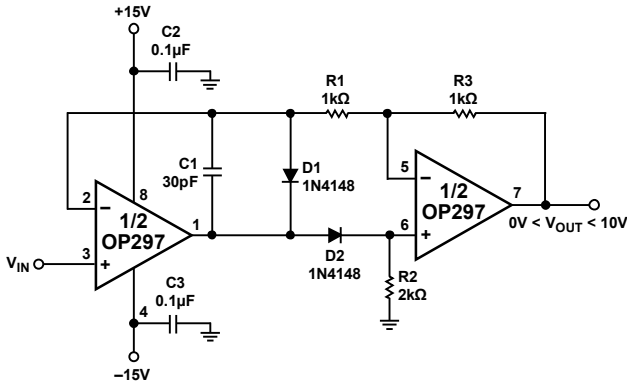

Figure 31. Precision Absolute Value Amplifier

PRECISION CURRENT PUMP

Maximum output current of the precision current pump shown in Figure 32 is ±10 mA. Voltage compliance is ±10 V with ±15 V supplies. Output impedance of the current transmitter exceeds 3 MΩ with linearity better than 16 bits. R1 through R4 should be matched resistors.

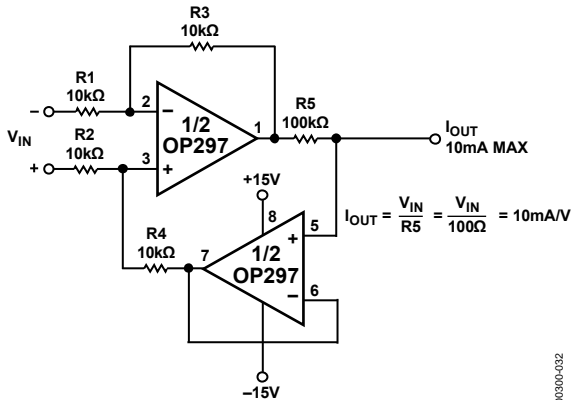

Figure 32. Precision Current Pump

PRECISION POSITIVE PEAK DETECTOR

In Figure 33, the C_H must be of polystyrene, Teflon®, or polyethylene to minimize dielectric absorption and leakage. The droop rate is determined by the size of C_H and the bias current of the OP297.

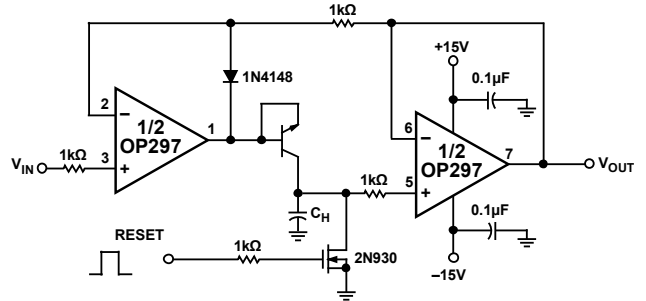

Figure 33. Precision Positive Peak Detector

SIMPLE BRIDGE CONDITIONING AMPLIFIER

Figure 34 shows a simple bridge conditioning amplifier using the OP297. The transfer function is

$$V_{OUT} = V_{REF} \left(\frac{\Delta R}{R + \Delta R} \right) \frac{R_F}{R}$$

The REF43 provides an accurate and stable reference voltage for the bridge. To maintain the highest circuit accuracy, R_F should be 0.1% or better with a low temperature coefficient.

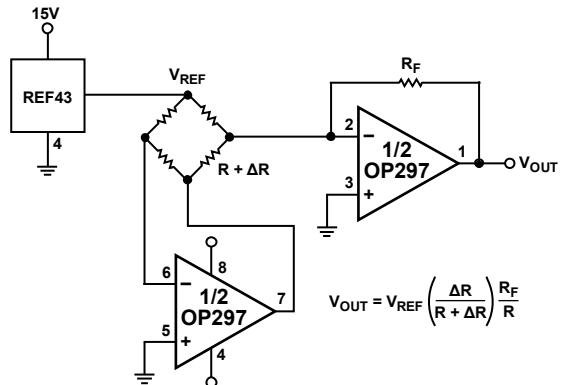

Figure 34. Simple Bridge Condition Amplifier Using the OP297

NONLINEAR CIRCUITS

Due to its low input bias currents, the OP297 is an ideal log amplifier in nonlinear circuits such as the square and square root circuits shown in Figure 35 and Figure 36. Using the squaring circuit of Figure 35 as an example, the analysis begins by writing a voltage loop equation across Transistor Q1, Transistor Q2, Transistor Q3, and Transistor Q4.

$$V_{T1} \ln\left(\frac{I_{IN}}{I_{S1}}\right) + V_{T2} \ln\left(\frac{I_{IN}}{I_{S2}}\right) = V_{T3} \ln\left(\frac{I_{OUT}}{I_{S3}}\right) + V_{T4} \ln\left(\frac{I_{REF}}{I_{S4}}\right)$$

All the transistors of the MAT04 are precisely matched and at the same temperature, so the I_S and V_T terms cancel, where

$$2\ln I_{IN} = \ln I_{OUT} + \ln I_{REF} = \ln(I_{OUT} \times I_{REF})$$

Exponentiating both sides of the equation leads to

$$I_{OUT} = \frac{(I_{IN})^2}{I_{REF}}$$

Op Amp A2 forms a current-to-voltage converter, which gives $V_{OUT} = R2 \times I_{OUT}$. Substituting $(V_{IN}/R1)$ for I_{IN} and the previous equation for I_{OUT} yields

$$V_{OUT} = \left(\frac{R2}{I_{REF}}\right) \left(\frac{V_{IN}}{R1}\right)^2$$

A similar analysis made for the square root circuit of Figure 36 leads to its transfer function

$$V_{OUT} = R2 \sqrt{\frac{(V_{IN})(I_{REF})}{R1}}$$

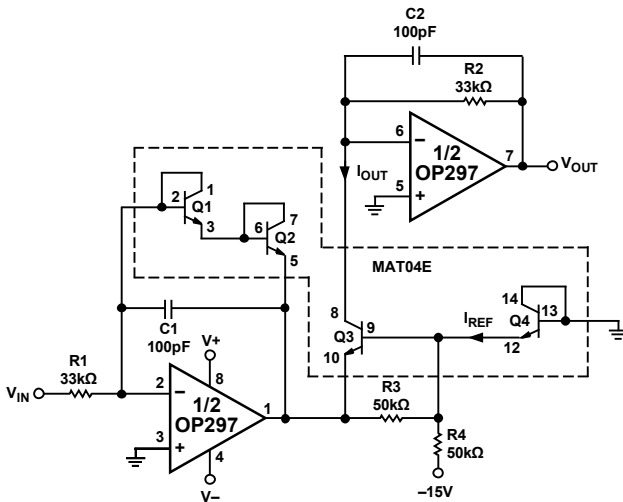

Figure 35. Squaring Amplifier

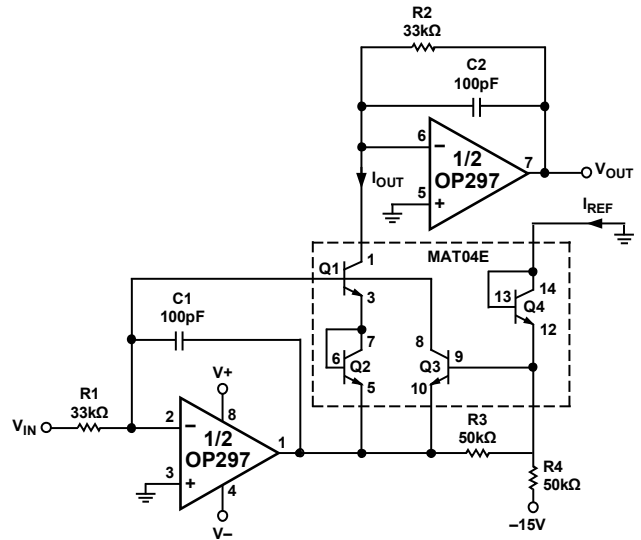

Figure 36. Square Root Amplifier

In these circuits, I_{REF} is a function of the negative power supply. To maintain accuracy, the negative supply should be well regulated. For applications where very high accuracy is required, a voltage reference can be used to set I_{REF} .

An important consideration for the squaring circuit is that a sufficiently large input voltage can force the output beyond the operating range of the output op amp. Resistor R4 can be changed to scale I_{REF} or R1; R2 can be varied to keep the output voltage within the usable range.

Unadjusted accuracy of the square root circuit is better than 0.1% over an input voltage range of 100 mV to 10 V. For a similar input voltage range, the accuracy of the squaring circuit is better than 0.5%.

OUTLINE DIMENSIONS

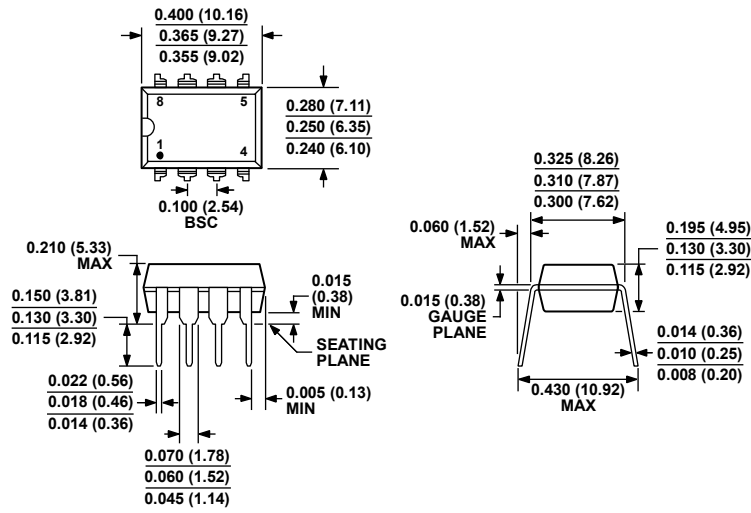

COMPLIANT TO JEDEC STANDARDS MS-001
 CONTROLLING DIMENSIONS ARE IN INCHES; MILLIMETER DIMENSIONS (IN PARENTHESES) ARE ROUNDED-OFF INCH EQUIVALENTS FOR REFERENCE ONLY AND ARE NOT APPROPRIATE FOR USE IN DESIGN. CORNER LEADS MAY BE CONFIGURED AS WHOLE OR HALF LEADS.

Figure 37. 8-Lead Plastic Dual In-Line Package [PDIP]
 P-Suffix (N-8)

Dimensions shown in inches and (millimeters)

070606-A

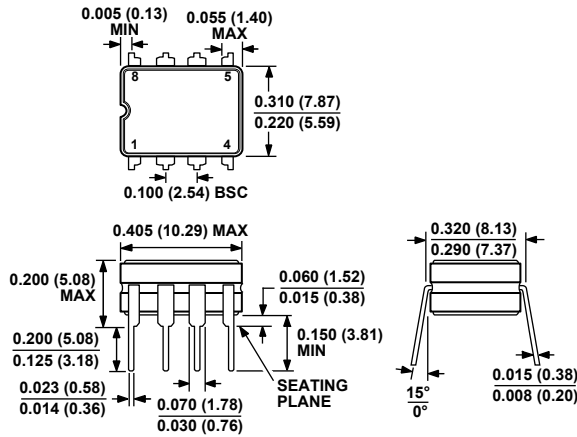

CONTROLLING DIMENSIONS ARE IN INCHES; MILLIMETER DIMENSIONS (IN PARENTHESES) ARE ROUNDED-OFF INCH EQUIVALENTS FOR REFERENCE ONLY AND ARE NOT APPROPRIATE FOR USE IN DESIGN.

Figure 38. 8-Lead Ceramic Dual In-Line Package [CERDIP]
 Z-Suffix (Q-8)

Dimensions shown in inches and (millimeters)

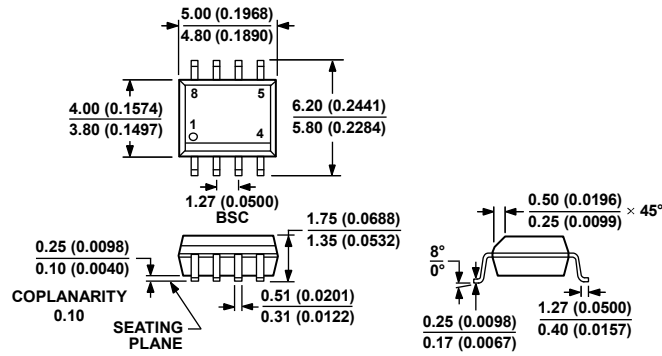

COMPLIANT TO JEDEC STANDARDS MS-012-AA
 CONTROLLING DIMENSIONS ARE IN MILLIMETERS; INCH DIMENSIONS
 (IN PARENTHESES) ARE ROUNDED-OFF MILLIMETER EQUIVALENTS FOR
 REFERENCE ONLY AND ARE NOT APPROPRIATE FOR USE IN DESIGN.

012407-A

Figure 39. 8-Lead Standard Small Outline Package [SOIC_N]
 Narrow Body
 S-Suffix (R-8)
 Dimensions shown in millimeters and (inches)

ORDERING GUIDE

Model	Temperature Range	Package Description	Package Options
OP297EZ	-40°C to +85°C	8-Lead CERDIP	Q-8 (Z-Suffix)
OP297FP	-40°C to +85°C	8-Lead PDIP	N-8 (P-Suffix)
OP297FPZ ¹	-40°C to +85°C	8-Lead PDIP	N-8 (P-Suffix)
OP297FS	-40°C to +85°C	8-Lead SOIC_N	R-8 (S-Suffix)
OP297FS-REEL	-40°C to +85°C	8-Lead SOIC_N	R-8 (S-Suffix)
OP297FS-REEL7	-40°C to +85°C	8-Lead SOIC_N	R-8 (S-Suffix)
OP297FSZ ¹	-40°C to +85°C	8-Lead SOIC_N	R-8 (S-Suffix)
OP297FSZ-REEL ¹	-40°C to +85°C	8-Lead SOIC_N	R-8 (S-Suffix)
OP297FSZ-REEL7 ¹	-40°C to +85°C	8-Lead SOIC_N	R-8 (S-Suffix)
OP297GP	-40°C to +85°C	8-Lead PDIP	N-8 (P-Suffix)
OP297GPZ ¹	-40°C to +85°C	8-Lead PDIP	N-8 (P-Suffix)
OP297GS	-40°C to +85°C	8-Lead SOIC_N	R-8 (S-Suffix)
OP297GS-REEL	-40°C to +85°C	8-Lead SOIC_N	R-8 (S-Suffix)
OP297GS-REEL7	-40°C to +85°C	8-Lead SOIC_N	R-8 (S-Suffix)
OP297GSZ ¹	-40°C to +85°C	8-Lead SOIC_N	R-8 (S-Suffix)
OP297GSZ-REEL ¹	-40°C to +85°C	8-Lead SOIC_N	R-8 (S-Suffix)
OP297GSZ-REEL7 ¹	-40°C to +85°C	8-Lead SOIC_N	R-8 (S-Suffix)

¹ Z = RoHS Compliant Part.

NOTES

OP297

NOTES

Looking for pricing, stock, or lifecycle information?

Click below to explore more details on WIN SOURCE:

 [View OP297GSZ on WIN SOURCE](#)

 [Analog Devices Inc. Information](#)

Optimize Your Supply Chain with WIN SOURCE Solutions

-  Global Sourcing Solution
-  Obsolete Management
-  Cost Control Management
-  Shortage Management
-  Alternative Solution
-  Excess Inventory Management