



**THE DATASHEET OF  
MT8870DN**



**Features**

October 2006

- Complete DTMF Receiver
- Low power consumption
- Internal gain setting amplifier
- Adjustable guard time
- Central office quality
- Power-down mode
- Inhibit mode
- Backward compatible with MT8870C/MT8870C-1

**Applications**

- Receiver system for British Telecom (BT) or CEPT Spec (MT8870D-1)
- Paging systems
- Repeater systems/mobile radio
- Credit card systems
- Remote control
- Personal computers
- Telephone answering machine

**Ordering Information**

MT8870DE	18 Pin PDIP	Tubes
MT8870DS	18 Pin SOIC	Tubes
MT8870DN	20 Pin SSOP	Tubes
MT8870DSR	18 Pin SOIC	Tape & Reel
MT8870DNR	20 Pin SSOP	Tape & Reel
MT8870DN1	20 Pin SSOP*	Tubes
MT8870DE1	18 Pin PDIP*	Tubes
MT8870DS1	18 Pin SOIC*	Tubes
MT8870DNR1	20 Pin SSOP*	Tape & Reel
MT8870DSR1	18 Pin SOIC*	Tape & Reel
MT8870DE1-1	18 Pin PDIP*	Tubes
MT8870DS1-1	18 Pin SOIC*	Tubes
MT8870DSR1-1	18 Pin SOIC*	Tape & Reel

\*Pb Free Matte Tin

-40°C to +85°C

**Description**

The MT8870D/MT8870D-1 is a complete DTMF receiver integrating both the bandsplit filter and digital decoder functions. The filter section uses switched capacitor techniques for high and low group filters; the decoder uses digital counting techniques to detect and decode all 16 DTMF tone-pairs into a 4-bit code.

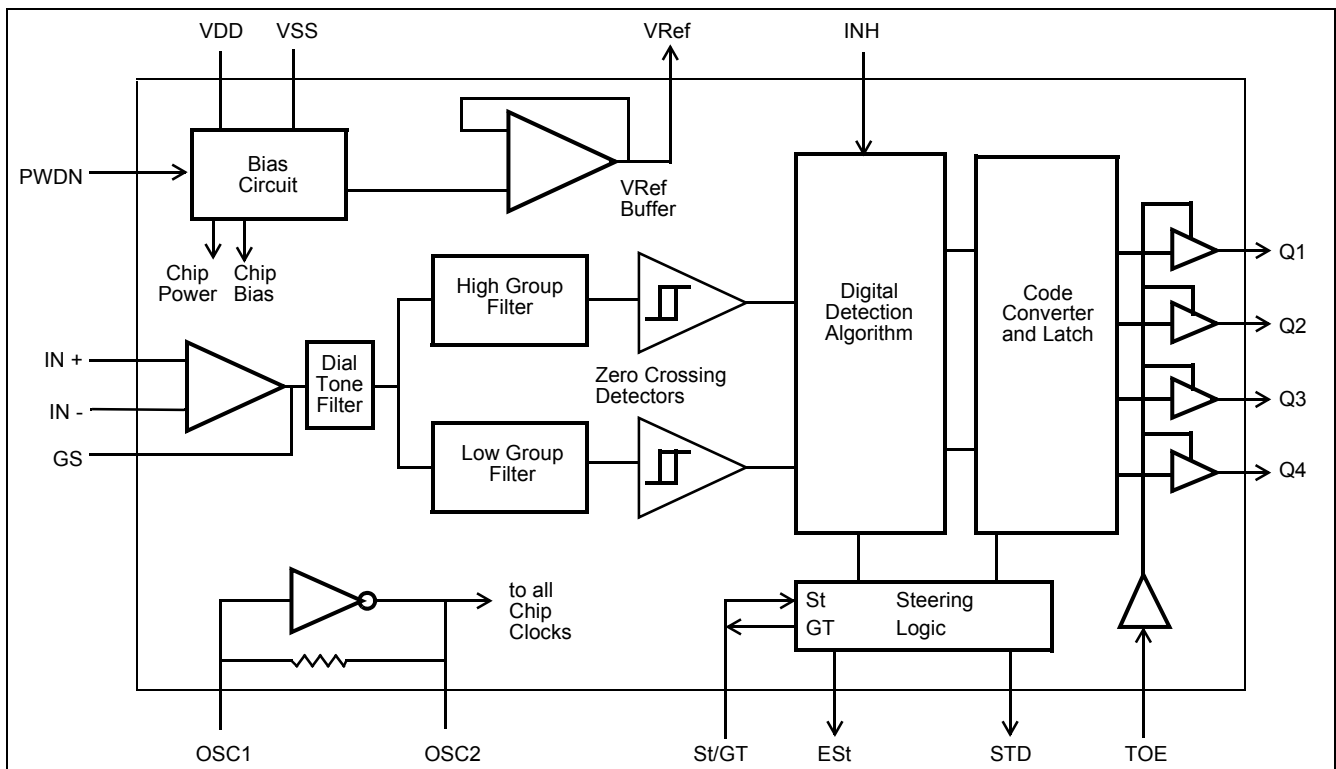
**Figure 1 - Functional Block Diagram**

External component count is minimized by on chip provision of a differential input amplifier, clock oscillator and latched three-state bus interface.

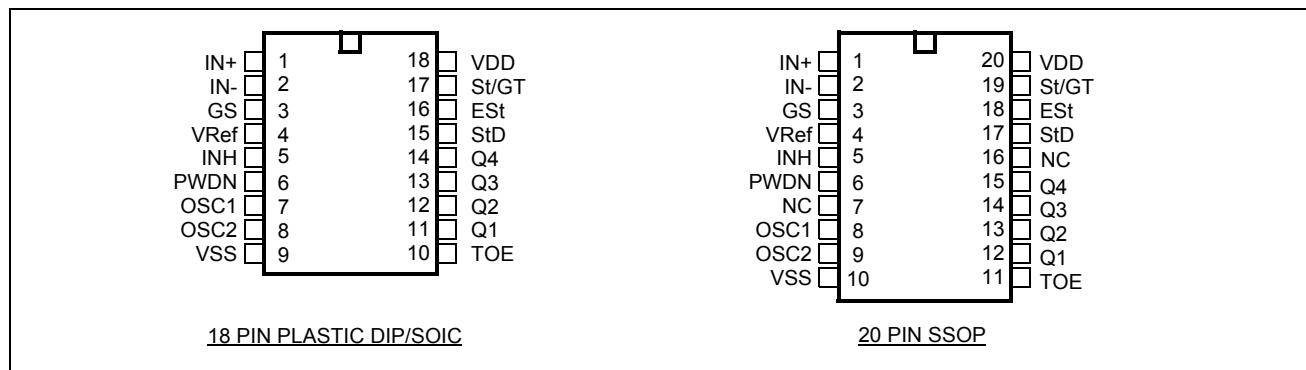

Figure 2 - Pin Connections

Pin Description

Pin #		Name	Description
18	20		
1	1	IN+	<b>Non-Inverting Op-Amp (Input).</b>
2	2	IN-	<b>Inverting Op-Amp (Input).</b>
3	3	GS	<b>Gain Select.</b> Gives access to output of front end differential amplifier for connection of feedback resistor.
4	4	V <sub>Ref</sub>	<b>Reference Voltage (Output).</b> Nominally V <sub>DD</sub> /2 is used to bias inputs at mid-rail (see Fig. 6 and Fig. 10).
5	5	INH	<b>Inhibit (Input).</b> Logic high inhibits the detection of tones representing characters A, B, C and D. This pin input is internally pulled down.
6	6	PWDN	<b>Power Down (Input).</b> Active high. Powers down the device and inhibits the oscillator. This pin input is internally pulled down.
7	8	OSC1	<b>Clock (Input).</b>
8	9	OSC2	<b>Clock (Output).</b> A 3.579545 MHz crystal connected between pins OSC1 and OSC2 completes the internal oscillator circuit.
9	10	V <sub>SS</sub>	<b>Ground (Input).</b> 0 V typical.
10	11	TOE	<b>Three State Output Enable (Input).</b> Logic high enables the outputs Q1-Q4. This pin is pulled up internally.
11-14	12-15	Q1-Q4	<b>Three State Data (Output).</b> When enabled by TOE, provide the code corresponding to the last valid tone-pair received (see Table 1). When TOE is logic low, the data outputs are high impedance.
15	17	StD	<b>Delayed Steering (Output).</b> Presents a logic high when a received tone-pair has been registered and the output latch updated; returns to logic low when the voltage on St/GT falls below V <sub>TSt</sub> .
16	18	ESt	<b>Early Steering (Output).</b> Presents a logic high once the digital algorithm has detected a valid tone pair (signal condition). Any momentary loss of signal condition will cause ESt to return to a logic low.

**Pin Description**

Pin #		Name	Description
18	20		
17	19	St/GT	<b>Steering Input/Guard time (Output) Bidirectional.</b> A voltage greater than $V_{TSt}$ detected at St causes the device to register the detected tone pair and update the output latch. A voltage less than $V_{TSt}$ frees the device to accept a new tone pair. The GT output acts to reset the external steering time-constant; its state is a function of ESt and the voltage on St.
18	20	$V_{DD}$	<b>Positive power supply (Input).</b> +5 V typical.
	7, 16	NC	No Connection.

**Functional Description**

The MT8870D/MT8870D-1 monolithic DTMF receiver offers small size, low power consumption and high performance. Its architecture consists of a bandsplit filter section, which separates the high and low group tones, followed by a digital counting section which verifies the frequency and duration of the received tones before passing the corresponding code to the output bus.

**Filter Section**

Separation of the low-group and high group tones is achieved by applying the DTMF signal to the inputs of two sixth-order switched capacitor bandpass filters, the bandwidths of which correspond to the low and high group frequencies. The filter section also incorporates notches at 350 and 440 Hz for exceptional dial tone rejection (see Figure 3). Each filter output is followed by a single order switched capacitor filter section which smooths the signals prior to limiting. Limiting is performed by high-gain comparators which are provided with hysteresis to prevent detection of unwanted low-level signals. The outputs of the comparators provide full rail logic swings at the frequencies of the incoming DTMF signals.

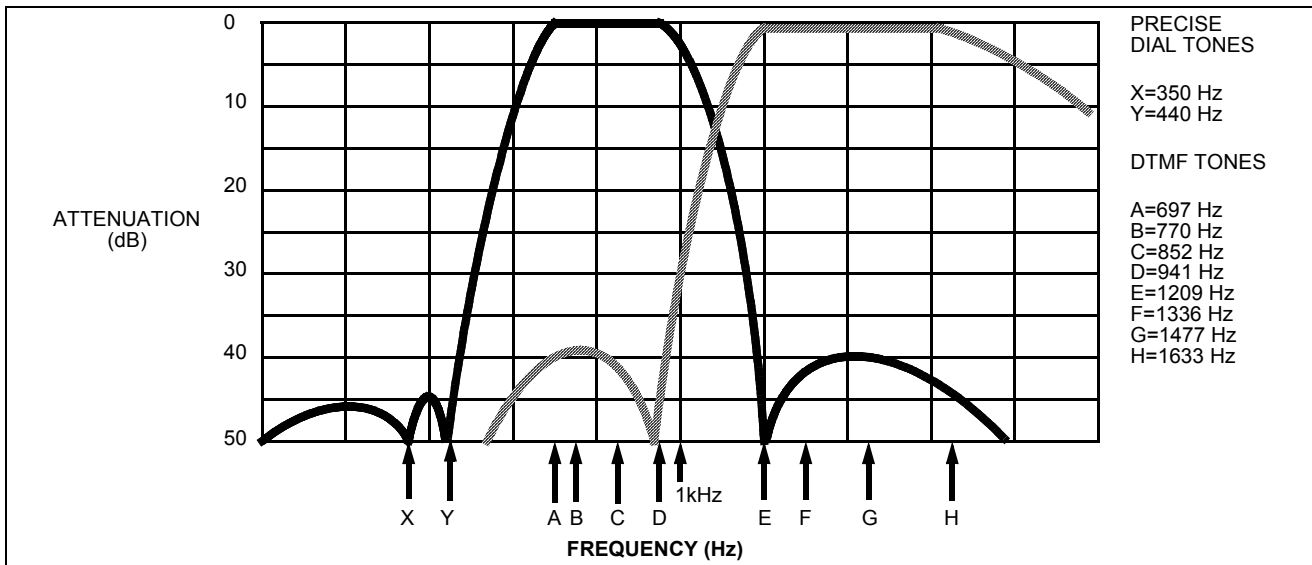

**Figure 3 - Filter Response**

**Decoder Section**

Following the filter section is a decoder employing digital counting techniques to determine the frequencies of the incoming tones and to verify that they correspond to standard DTMF frequencies. A complex averaging algorithm protects against tone simulation by extraneous signals such as voice while providing tolerance to small frequency deviations and variations. This averaging algorithm has been developed to ensure an optimum combination of immunity to talk-off and tolerance to the presence of interfering frequencies (third tones) and noise. When the detector recognizes the presence of two valid tones (this is referred to as the “signal condition” in some industry specifications) the “Early Steering” (ESt) output will go to an active state. Any subsequent loss of signal condition will cause ESt to assume an inactive state (see “Steering Circuit”).

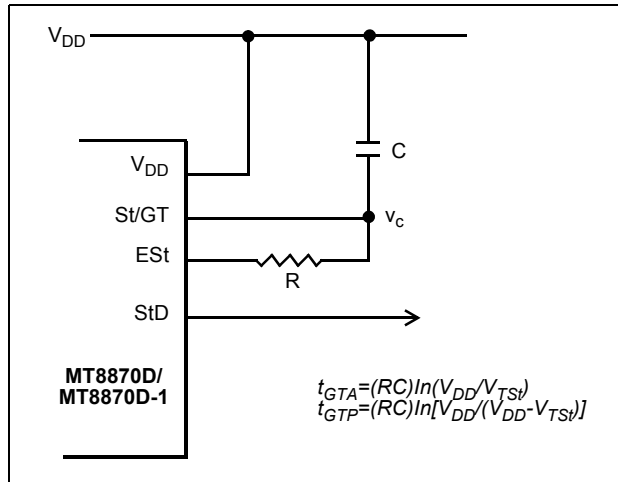

**Figure 4 - Basic Steering Circuit**

**Steering Circuit**

Before registration of a decoded tone pair, the receiver checks for a valid signal duration (referred to as character recognition condition). This check is performed by an external RC time constant driven by ESt. A logic high on ESt causes v<sub>c</sub> (see Figure 4) to rise as the capacitor discharges. Provided signal condition is maintained (ESt remains high) for the validation period (t<sub>GTP</sub>), v<sub>c</sub> reaches the threshold (V<sub>TSI</sub>) of the steering logic to register the tone pair, latching its corresponding 4-bit code (see Table 1) into the output latch. At this point the GT output is activated and drives v<sub>c</sub> to V<sub>DD</sub>. GT continues to drive high as long as ESt remains high. Finally, after a short delay to allow the output latch to settle, the delayed steering output flag (StD) goes high, signalling that a received tone pair has been registered. The contents of the output latch are made available on the 4-bit output bus by raising the three state control input (TOE) to a logic high. The steering circuit works in reverse to validate the interdigit pause between signals. Thus, as well as rejecting signals too short to be considered valid, the receiver will tolerate signal interruptions (dropout) too short to be considered a valid pause. This facility, together with the capability of selecting the steering time constants externally, allows the designer to tailor performance to meet a wide variety of system requirements.

**Guard Time Adjustment**

In many situations not requiring selection of tone duration and interdigital pause, the simple steering circuit shown in Figure 4 is applicable. Component values are chosen according to the formula:

$$t_{REC} = t_{DP} + t_{GTP}$$

$$t_{ID} = t_{DA} + t_{GTA}$$

The value of  $t_{DP}$  is a device parameter (see Figure 11) and  $t_{REC}$  is the minimum signal duration to be recognized by the receiver. A value for C of 0.1  $\mu$ F is recommended for most applications, leaving R to be selected by the designer.

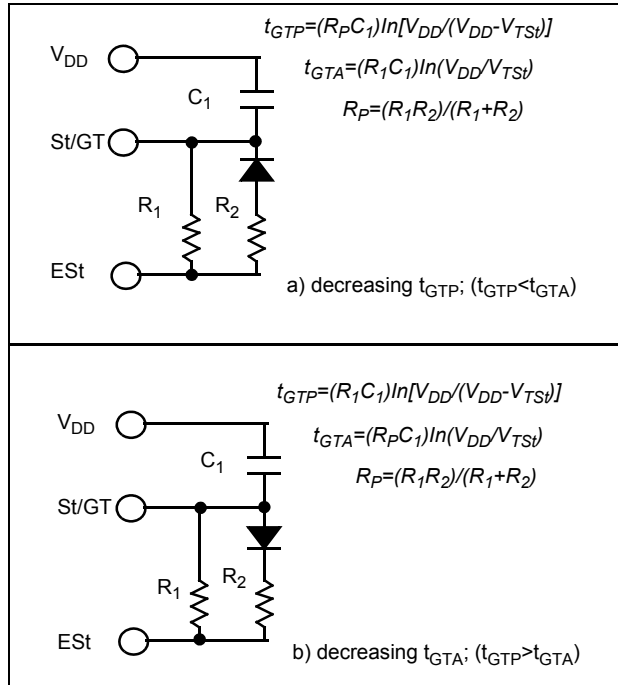

Figure 5 - Guard Time Adjustment

Digit	TOE	INH	Est	Q <sub>4</sub>	Q <sub>3</sub>	Q <sub>2</sub>	Q <sub>1</sub>
ANY	L	X	H	Z	Z	Z	Z
1	H	X	H	0	0	0	1
2	H	X	H	0	0	1	0
3	H	X	H	0	0	1	1
4	H	X	H	0	1	0	0
5	H	X	H	0	1	0	1
6	H	X	H	0	1	1	0
7	H	X	H	0	1	1	1
8	H	X	H	1	0	0	0
9	H	X	H	1	0	0	1
0	H	X	H	1	0	1	0
*	H	X	H	1	0	1	1
#	H	X	H	1	1	0	0
A	H	L	H	1	1	0	1
B	H	L	H	1	1	1	0
C	H	L	H	1	1	1	1
D	H	L	H	0	0	0	0
A	H	H	L	undetected, the output code will remain the same as the previous detected code			
B	H	H	L				
C	H	H	L				
D	H	H	L				

Table 1 - Functional Decode Table

L=LOGIC LOW, H=LOGIC HIGH, Z=HIGH IMPEDANCE  
X = DON'T CARE

Different steering arrangements may be used to select independently the guard times for tone present ( $t_{GTP}$ ) and tone absent ( $t_{GTA}$ ). This may be necessary to meet system specifications which place both accept and reject limits on both tone duration and interdigital pause. Guard time adjustment also allows the designer to tailor system parameters such as talk off and noise immunity. Increasing  $t_{REC}$  improves talk-off performance since it reduces the probability that tones simulated by speech will maintain signal condition long enough to be registered. Alternatively, a relatively short  $t_{REC}$  with a long  $t_{DO}$  would be appropriate for extremely noisy environments where fast acquisition time and immunity to tone drop-outs are required. Design information for guard time adjustment is shown in Figure 5.

### Power-down and Inhibit Mode

A logic high applied to pin 6 (PWDN) will power down the device to minimize the power consumption in a standby mode. It stops the oscillator and the functions of the filters.

Inhibit mode is enabled by a logic high input to the pin 5 (INH). It inhibits the detection of tones representing characters A, B, C, and D. The output code will remain the same as the previous detected code (see Table 1).

### Differential Input Configuration

The input arrangement of the MT8870D/MT8870D-1 provides a differential-input operational amplifier as well as a bias source ( $V_{Ref}$ ) which is used to bias the inputs at mid-rail. Provision is made for connection of a feedback resistor to the op-amp output (GS) for adjustment of gain. In a single-ended configuration, the input pins are connected as shown in Figure 10 with the op-amp connected for unity gain and  $V_{Ref}$  biasing the input at  $\frac{1}{2}V_{DD}$ . Figure 6 shows the differential configuration, which permits the adjustment of gain with the feedback resistor  $R_5$ .

### Crystal Oscillator

The internal clock circuit is completed with the addition of an external 3.579545 MHz crystal and is normally connected as shown in Figure 10 (Single-Ended Input Configuration). However, it is possible to configure several MT8870D/MT8870D-1 devices employing only a single oscillator crystal. The oscillator output of the first device in the chain is coupled through a 30 pF capacitor to the oscillator input (OSC1) of the next device. Subsequent devices are connected in a similar fashion. Refer to Figure 7 for details. The problems associated with unbalanced loading are not a concern with the arrangement shown, i.e., precision balancing capacitors are not required.

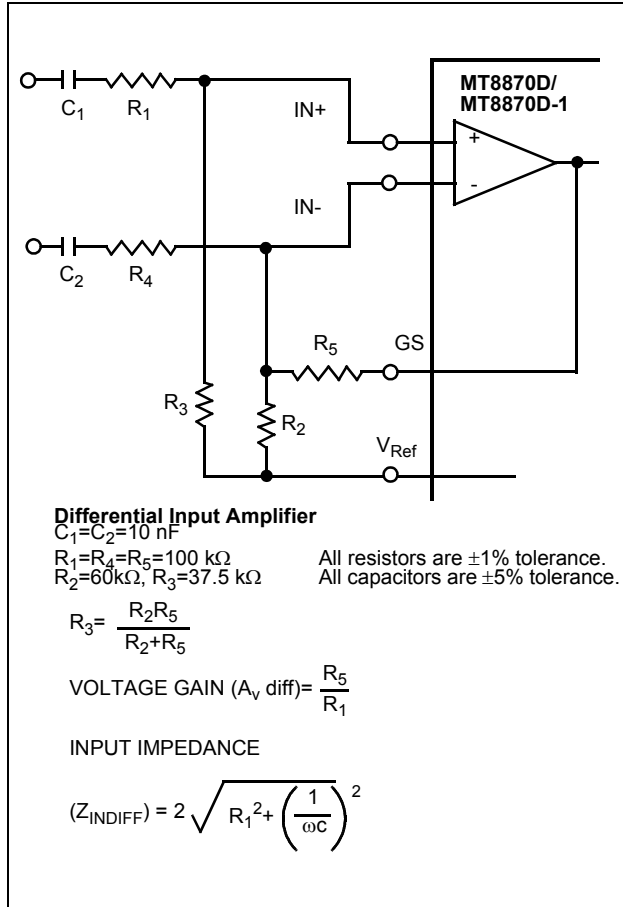

Figure 6 - Differential Input Configuration

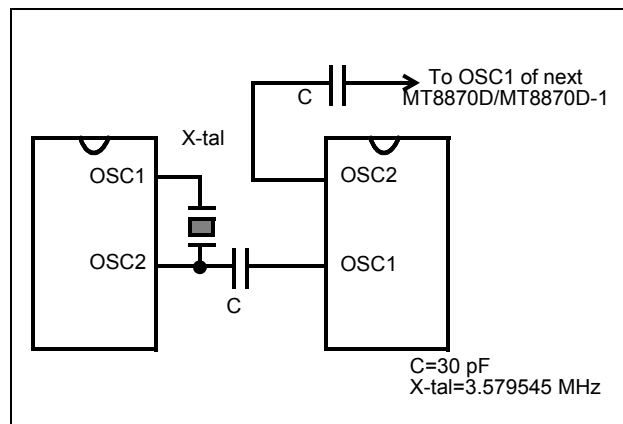

Figure 7 - Oscillator Connection

Parameter	Unit	Resonator
R1	Ohms	10.752
L1	mH	.432
C1	pF	4.984
C0	pF	37.915
Qm	-	896.37
Δf	%	±0.2%

**Table 2 - Recommended Resonator Specifications**

Note: Qm=quality factor of RLC model, i.e.,  $1/2\pi fR1C1$ .

## Applications

### Receiver System for British Telecom Spec POR 1151

The circuit shown in Fig. 9 illustrates the use of MT8870D-1 device in a typical receiver system. BT Spec defines the input signals less than -34 dBm as the non-operate level. This condition can be attained by choosing a suitable values of R<sub>1</sub> and R<sub>2</sub> to provide 3 dB attenuation, such that -34 dBm input signal will correspond to -37 dBm at the gain setting pin GS of MT8870D-1. As shown in the diagram, the component values of R<sub>3</sub> and C<sub>2</sub> are the guard time requirements when the total component tolerance is 6%. For better performance, it is recommended to use the non-symmetric guard time circuit in Fig. 8.

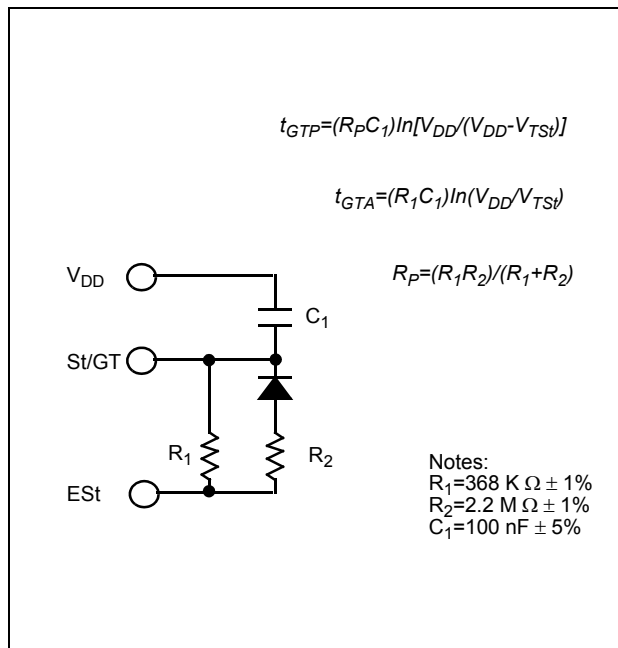

**Figure 8 - Non-Symmetric Guard Time Circuit**

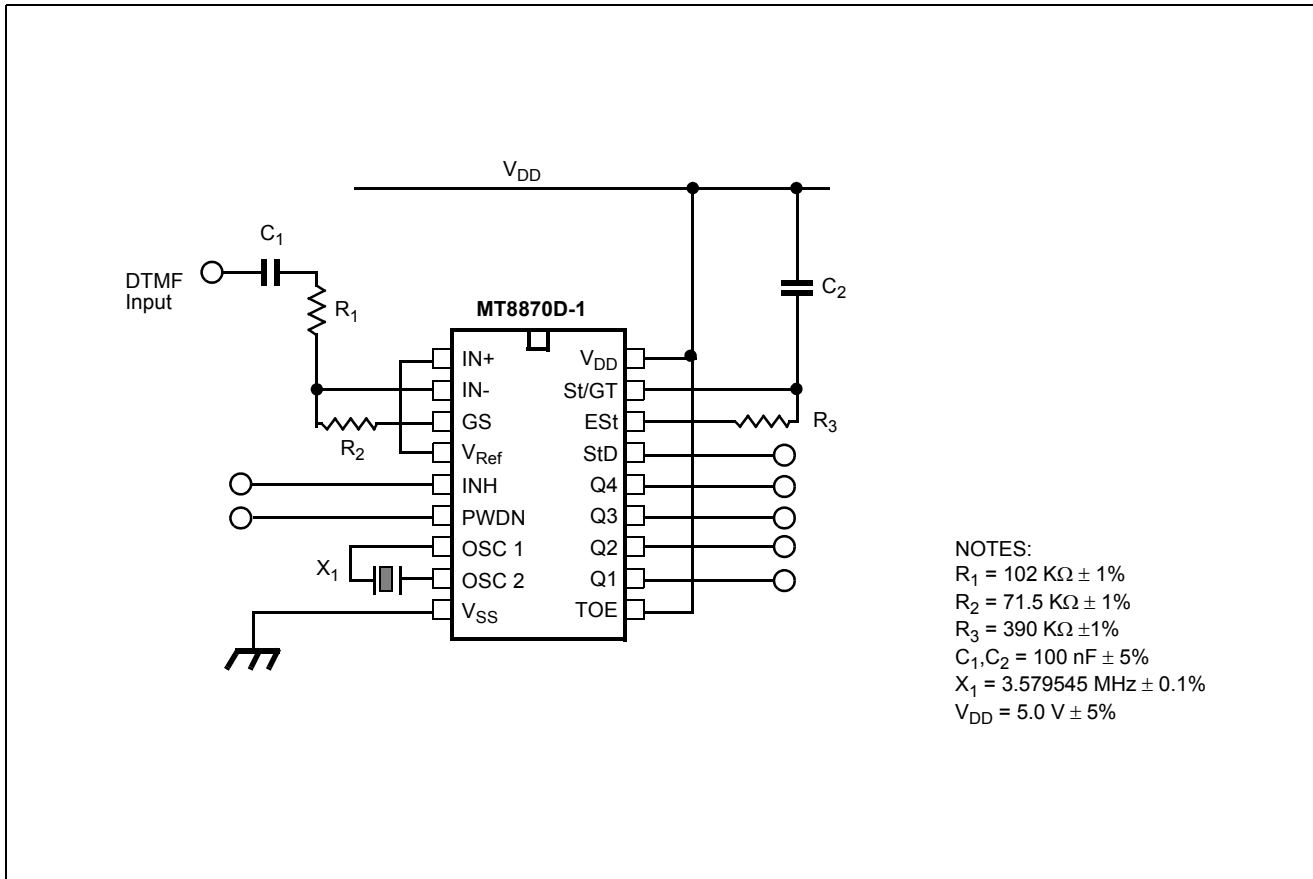

Figure 9 - Single-Ended Input Configuration for BT or CEPT Spec

**Absolute Maximum Ratings**<sup>†</sup>

	Parameter	Symbol	Min.	Max.	Units
1	DC Power Supply Voltage	$V_{DD}$		7	V
2	Voltage on any pin	$V_I$	$V_{SS}-0.3$	$V_{DD}+0.3$	V
3	Current at any pin (other than supply)	$I_I$		10	mA
4	Storage temperature	$T_{STG}$	-65	+150	°C
5	Package power dissipation	$P_D$		500	mW

<sup>†</sup> Exceeding these values may cause permanent damage. Functional operation under these conditions is not implied. Derate above 75°C at 16 mW / °C. All leads soldered to board.

**Recommended Operating Conditions** - Voltages are with respect to ground ( $V_{SS}$ ) unless otherwise stated.

	Parameter	Sym.	Min.	Typ. <sup>‡</sup>	Max.	Units	Test Conditions
1	DC Power Supply Voltage	$V_{DD}$	4.75	5.0	5.25	V	
2	Operating Temperature	$T_O$	-40		+85	°C	
3	Crystal/Clock Frequency	fc		3.579545		MHz	
4	Crystal/Clock Freq.Tolerance	$\Delta fc$		$\pm 0.1$		%	

<sup>‡</sup> Typical figures are at 25°C and are for design aid only: not guaranteed and not subject to production testing.

**DC Electrical Characteristics** -  $V_{DD}=5.0V \pm 5\%$ ,  $V_{SS}=0V$ ,  $-40^\circ C \leq T_O \leq +85^\circ C$ , unless otherwise stated.

		Characteristics	Sym.	Min.	Typ. <sup>‡</sup>	Max.	Units	Test Conditions
1	S U P P L Y	Standby supply current	$I_{DDQ}$		10	25	$\mu A$	PWDN= $V_{DD}$
2		Operating supply current	$I_{DD}$		3.0	9.0	mA	
3		Power consumption	$P_O$		15		mW	fc=3.579545 MHz
4	I N P U T S	High level input	$V_{IH}$	3.5			V	$V_{DD}=5.0 V$
5		Low level input voltage	$V_{IL}$			1.5	V	$V_{DD}=5.0 V$
6		Input leakage current	$I_{IH}/I_{IL}$		0.1		$\mu A$	$V_{IN}=V_{SS}$ or $V_{DD}$
7		Pull up (source) current	$I_{SO}$		7.5	20	$\mu A$	TOE (pin 10)=0, $V_{DD}=5.0 V$
8		Pull down (sink) current	$I_{SI}$		15	45	$\mu A$	INH=5.0 V, PWDN=5.0 V, $V_{DD}=5.0 V$
9		Input impedance (IN+, IN-)	$R_{IN}$		10		$M\Omega$	@ 1 kHz
10		Steering threshold voltage	$V_{TSt}$	2.2	2.4	2.5	V	$V_{DD} = 5.0 V$

**DC Electrical Characteristics** -  $V_{DD}=5.0V \pm 5\%$ ,  $V_{SS}=0V$ ,  $-40^{\circ}C \leq T_O \leq +85^{\circ}C$ , unless otherwise stated.

		Characteristics	Sym.	Min.	Typ. <sup>‡</sup>	Max.	Units	Test Conditions
11	O U T P U T S	Low level output voltage	$V_{OL}$			$V_{SS}+0.03$	V	No load
12		High level output voltage	$V_{OH}$	$V_{DD}-0.03$			V	No load
13		Output low (sink) current	$I_{OL}$	1.0	2.5		mA	$V_{OUT}=0.4V$
14		Output high (source) current	$I_{OH}$	0.4	0.8		mA	$V_{OUT}=4.6V$
15		$V_{Ref}$ output voltage	$V_{Ref}$	2.3	2.5	2.7	V	No load, $V_{DD} = 5.0V$
16		$V_{Ref}$ output resistance	$R_{OR}$		1		k $\Omega$	

<sup>‡</sup> Typical figures are at 25°C and are for design aid only: not guaranteed and not subject to production testing.

**Operating Characteristics** -  $V_{DD}=5.0V \pm 5\%$ ,  $V_{SS}=0V$ ,  $-40^{\circ}C \leq T_O \leq +85^{\circ}C$ , unless otherwise stated.**Gain Setting Amplifier**

	Characteristics	Sym.	Min.	Typ. <sup>‡</sup>	Max.	Units	Test Conditions
1	Input leakage current	$I_{IN}$			100	nA	$V_{SS} \leq V_{IN} \leq V_{DD}$
2	Input resistance	$R_{IN}$	10			M $\Omega$	
3	Input offset voltage	$V_{OS}$			25	mV	
4	Power supply rejection	PSRR	50			dB	1 kHz
5	Common mode rejection	CMRR	40			dB	$0.75V \leq V_{IN} \leq 4.25V$ biased at $V_{Ref}=2.5V$
6	DC open loop voltage gain	$A_{VOL}$	32			dB	
7	Unity gain bandwidth	$f_C$	0.30			MHz	
8	Output voltage swing	$V_O$	4.0			$V_{pp}$	Load $\geq 100k\Omega$ to $V_{SS}$ @ GS
9	Maximum capacitive load (GS)	$C_L$			100	pF	
10	Resistive load (GS)	$R_L$			50	k $\Omega$	
11	Common mode range	$V_{CM}$	2.5			$V_{pp}$	No Load

**MT8870D AC Electrical Characteristics** - $V_{DD}=5.0V \pm 5\%$ ,  $V_{SS}=0V$ ,  $-40^{\circ}C \leq T_O \leq +85^{\circ}C$ , using Test Circuit shown in Figure 10.

	Characteristics	Sym.	Min.	Typ. <sup>‡</sup>	Max.	Units	Notes*
1	Valid input signal levels (each tone of composite signal)		-29		+1	dBm	1,2,3,5,6,9
			27.5		869	mV <sub>RMS</sub>	1,2,3,5,6,9
2	Negative twist accept				8	dB	2,3,6,9,12
3	Positive twist accept				8	dB	2,3,6,9,12
4	Frequency deviation accept		$\pm 1.5\% \pm 2$ Hz				2,3,5,9
5	Frequency deviation reject		$\pm 3.5\%$				2,3,5,9
6	Third tone tolerance			-16		dB	2,3,4,5,9,10
7	Noise tolerance			-12		dB	2,3,4,5,7,9,10
8	Dial tone tolerance			+22		dB	2,3,4,5,8,9,11

<sup>‡</sup> Typical figures are at 25°C and are for design aid only: not guaranteed and not subject to production testing.

**\*NOTES**

1. dBm= decibels above or below a reference power of 1 mW into a 600 ohm load.
2. Digit sequence consists of all DTMF tones.
3. Tone duration= 40 ms, tone pause= 40 ms.
4. Signal condition consists of nominal DTMF frequencies.
5. Both tones in composite signal have an equal amplitude.
6. Tone pair is deviated by  $\pm 1.5\% \pm 2$  Hz.
7. Bandwidth limited (3 kHz) Gaussian noise.
8. The precise dial tone frequencies are (350 Hz and 440 Hz)  $\pm 2\%$ .
9. For an error rate of better than 1 in 10,000.
10. Referenced to lowest level frequency component in DTMF signal.
11. Referenced to the minimum valid accept level.
12. Guaranteed by design and characterization.

**MT8870D-1 AC Electrical Characteristics**  $-V_{DD}=5.0V\pm 5\%$ ,  $V_{SS}=0V$ ,  $-40^{\circ}C \leq T_O \leq +85^{\circ}C$ , using Test Circuit shown in Figure 10.

	Characteristics	Sym.	Min.	Typ. <sup>‡</sup>	Max.	Units	Notes*
1	Valid input signal levels (each tone of composite signal)		-31		+1	dBm	Tested at $V_{DD}=5.0V$ 1,2,3,5,6,9
			21.8		869	mV <sub>RMS</sub>	
2	Input Signal Level Reject		-37			dBm	Tested at $V_{DD}=5.0V$ 1,2,3,5,6,9
			10.9			mV <sub>RMS</sub>	
3	Negative twist accept				8	dB	2,3,6,9,13
4	Positive twist accept				8	dB	2,3,6,9,13
5	Frequency deviation accept		$\pm 1.5\% \pm 2\text{ Hz}$				2,3,5,9
6	Frequency deviation reject		$\pm 3.5\%$				2,3,5,9
7	Third zone tolerance			-18.5		dB	2,3,4,5,9,12
8	Noise tolerance			-12		dB	2,3,4,5,7,9,10
9	Dial tone tolerance			+22		dB	2,3,4,5,8,9,11

<sup>‡</sup> Typical figures are at 25 °C and are for design aid only: not guaranteed and not subject to production testing.

**\*NOTES**

1. dBm= decibels above or below a reference power of 1 mW into a 600 ohm load.
2. Digit sequence consists of all DTMF tones.
3. Tone duration= 40 ms, tone pause= 40 ms.
4. Signal condition consists of nominal DTMF frequencies.
5. Both tones in composite signal have an equal amplitude.
6. Tone pair is deviated by  $\pm 1.5\% \pm 2\text{ Hz}$ .
7. Bandwidth limited (3 kHz) Gaussian noise.
8. The precise dial tone frequencies are (350 Hz and 440 Hz)  $\pm 2\%$ .
9. For an error rate of better than 1 in 10,000.
10. Referenced to lowest level frequency component in DTMF signal.
11. Referenced to the minimum valid accept level.
12. Referenced to Fig. 10 input DTMF tone level at -25dBm (-28dBm at GS Pin) interference frequency range between 480-3400Hz.
13. Guaranteed by design and characterization.

**AC Electrical Characteristics** -  $V_{DD}=5.0V\pm 5\%$ ,  $V_{SS}=0V$ ,  $-40^{\circ}C \leq T_o \leq +85^{\circ}C$ , using Test Circuit shown in Figure 10.

		Characteristics	Sym.	Min.	Typ.‡	Max.	Units	Conditions
1	T I M I N G	Tone present detect time	$t_{DP}$	5	11	14	ms	Note 1
2		Tone absent detect time	$t_{DA}$	0.5	4	8.5	ms	Note 1
3		Tone duration accept	$t_{REC}$			40	ms	Note 2
4		Tone duration reject	$\overline{t_{REC}}$	20			ms	Note 2
5		Interdigit pause accept	$t_{ID}$			40	ms	Note 2
6		Interdigit pause reject	$t_{DO}$	20			ms	Note 2
7	O U T P U T S	Propagation delay (St to Q)	$t_{PQ}$		8	11	$\mu s$	TOE= $V_{DD}$
8		Propagation delay (St to StD)	$t_{PSID}$		12	16	$\mu s$	TOE= $V_{DD}$
9		Output data set up (Q to StD)	$t_{QSiD}$		3.4		$\mu s$	TOE= $V_{DD}$
10		Propagation delay (TOE to Q ENABLE)	$t_{PTE}$		50		ns	load of 10 k $\Omega$ , 50 pF
11		Propagation delay (TOE to Q DISABLE)	$t_{PTD}$		300		ns	load of 10 k $\Omega$ , 50 pF
12	P D W N	Power-up time	$t_{PU}$		30		ms	Note 3
13		Power-down time	$t_{PD}$		20		ms	
14	C L O C K	Crystal/clock frequency	$f_C$	3.575 9	3.579 5	3.583 1	MHz	
15		Clock input rise time	$t_{LHCL}$			110	ns	Ext. clock
16		Clock input fall time	$t_{HLCL}$			110	ns	Ext. clock
17		Clock input duty cycle	DC <sub>CL</sub>	40	50	60	%	Ext. clock
18		Capacitive load (OSC2)	$C_{LO}$			30	pF	

‡ Typical figures are at 25°C and are for design aid only: not guaranteed and not subject to production testing.

**\*NOTES:**

- Used for guard-time calculation purposes only.
- These, user adjustable parameters, are not device specifications. The adjustable settings of these minimums and maximums are recommendations based upon network requirements.
- With valid tone present at input,  $t_{PU}$  equals time from PDWN going low until ESt going high.

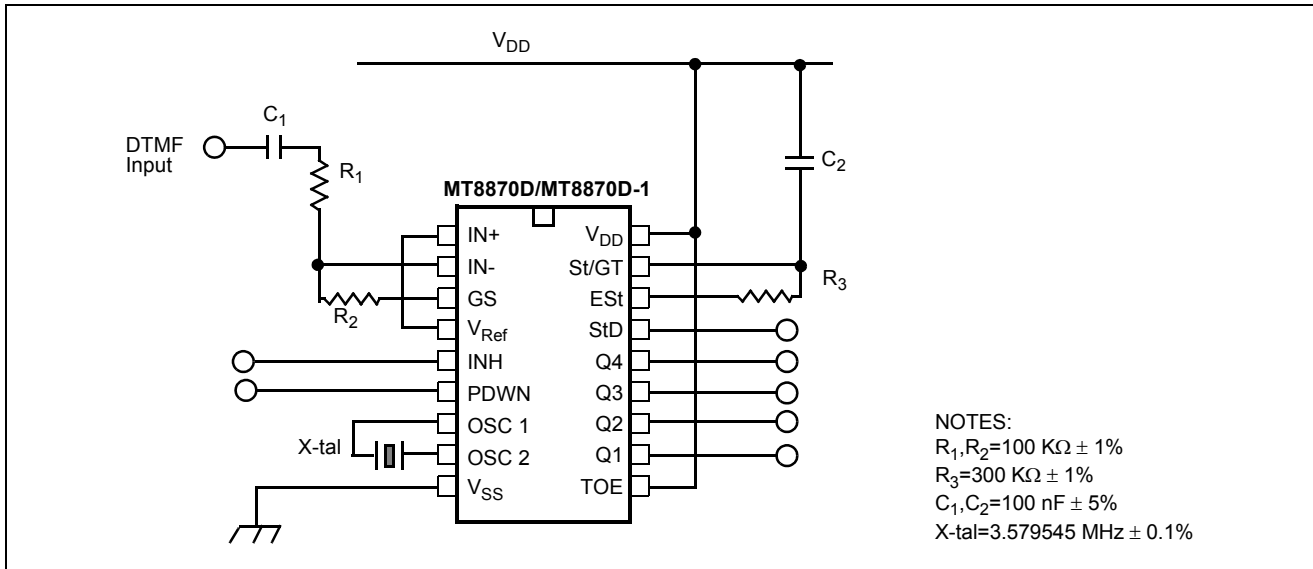

**Figure 10 - Single-Ended Input Configuration**

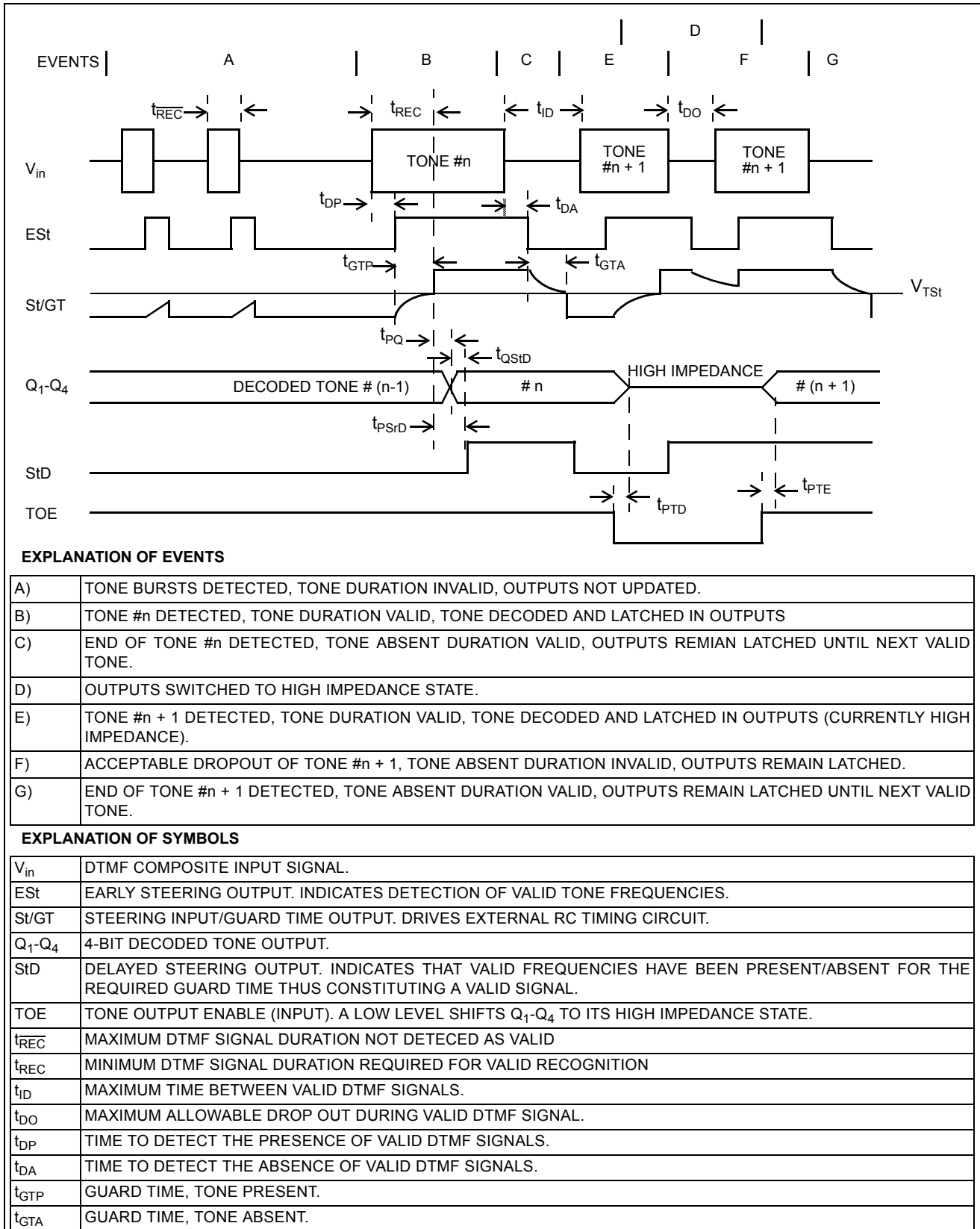
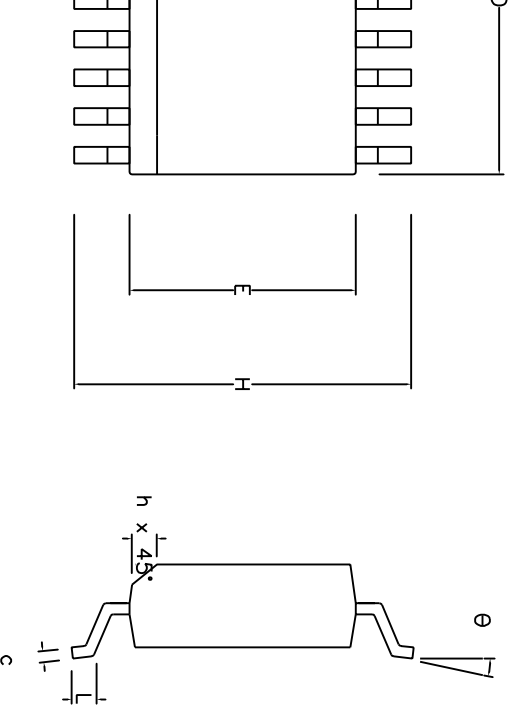
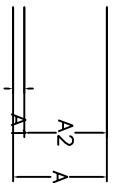

Figure 11 - Timing Diagram



Symbol	Control Dimensions in millimetres			Altern. Dimensions in inches		
	MIN	Nominal	MAX	MIN	Nominal	MAX
A	2.35		2.65	0.093		0.104
A1	0.10		0.30	0.004		0.012
A2	2.25		2.35	0.089		0.092
D	11.35		11.75	0.447		0.463
H	10.00		10.65	0.394		0.419
E	7.40		7.60	0.291		0.299
L	0.40		1.27	0.016		0.050
e	1.27	BSC.		0.050	BSC.	
b	0.33		0.51	0.013		0.020
c	0.23		0.32	0.009		0.013
Ø	0°		8°	0°		8°
h	0.25		0.75	0.010		0.029
N	Pin features 18					
Conforms to JEDEC MS-013AB Iss. C						



Seating Plane

body is optional. If not present, a visual index feature, e.g. a dot, must be located in the lead area.

Lead area dimensions are in millimeters.

Lead include mould flash, protusion or gate burrs. These shall not exceed 0.006" per side.

Body include inter-lead flash or protusion. These shall not exceed 0.010" per side.

Lead include dambar protusion / intrusion. Allowable dambar protusion shall be 0.004" total.



Previous package codes

MP / S

Package Code DC

Package Outline for  
18 lead SOIC  
(0.300" Body Width)

GPDD00014

Symbol	Control Dimensions in millimetres			Altern. Dimensions in inches		
	MIN	Nominal	MAX	MIN	Nominal	MAX
A	1.70		2.00	0.067		0.079
A1	0.05		0.20	0.002		0.008
A2	1.65		1.85	0.065		0.073
D	6.90		7.50	0.272		0.295
E	7.40		8.20	0.291		0.323
E1	5.00		5.60	0.197		0.220
L	0.55		0.95	0.022		0.037
e	0.65 BSC.			0.026 BSC.		
b	0.22		0.38	0.009		0.015
c	0.09		0.25	0.004		0.010
$\theta$	0°		8°	0°		8°
Pin features						
20						
Conforms to JEDEC MO-150 AE Iss. B						

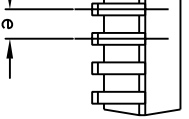
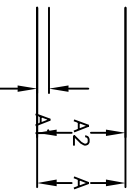
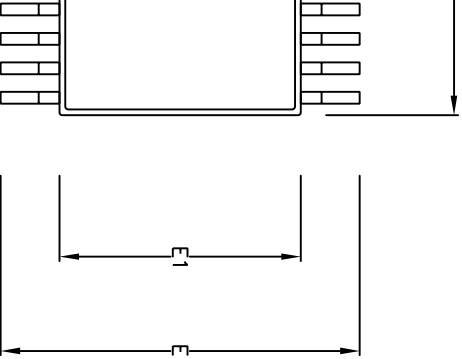
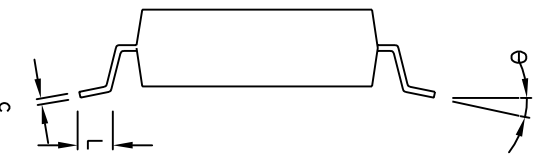

— Seating Plane

This drawing supersedes: –  
418/ED/51481/002 (Swindon/Plymouth)

e, e.g. a dot, must be located within the cross-hatched area.  
are in millimeters.

do not include mould flash or protusion. Mould flash or protusion shall not exceed  
D) and E1 are maximum plastic body size dimensions including mould mismatch.  
not include dambar protusion/intrusion. Allowable dambar protusion shall be 0.13 mm  
dimension. Dambar intrusion shall not reduce dimension b by more than 0.07 mm.

		Previous package codes	Package Code
		NP / N	DD
		Package Outline for 20 lead SSOP (5.3mm Body Width)	
		GPD00294	



**For more information about all Zarlink products  
visit our Web Site at  
[www.zarlink.com](http://www.zarlink.com)**

Information relating to products and services furnished herein by Zarlink Semiconductor Inc. or its subsidiaries (collectively "Zarlink") is believed to be reliable. However, Zarlink assumes no liability for errors that may appear in this publication, or for liability otherwise arising from the application or use of any such information, product or service or for any infringement of patents or other intellectual property rights owned by third parties which may result from such application or use. Neither the supply of such information or purchase of product or service conveys any license, either express or implied, under patents or other intellectual property rights owned by Zarlink or licensed from third parties by Zarlink, whatsoever. Purchasers of products are also hereby notified that the use of product in certain ways or in combination with Zarlink, or non-Zarlink furnished goods or services may infringe patents or other intellectual property rights owned by Zarlink.

This publication is issued to provide information only and (unless agreed by Zarlink in writing) may not be used, applied or reproduced for any purpose nor form part of any order or contract nor to be regarded as a representation relating to the products or services concerned. The products, their specifications, services and other information appearing in this publication are subject to change by Zarlink without notice. No warranty or guarantee express or implied is made regarding the capability, performance or suitability of any product or service. Information concerning possible methods of use is provided as a guide only and does not constitute any guarantee that such methods of use will be satisfactory in a specific piece of equipment. It is the user's responsibility to fully determine the performance and suitability of any equipment using such information and to ensure that any publication or data used is up to date and has not been superseded. Manufacturing does not necessarily include testing of all functions or parameters. These products are not suitable for use in any medical products whose failure to perform may result in significant injury or death to the user. All products and materials are sold and services provided subject to Zarlink's conditions of sale which are available on request.

Purchase of Zarlink's I2C components conveys a licence under the Philips I2C Patent rights to use these components in and I2C System, provided that the system conforms to the I2C Standard Specification as defined by Philips.

Zarlink, ZL, the Zarlink Semiconductor logo and the Legerity logo and combinations thereof, VoiceEdge, VoicePort, SLAC, ISLIC, ISLAC and VoicePath are trademarks of Zarlink Semiconductor Inc.

**TECHNICAL DOCUMENTATION - NOT FOR RESALE**

---

## Looking for pricing, stock, or lifecycle information?

Click below to explore more details on WIN SOURCE:

- ⊖ [View MT8870DN on WIN SOURCE](#)
- ⊖ [Microsemi Corporation](#) Information

## Optimize Your Supply Chain with WIN SOURCE Solutions

- ✓ Global Sourcing Solution
- ✓ Obsolete Management
- ✓ Cost Control Management
- ✓ Shortage Management
- ✓ Alternative Solution
- ✓ Excess Inventory Management