



**THE DATASHEET OF  
LTC4555EUD#PBF**



## FEATURES

- **SIM Power Supply: 1.8V/3V at 50mA**
- **Input Voltage Range: 3V to 6V**
- **Controller Voltage Range: 1.2V to 4.4V**
- **14kV ESD On All SIM Contact Pins**
- **Meets All ETSI, IMT-2000 and ISO7816 SIM/Smart Card Interface Requirements**
- Level Translators to 1.8V or 3V
- 20 $\mu$ A Operating Current
- Logic-Controlled Shutdown ( $I_{SD} < 1\mu$ A)
- Available in a Low Profile, 16-Pin (3mm  $\times$  3mm) QFN Package

## APPLICATIONS

- SIM Interface in 3G Cellular Telephones
- Smart Card Readers

## DESCRIPTION

The **LTC<sup>®</sup>4555** provides power conversion and signal level shifting needed for low voltage 2.5G and 3G cellular telephones to interface with 1.8V or 3V subscriber identity modules (SIMs). The part meets all type approval requirements for 1.8V and 3V SIMs and smart cards. The part contains an LDO linear regulator to supply SIM power at either 1.8V or 3V from a 3V to 6V input. The output voltage is selected with a single pin and up to 50mA of load current can be supplied.

Internal level translators allow controllers operating with supplies as low as 1.2V to interface with 1.8V or 3V smart cards. Battery life is maximized by 20 $\mu$ A operating current and <1 $\mu$ A shutdown current. Board area is minimized by the 3mm  $\times$  3mm leadless QFN package.

LT, LT, LTC, LTM, Linear Technology and the Linear Logo are registered trademarks and ThinSOT is a trademark of Linear Technology Corporation. All other trademarks are the property of their respective owners.

## TYPICAL APPLICATION

**Typical SIM Interface**

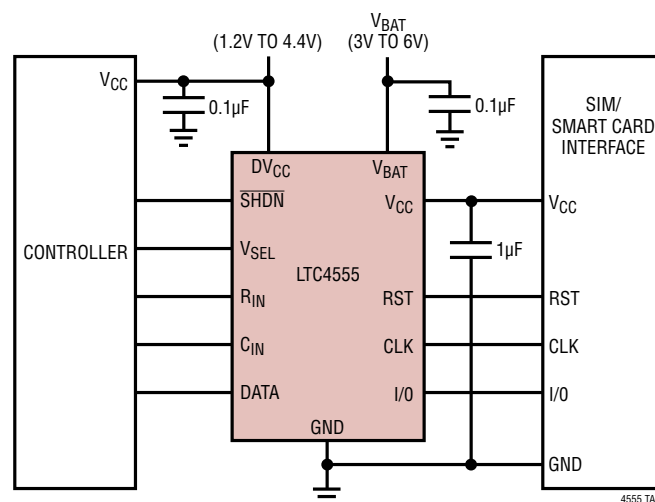

4555 TA01

## ABSOLUTE MAXIMUM RATINGS

(Note 1)

$V_{BAT}$ , $DV_{CC}$ , $V_{CC}$ to GND .....	-0.3V to 6.5V
Digital Inputs to GND .....	-0.3V to 6.5V
CLK, RST, I/O to GND .....	-0.3V to $V_{CC} + 0.3V$
$V_{CC}$ Short-Circuit Duration .....	Infinite
Operating Temperature Range (Note 2)....	-40°C to 85°C
Junction Temperature .....	125°C
Storage Temperature Range.....	-65°C to 125°C

## PIN CONFIGURATION

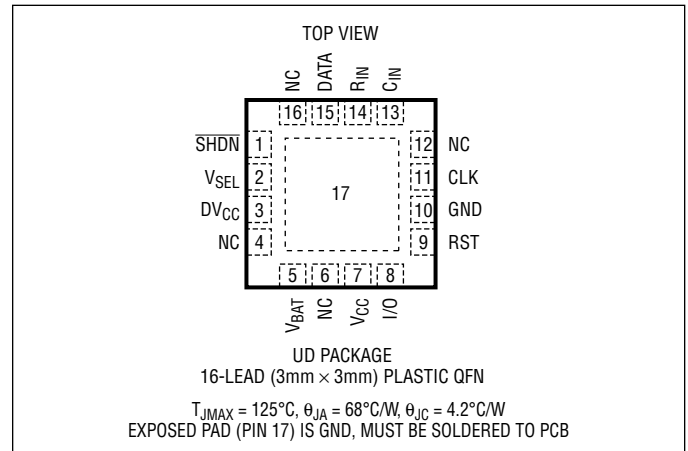

## ORDER INFORMATION <http://www.linear.com/product/LTC4555#orderinfo>

LEAD FREE FINISH	TAPE AND REEL	PART MARKING	PACKAGE DESCRIPTION	TEMPERATURE RANGE
LTC4555EUD#PBF	LTC4555EUD#TRPBF	LAAA	16-Lead (3mm × 3mm) Plastic QFN	-40°C to 85°C

Consult LTC Marketing for parts specified with wider operating temperature ranges.

For more information on lead free part marking, go to: <http://www.linear.com/leadfree/>

For more information on tape and reel specifications, go to: <http://www.linear.com/tapeandreel/>. Some packages are available in 500 unit reels through designated sales channels with #TRMPBF suffix.

## ELECTRICAL CHARACTERISTICS

The ● denotes the specifications which apply over the full operating temperature range, otherwise specifications are at  $T_A = 25^{\circ}\text{C}$ .

PARAMETER	CONDITIONS	MIN	TYP	MAX	UNITS
$V_{BAT}$ Operating Voltage		● 3		6	V
$V_{BAT}$ Operating Current	$I_{CC} = 0\text{mA}$	●	20	30	$\mu\text{A}$
$V_{BAT}$ Shutdown Current	$SHDN = 0V$ , $V_{BAT} = 4.5V$	●		1	$\mu\text{A}$
$DV_{CC}$ Operating Voltage		● 1.2		4.4	V
$DV_{CC}$ Operating Current	$f_{CLK} = 1\text{MHz}$	●	5	10	$\mu\text{A}$
$DV_{CC}$ Shutdown Current	$SHDN = 0V$	●		1	$\mu\text{A}$
$DV_{CC}$ Undervoltage Lockout		● 0.5		1.1	V
$V_{CC}$ Output Voltage	$V_{SEL} = DV_{CC}$ , $V_{BAT} = 3V$ , $I_{VCC} = 50\text{mA}$	●	2.8		V
	$V_{SEL} = DV_{CC}$ , $V_{BAT} = 3.3V$ to $6V$ , $I_{VCC} = 0\text{mA}$ to $50\text{mA}$	●	3.0	3.2	V
	$V_{SEL} = 0$ , $V_{BAT} = 2.6V$ to $6V$ , $I_{VCC} = 0\text{mA}$ to $50\text{mA}$	●	1.7	1.8	1.9
$V_{CC}$ Short-Circuit Current	$V_{CC}$ Shorted to GND	● 60	110	175	mA
<b>Controller Inputs/Outputs</b>					
Input Voltage Range	$SHDN$ , $V_{SEL}$ , $R_{IN}$ , $C_{IN}$ , DATA		0	$DV_{CC}$	V
Input Current ( $I_{IH}/I_{IL}$ )	$SHDN$ , $V_{SEL}$ , $R_{IN}$ , $C_{IN}$	● -100		100	nA
High Input Threshold Voltage ( $V_{IH}$ )	$R_{IN}$ , $C_{IN}$	●		$0.7 \times DV_{CC}$	V
Low Input Threshold Voltage ( $V_{IL}$ )	$R_{IN}$ , $C_{IN}$	●	$0.2 \times DV_{CC}$		V
High Input Threshold Voltage ( $V_{IH}$ )	$SHDN$ , $V_{SEL}$	●		1	V
Low Input Threshold Voltage ( $V_{IL}$ )	$SHDN$ , $V_{SEL}$	●	0.4		V

4555fc

## ELECTRICAL CHARACTERISTICS

The ● denotes the specifications which apply over the full operating temperature range, otherwise specifications are at  $T_A = 25^\circ\text{C}$ .

PARAMETER	CONDITIONS		MIN	TYP	MAX	UNITS
High Level Input Current ( $I_{IH}$ )	DATA	●	-20		20	$\mu\text{A}$
Low Level Input Current ( $I_{IL}$ )	DATA	●			1	$\text{mA}$
High Level Output Voltage ( $V_{OH}$ )	DATA $I_{OH} = 20\mu\text{A}$ , $I/O = V_{CC}$	●	$0.7 \times DV_{CC}$			V
Low Level Output Voltage ( $V_{OL}$ )	DATA $I_{OL} = -200\mu\text{A}$ , $I/O = 0\text{V}$	●			0.4	V
DATA Pull-Up Resistance	Between DATA and $DV_{CC}$		13	20	30	$\text{k}\Omega$
<b>SIM Inputs/Outputs (<math>V_{CC} = 3\text{V}</math>)</b>						
High Level Output Voltage ( $V_{OH}$ )	$I/O$ , $I_{OH} = 20\mu\text{A}$ , DATA = $DV_{CC}$	●	$0.8 \times V_{CC}$			V
Low Level Output Voltage ( $V_{OL}$ )	$I/O$ , $I_{OL} = -1\text{mA}$ , DATA = 0V	●			0.4	V
High Level Output Voltage ( $V_{OH}$ )	RST, CLK, $I_{OH} = 20\mu\text{A}$	●	$0.9 \times V_{CC}$			V
Low Level Output Voltage ( $V_{OL}$ )	RST, CLK, $I_{OL} = -200\mu\text{A}$	●			0.4	V
I/O Pull-Up Resistance	Between I/O and $V_{CC}$		6.5	10	14	$\text{k}\Omega$
<b>SIM Inputs/Outputs (<math>V_{CC} = 1.8\text{V}</math>)</b>						
High Level Output Voltage ( $V_{OH}$ )	$I/O$ , $I_{OH} = 20\mu\text{A}$ , DATA = $DV_{CC}$	●	$0.8 \times V_{CC}$			V
Low Level Output Voltage ( $V_{OL}$ )	$I/O$ , $I_{OL} = -1\text{mA}$ , DATA = 0V	●			0.3	V
High Level Output Voltage ( $V_{OH}$ )	RST, CLK, $I_{OH} = 20\mu\text{A}$	●	$0.9 \times V_{CC}$			V
Low Level Output Voltage ( $V_{OL}$ )	RST, CLK, $I_{OL} = -200\mu\text{A}$	●			$0.2 \times V_{CC}$	V
I/O Pull-Up Resistance	Between I/O and $V_{CC}$		6.5	10	14	$\text{k}\Omega$
<b>SIM Timing Parameters</b>						
CLK Rise/Fall Time	$C_{CLK} = 30\text{pF}$ , $V_{CC} = 1.8\text{V}/3\text{V}$	●			18	ns
RST, I/O Rise/Fall Time	RST, I/O Loaded with 30pF, $V_{CC} = 1.8\text{V}/3\text{V}$	●			1	$\mu\text{s}$
Max CLK Frequency	(Note 3)		5			MHz
$V_{CC}$ Turn-On Time	$\overline{\text{SHDN}} = 1$ , (Note 3)			0.5		ms
$V_{CC}$ Discharge Time to 1V	$\overline{\text{SHDN}} = 0$ , (Note 3)			0.5		ms

**Note 1:** Stresses beyond those listed under Absolute Maximum Ratings may cause permanent damage to the device. Exposure to any Absolute Maximum Rating condition for extended periods may affect device reliability and lifetime.

**Note 2:** The LTC4555E is guaranteed to meet performance specifications from  $0^\circ\text{C}$  to  $85^\circ\text{C}$ . Specifications over the  $-40^\circ\text{C}$  to  $85^\circ\text{C}$  operating temperature range are assured by design, characterization and correlation with statistical process controls.

**Note 3:** Specification is guaranteed by design and not 100% tested in production.

## TYPICAL PERFORMANCE CHARACTERISTICS

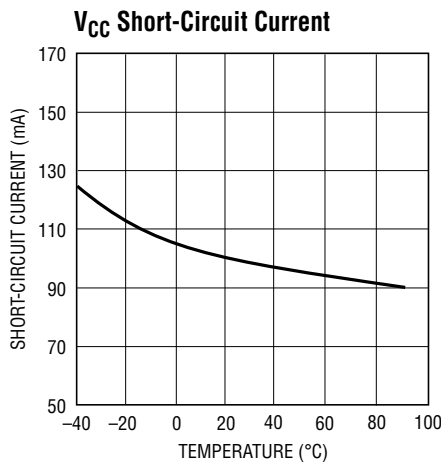

4555 G01

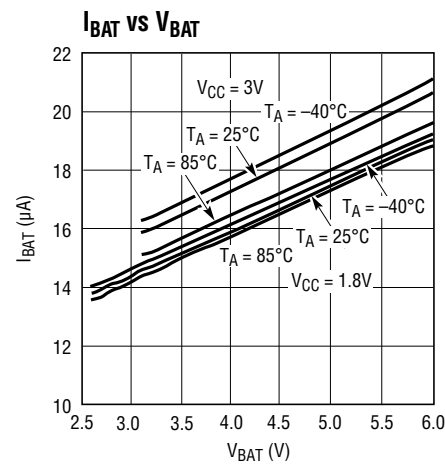

4555 G02

## PIN FUNCTIONS

**SHDN (Pin 1):** Controller Driven Shutdown Pin. This pin should be high (DV<sub>CC</sub>) for normal operation and low to activate a low current shutdown mode.

**V<sub>SEL</sub> (Pin 2):** V<sub>CC</sub> Voltage Select Pin. A low level selects V<sub>CC</sub> = 1.8V while driving this pin to DV<sub>CC</sub> selects V<sub>CC</sub> = 3V.

**DV<sub>CC</sub> (Pin 3):** Supply Voltage for the Controller Side I/O Pins (C<sub>IN</sub>, R<sub>IN</sub>, DATA). When below 1.1V, the V<sub>CC</sub> supply is disabled. This pin should be bypassed with a 0.1µF ceramic capacitor close to the pin.

**NC (Pins 4, 6, 12, 16):** No Connect.

**V<sub>BAT</sub> (Pin 5):** V<sub>CC</sub> Supply Input. This pin can be between 3V and 6V for normal operation. V<sub>BAT</sub> quiescent current reduces to <1µA in shutdown. This pin should be bypassed with a 0.1µF ceramic capacitor close to the pin.

**V<sub>CC</sub> (Pin 7):** SIM Card V<sub>CC</sub> Supply. A 1µF low ESR capacitor needs to be connected close to the V<sub>CC</sub> pin for stable operation. This pin is discharged to GND during shutdown.

**I/O (Pin 8):** SIM-Side Data I/O. The SIM card output must be on an open-drain driver capable of sourcing >1mA.

**RST (Pin 9):** Reset Output Pin for the SIM Card.

**GND (Pin 10):** Ground for the SIM and Controller. Proper grounding and bypassing is required to meet 14kV ESD specifications.

**CLK (Pin 11):** Clock Output Pin for the SIM Card. This pin is pulled to ground during shutdown. Fast rising and falling edges necessitate careful board layout for the CLK node.

**C<sub>IN</sub> (Pin 13):** Clock Input from the Controller.

**R<sub>IN</sub> (Pin 14):** Reset Input from the Controller.

**DATA (Pin 15):** Controller Side Data I/O. This pin is used for bidirectional data transfer. The controller output must be an open-drain configuration. The open-drain output must be capable of sinking greater than 1mA.

**Exposed Pad (Pin 17):** GND. Must be soldered to PCB.

## BLOCK DIAGRAM

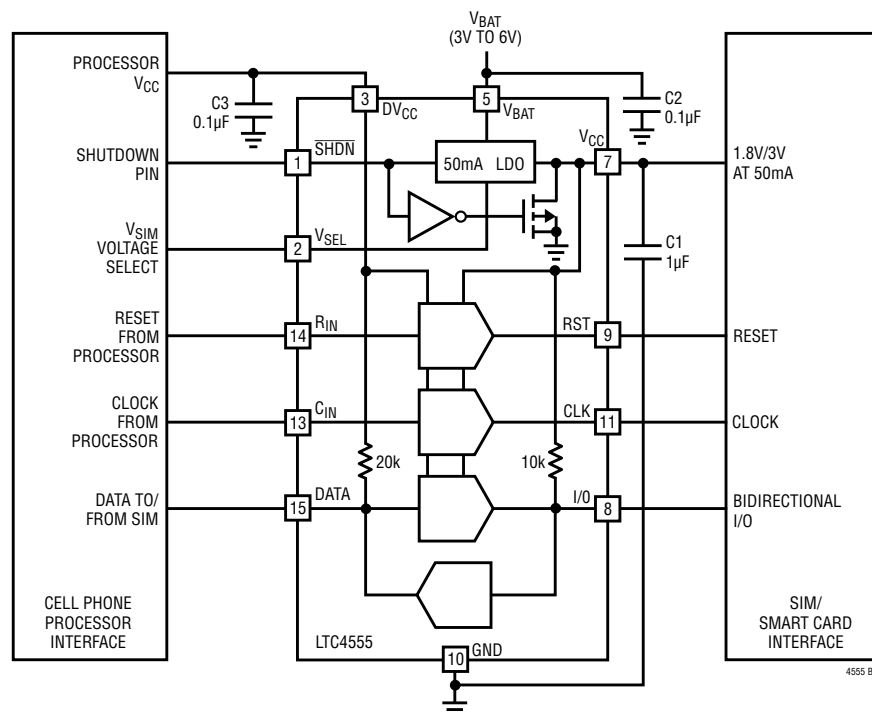

## APPLICATIONS INFORMATION

The LTC4555 provides both regulated power and internal level translators to allow low voltage controllers to interface with 1.8V or 3V SIMs or smart cards. The part meets all ETSI, IMT-2000 and ISO7816 requirements for SIM and smart card interfaces.

### V<sub>CC</sub> Voltage Regulator

The V<sub>CC</sub> voltage regulator is a 50mA low dropout (LDO) regulator with a digitally selected 1.8V or 3V output.

The output voltage is selected via the V<sub>SEL</sub> pin. The output is internally current limited and is capable of surviving an indefinite short to GND.

The V<sub>CC</sub> output should be bypassed with a 1µF capacitor. The LTC4555 can use either a low ESR ceramic capacitor or a tantalum electrolytic capacitor on the V<sub>CC</sub> pin, with no special ESR requirements.

V<sub>BAT</sub> should be bypassed with a 0.1µF ceramic capacitor.

### Level Translators

All SIMs and smart cards contain a clock input, a reset input and a bidirectional data input/output. The LTC4555

provides level translators to allow controllers to communicate with the SIM. The CLK and RST lines to the SIM are level shifted from the controller supply (GND to DV<sub>CC</sub>) to the SIM supply (GND to V<sub>CC</sub>). The data input to the SIM requires an open-drain output on the controller. On-chip pull-up resistors are provided for both the DATA and I/O lines.

### Shutdown Modes

The LTC4555 enters a low current shutdown mode by pulling the SHDN pin low. The SHDN pin is an active low input that the controller can use to directly shut down the part.

### ESD Protection

All pins that connect to the SIM/smart card will withstand 14kV of human body model ESD. In order to ensure proper ESD protection, careful board layout is required. The GND pin should be tied directly to a GND plane. The V<sub>CC</sub> capacitor should be located very close to the V<sub>CC</sub> pin and tied directly to the GND plane.

## PACKAGE DESCRIPTION

Please refer to <http://www.linear.com/product/LTC4555#packaging> for the most recent package drawings.

**UD Package**  
**16-Lead Plastic QFN (3mm × 3mm)**  
 (Reference LTC DWG # 05-08-1691 Rev 0)

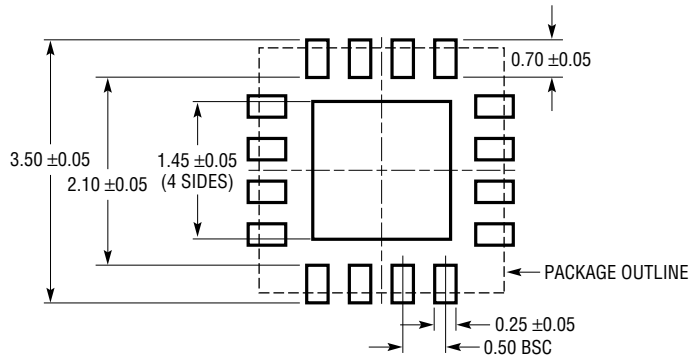

RECOMMENDED SOLDER PAD PITCH AND DIMENSIONS

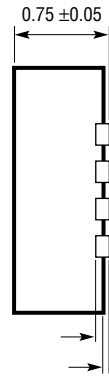
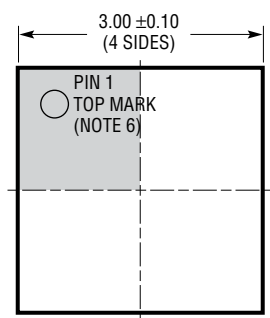

BOTTOM VIEW—EXPOSED PAD

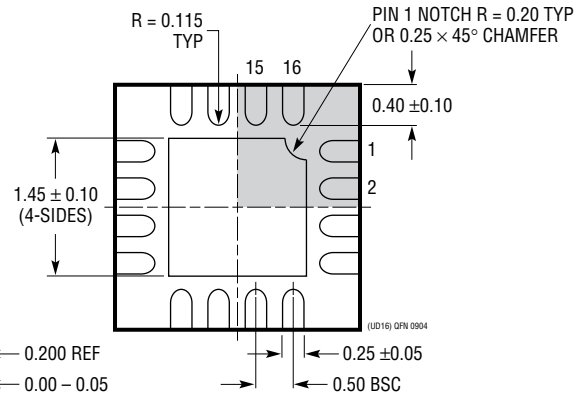

- NOTE:
1. DRAWING CONFORMS TO JEDEC PACKAGE OUTLINE MO-220 VARIATION (WEED-2)
  2. DRAWING NOT TO SCALE
  3. ALL DIMENSIONS ARE IN MILLIMETERS
  4. DIMENSIONS OF EXPOSED PAD ON BOTTOM OF PACKAGE DO NOT INCLUDE MOLD FLASH. MOLD FLASH, IF PRESENT, SHALL NOT EXCEED 0.15mm ON ANY SIDE
  5. EXPOSED PAD SHALL BE SOLDER PLATED
  6. SHADED AREA IS ONLY A REFERENCE FOR PIN 1 LOCATION ON THE TOP AND BOTTOM OF PACKAGE

**REVISION HISTORY** (Revision history begins at Rev C)

REV	DATE	DESCRIPTION	PAGE NUMBER
C	10/16	Added Note 3 to Max CLK Frequency specification	3

## RELATED PARTS

PART NUMBER	DESCRIPTION	COMMENTS
<a href="#">LTC1514</a>	50mA, 650kHz, Step-Up/Down Charge Pump with Low-Battery Comparator	$V_{IN} = 2.7V$ to 10V, $V_{OUT} = 3V/5V$ , $I_Q = 60\mu A$ , $I_{SD} = 10\mu A$ , S8 Package
<a href="#">LTC1515</a>	50mA, 650kHz, Step-Up/Down Charge Pump with Power-On Reset	$V_{IN} = 2.7V$ to 10V, $V_{OUT} = 3.3V$ or 5V, $I_Q = 60\mu A$ , $I_{SD} < 1\mu A$ , S8 Package
<a href="#">LTC1555/LTC1556</a>	650kHz, SIM Power Supply and Level Translator for 3V/5V SIM Cards	$V_{IN} = 2.7V$ to 10V, $V_{OUT} = 3V/5V$ , $I_Q = 60\mu A$ , $I_{SD} < 1\mu A$ , SSOP-16, SSOP-20 Packages
<a href="#">LTC1555L</a>	1MHz, SIM Power Supply and Level Translator for 3V/5V SIM Cards	$V_{IN} = 2.6V$ to 6.6V, $V_{OUT} = 3V/5V$ , $I_Q = 40\mu A$ , $I_{SD} < 1\mu A$ , SSOP-16 Package
<a href="#">LTC1555L-1.8</a>	1MHz, SIM Power Supply and Level Translator for 1.8V/3V/5V SIM Cards	$V_{IN} = 2.6V$ to 6.6V, $V_{OUT} = 1.8V/3V/5V$ , $I_Q = 32\mu A$ , $I_{SD} < 1\mu A$ , SSOP-16
<a href="#">LTC1755/LTC1756</a>	Smart Card Interface with Serial Control for 3V/5V Smart Card Applications	$V_{IN} = 2.7V$ to 7V, $V_{OUT} = 3V/5V$ , $I_Q = 60\mu A$ , $I_{SD} < 1\mu A$ , SSOP-16, SSOP-24
<a href="#">LTC1955</a>	Dual Smart Card Interface with Serial Control for 1.8V/3V/5V Smart Card Applications	$V_{IN} = 3V$ to 6V, $V_{OUT} = 1.8V/3V$ , $I_Q = 200\mu A$ , $I_{SD} < 1\mu A$ , QFN-32 Package
<a href="#">LTC1986</a>	900kHz, SIM Power Supply for 3V/5V SIM Cards	$V_{IN} = 2.6V$ to 4.4V, $V_{OUT} = 3V/5V$ , $I_Q = 14\mu A$ , $I_{SD} < 1\mu A$ , ThinSOT™ Package
<a href="#">LTC3250-1.5</a>	250mA, 1.5MHz, High Efficiency Step-Down Charge Pump	85% Efficiency, $V_{IN} = 3.1V$ to 5.5V, $V_{OUT} = 1.5V$ , $I_Q = 35\mu A$ , $I_{SD} < 1\mu A$ , ThinSOT Package
<a href="#">LTC3251</a>	500mA, 1MHz to 16MHz, Spread Spectrum, Step-Down Charge Pump	85% Efficiency, $V_{IN} = 3.1V$ to 5.5V, $V_{OUT} = 0.9V$ to 1.6V, $I_Q = 9\mu A$ , $I_{SD} < 1\mu A$ , MS Package

## Looking for pricing, stock, or lifecycle information?

Click below to explore more details on WIN SOURCE:

 [View LTC4555EUD#PBF on WIN SOURCE](#)

 [Linear Technology](#) Information

## Optimize Your Supply Chain with WIN SOURCE Solutions

-  Global Sourcing Solution
-  Obsolete Management
-  Cost Control Management
-  Shortage Management
-  Alternative Solution
-  Excess Inventory Management