



**THE DATASHEET OF
LTC2990IMS#PBF**



Quad I²C Voltage, Current and Temperature Monitor

FEATURES

- Measures Voltage, Current and Temperature
- Measures Two Remote Diode Temperatures
- ±0.5°C Accuracy, 0.06°C Resolution (Typ)
- ±1°C Internal Temperature Sensor (Typ)
- 14-Bit ADC Measures Voltage/Current
- 3V to 5.5V Supply Operating Voltage
- Four Selectable Addresses
- Internal 10ppm/°C Voltage Reference
- 10-Lead MSOP Package

APPLICATIONS

- Temperature Measurement
- Supply Voltage Monitoring
- Current Measurement
- Remote Data Acquisition
- Environmental Monitoring

DESCRIPTION

The LTC[®]2990 is used to monitor system temperatures, voltages and currents. Through the I²C serial interface, the device can be configured to measure many combinations of internal temperature, remote temperature, remote voltage, remote current and internal V_{CC}. The internal 10ppm/°C reference minimizes the number of supporting components and area required. Selectable address and configurable functionality give the LTC2990 flexibility to be incorporated in various systems needing temperature, voltage or current data. The LTC2990 fits well in systems needing sub-millivolt voltage resolution, 1% current measurement and 1°C temperature accuracy or any combination of the three.

All registered trademarks and trademarks are the property of their respective owners.

TYPICAL APPLICATION

Voltage, Current, Temperature Monitor

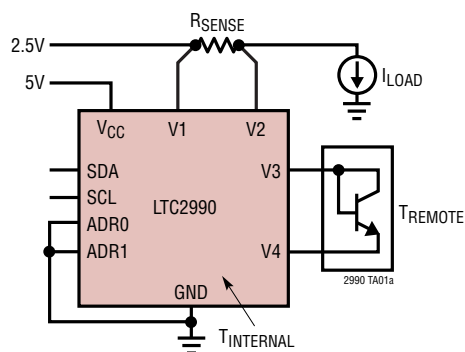

MEASURES: TWO SUPPLY VOLTAGES,
SUPPLY CURRENT, INTERNAL AND
REMOTE TEMPERATURES

Temperature Total Unadjusted Error

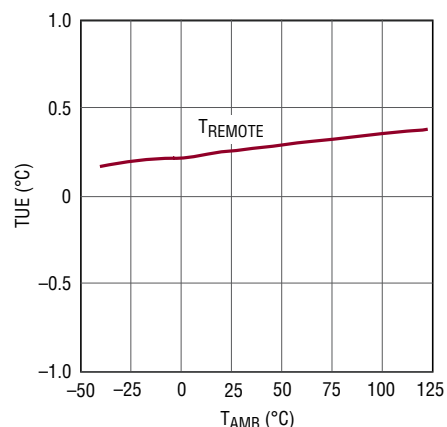

2990 TA01b

LTC2990

ABSOLUTE MAXIMUM RATINGS

(Note 1)

Supply Voltage V_{CC}	-0.3V to 6.0V
Input Voltages V1, V2, V3, V4, SDA, SCL, ADR1, ADR2.....	-0.3V to ($V_{CC} + 0.3V$)
Operating Temperature Range	
LTC2990C.....	0°C to 70°C
LTC2990I.....	-40°C to 85°C
Storage Temperature Range.....	-65°C to 150°C
Lead Temperature (Soldering, 10 sec).....	300°C

PIN CONFIGURATION

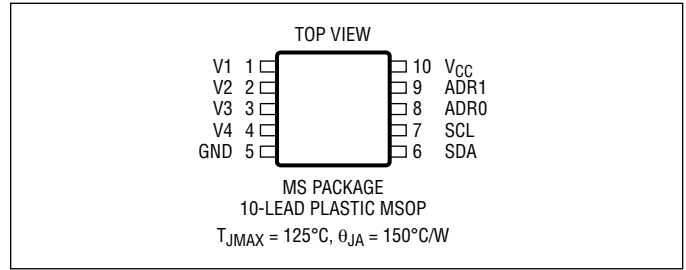

ORDER INFORMATION

LEAD FREE FINISH	TAPE AND REEL	PART MARKING*	PACKAGE DESCRIPTION	TEMPERATURE RANGE
LTC2990CMS#PBF	LTC2990CMS#TRPBF	LTDSQ	10-Lead Plastic MSOP	0°C to 70°C
LTC2990IMS#PBF	LTC2990IMS#TRPBF	LTDSQ	10-Lead Plastic MSOP	-40°C to 85°C
LEAD BASED FINISH	TAPE AND REEL	PART MARKING*	PACKAGE DESCRIPTION	TEMPERATURE RANGE
LTC2990CMS	LTC2990CMS#TR	LTDSQ	10-Lead Plastic MSOP	0°C to 70°C
LTC2990IMS	LTC2990IMS#TR	LTDSQ	10-Lead Plastic MSOP	-40°C to 85°C

Consult the factory for parts specified with wider operating temperature ranges. *The temperature grade is identified by a label on the shipping container. Contact the factory for parts trimmed to ideality factors other than 1.004.

[Tape and reel specifications](#). Some packages are available in 500 unit reels through designated sales channels with #TRMPBF suffix.

ELECTRICAL CHARACTERISTICS

The ● denotes the specifications which apply over the full operating temperature range, otherwise specifications are at $T_A = 25^\circ\text{C}$. $V_{CC} = 3.3V$, unless otherwise noted.

SYMBOL	PARAMETER	CONDITIONS	MIN	TYP	MAX	UNITS	
General							
V_{CC}	Input Supply Range		●	2.9	5.5	V	
I_{CC}	Input Supply Current	During Conversion, I^2C Inactive	●	1.1	1.8	mA	
I_{SD}	Input Supply Current	Shutdown Mode, I^2C Inactive	●	1	5	μA	
$V_{CC(UVL)}$	Input Supply Undervoltage Lockout		●	1.3	2.1	2.7	V
Measurement Accuracy							
$T_{INT(TUE)}$	Internal Temperature Total Unadjusted Error	$T_{AMB} = 0^\circ\text{C to } 85^\circ\text{C}$ $T_{AMB} = -40^\circ\text{C to } 0^\circ\text{C}$		±0.5 ±1 ±3	±3.5	°C °C °C	
$T_{RMT(TUE)}$	Remote Diode Temperature Total Unadjusted Error	$\eta = 1.004$ (Note 4)	●	±0.5	±1.5	°C	
$V_{CC(TUE)}$	V_{CC} Voltage Total Unadjusted Error		●	±0.1	±0.25	%	
$V_{N(TUE)}$	V1 Through V4 Total Unadjusted Error		●	±0.1	±0.25	%	
$V_{DIFF(TUE)}$	Differential Voltage Total Unadjusted Error V1 – V2 or V3 – V4	$-300\text{mV} \leq V_D \leq 300\text{mV}$	●	±0.2	±0.75	%	
$V_{DIFF(MAX)}$	Maximum Differential Voltage		●	-300	300	mV	

Rev. F

ELECTRICAL CHARACTERISTICS

The ● denotes the specifications which apply over the full operating temperature range, otherwise specifications are at $T_A = 25^\circ\text{C}$. $V_{CC} = 3.3\text{V}$, unless otherwise noted.

SYMBOL	PARAMETER	CONDITIONS	MIN	TYP	MAX	UNITS
$V_{\text{OFFSET_DIFF}}$	Differential Offset	$V_1 = V_2 = V_{CC}$, $V_3 = V_4 = 0\text{V}$	-12.5	0	12.5	LSB
$V_{\text{OFFSET_SE}}$	Single-Ended Offset	$V_1, V_2, V_3, V_4 = 0\text{V}$	-6	0	6	LSB
$V_{\text{DIFF(CMR)}}$	Differential Voltage Common Mode Range	●	0		V_{CC}	V
$V_{\text{LSB(DIFF)}}$	Differential Voltage LSB Weight			19.42		μV
$V_{\text{LSB(SINGLE-ENDED)}}$	Single-Ended Voltage LSB Weight			305.18		μV
$V_{\text{LSB(TEMP)}}$	Temperature LSB Weight	Celsius or Kelvin		0.0625		Deg
T_{NOISE}	Temperature Noise	Celsius or Kelvin $T_{\text{MEAS}} = 46\text{ms}$ (Note 2)		0.2 0.05		$^\circ\text{RMS}$ $\%/\sqrt{\text{Hz}}$
Res	Resolution (No Missing Codes)	(Note 2)	●	14		Bits
INL	Integral Nonlinearity	$2.9\text{V} \leq V_{CC} \leq 5.5\text{V}$, $V_{\text{IN(CM)}} = 1.5\text{V}$ (Note 2) Single-Ended Differential	●	-2 -2	2 2	LSB LSB
C_{IN}	V_1 Through V_4 Input Sampling Capacitance	(Note 2)		0.35		pF
$I_{\text{IN(AVG)}}$	V_1 Through V_4 Input Average Sampling Current	$0\text{V} \leq V_N \leq 3\text{V}$ (Note 2)		0.6		μA
$I_{\text{DC_LEAK(VIN)}}$	V_1 Through V_4 Input Leakage Current	$0\text{V} \leq V_N \leq V_{CC}$	●	-10	10	nA

Measurement Delay

$T_{\text{INT}}, T_{\text{R1}}, T_{\text{R2}}$	Per Configured Temperature Measurement	(Note 2)	●	37	46	55	ms
V_1, V_2, V_3, V_4	Single-Ended Voltage Measurement	(Note 2) Per Voltage, Two Minimum	●	1.2	1.5	1.8	ms
$V_1 - V_2, V_3 - V_4$	Differential Voltage Measurement	(Note 2)	●	1.2	1.5	1.8	ms
V_{CC}	V_{CC} Measurement	(Note 2)	●	1.2	1.5	1.8	ms
Max Delay	Mode[4:0] = 11101, $T_{\text{INT}}, T_{\text{R1}}, T_{\text{R2}}, V_{CC}$	(Note 2)	●			167	ms

V_1, V_3 Output (Remote Diode Mode Only)

I_{OUT}	Output Current	Remote Diode Mode	●	260	350	μA
V_{OUT}	Output Voltage		●	0	V_{CC}	V

I²C Interface

$V_{\text{ADR(L)}}$	ADRO, ADR1 Input Low Threshold Voltage	Falling	●		$0.3 \cdot V_{CC}$	V
$V_{\text{ADR(H)}}$	ADRO, ADR1 Input High Threshold Voltage	Rising	●	$0.7 \cdot V_{CC}$		V
V_{OL1}	SDA Low Level Maximum Voltage	$I_0 = -3\text{mA}$, $V_{CC} = 2.9\text{V}$ to 5.5V	●		0.4	V
V_{IL}	Maximum Low Level Input Voltage	SDA and SCL Pins	●		$0.3 \cdot V_{CC}$	V
V_{IH}	Minimum High Level Input Voltage	SDA and SCL Pins	●	$0.7 \cdot V_{CC}$		V
$I_{\text{SDA,SCL}}$	SDA, SCL Input Current	$0 < V_{\text{SDA,SCL}} < V_{CC}$	●		± 1	μA
$I_{\text{ADR(MAX)}}$	Maximum ADRO, ADR1 Input Current	ADRO or ADR1 Tied to V_{CC} or GND	●		± 1	μA

I²C Timing (Note 2)

$f_{\text{SCL(MAX)}}$	Maximum SCL Clock Frequency			400		kHz
t_{LOW}	Minimum SCL Low Period				1.3	μs
t_{HIGH}	Minimum SCL High Period				600	ns
$t_{\text{BUF(MIN)}}$	Minimum Bus Free Time Between Stop/Start Condition				1.3	μs
$t_{\text{HD,STA(MIN)}}$	Minimum Hold Time After (Repeated) Start Condition				600	ns

ELECTRICAL CHARACTERISTICS

The ● denotes the specifications which apply over the full operating temperature range, otherwise specifications are at $T_A = 25^\circ\text{C}$. $V_{CC} = 3.3\text{V}$, unless otherwise noted.

SYMBOL	PARAMETER	CONDITIONS	MIN	TYP	MAX	UNITS
$t_{\text{SU,STA(MIN)}}$	Minimum Repeated Start Condition Set-Up Time				600	ns
$t_{\text{SU,STO(MIN)}}$	Minimum Stop Condition Set-Up Time				600	ns
$t_{\text{HD,DAT(MIN)}}$	Minimum Data Hold Time Input				0	ns
$t_{\text{HD,DATO(MIN)}}$	Minimum Data Hold Time Output		300		900	ns
$t_{\text{SU,DAT(MIN)}}$	Minimum Data Set-Up Time Input				100	ns
$t_{\text{SP(MAX)}}$	Maximum Suppressed Spike Pulse Width		50		250	ns
C_X	SCL, SDA Input Capacitance				10	pF

Note 1: Stresses beyond those listed under Absolute Maximum Ratings may cause permanent damage to the device. Exposure to any Absolute Maximum Rating condition for extended periods may affect device reliability and lifetime.

Note 2: Guaranteed by design and not subject to test.

Note 3: Integral nonlinearity is defined as the deviation of a code from a straight line passing through the actual endpoints of the transfer curve. The deviation is measured from the center of the quantization band.

Note 4: Trimmed to an ideality factor of 1.004 at 25°C . Remote diode temperature drift (TUE) verified at diode voltages corresponding to the temperature extremes with the LTC2990 at 25°C . Remote diode temperature drift (TUE) guaranteed by characterization over the LTC2990 operating temperature range.

TYPICAL PERFORMANCE CHARACTERISTICS $T_A = 25^\circ\text{C}$, $V_{CC} = 3.3\text{V}$ unless otherwise noted

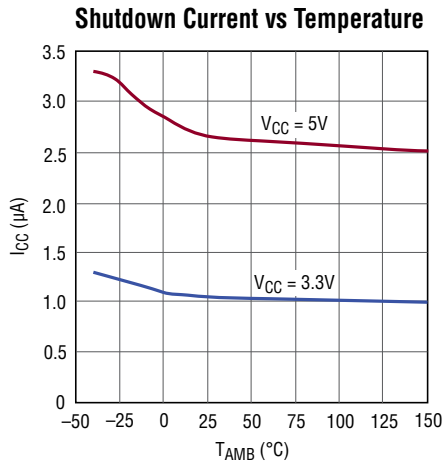

2990 G01

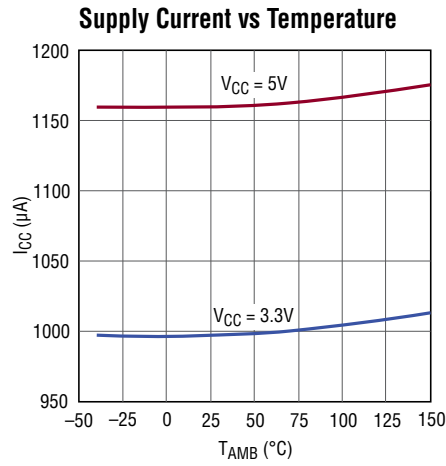

2990 G02

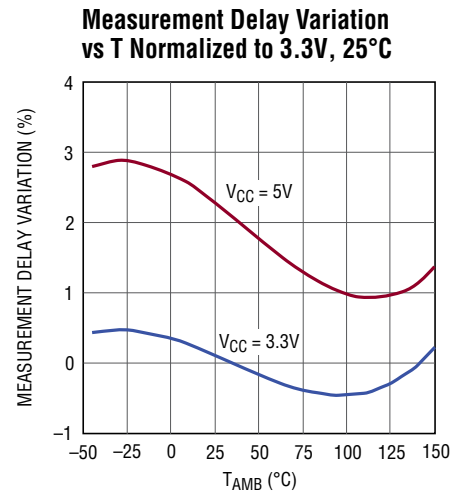

2990 G03

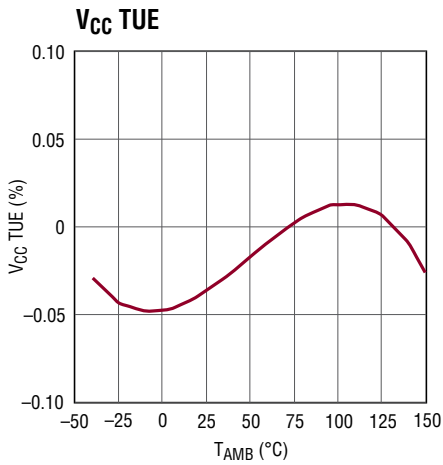

2990 G04

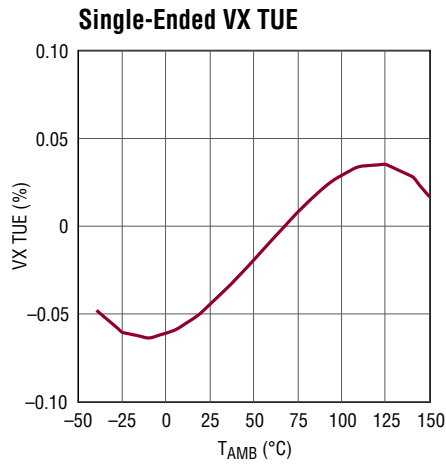

2990 G05

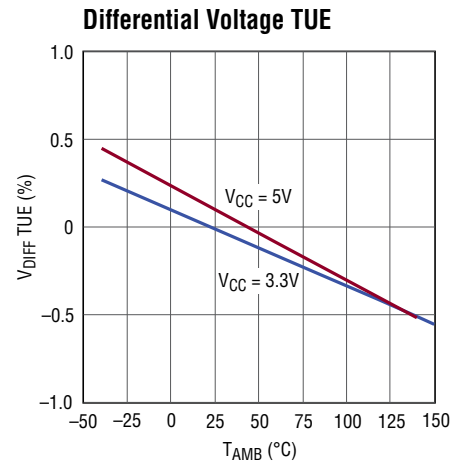

2990 G06

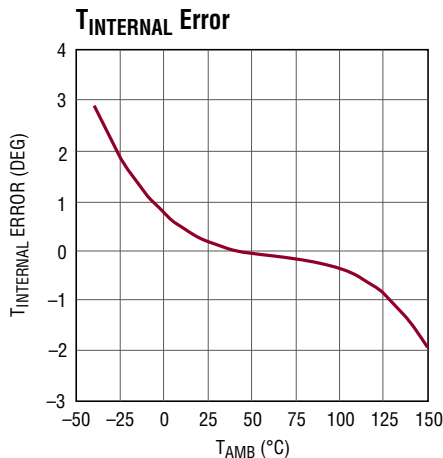

2990 G07

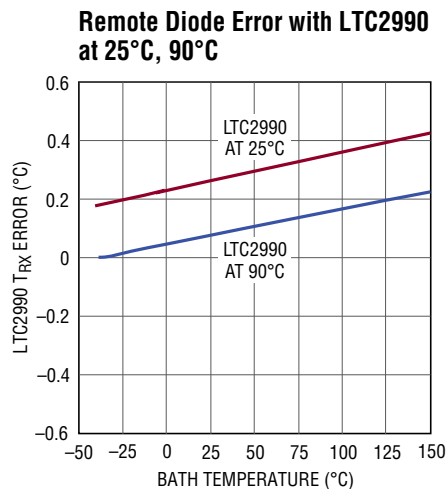

2990 G08

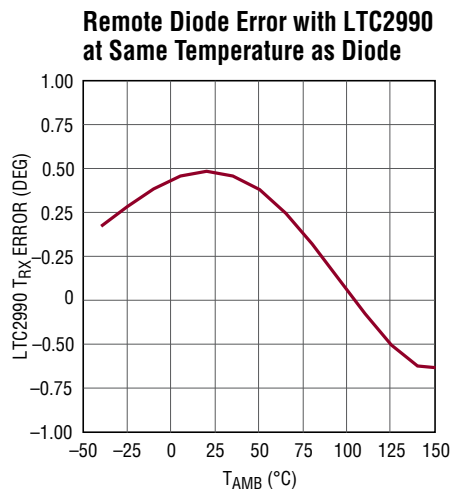

2990 G09

TYPICAL PERFORMANCE CHARACTERISTICS $T_A = 25^\circ\text{C}$, $V_{CC} = 3.3\text{V}$ unless otherwise noted

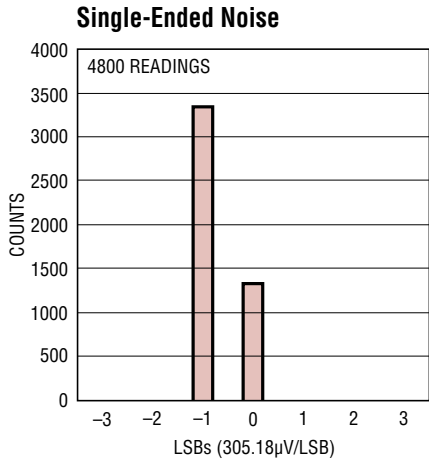

2990 G10

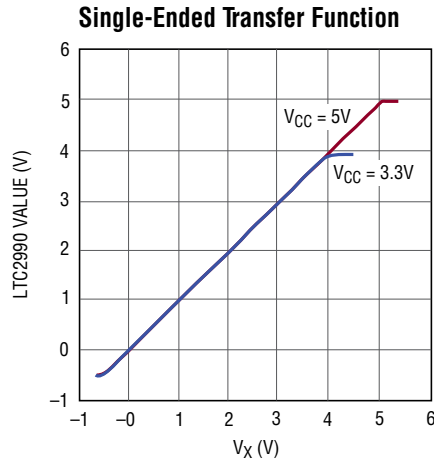

2990 G11

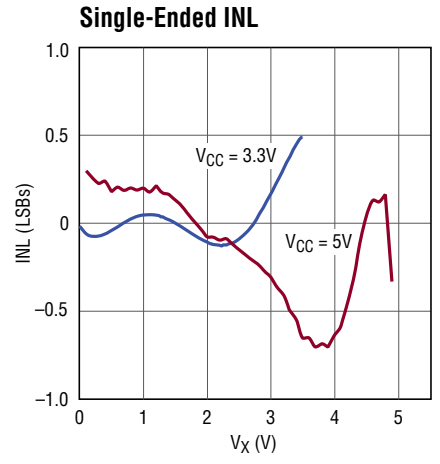

2990 G12

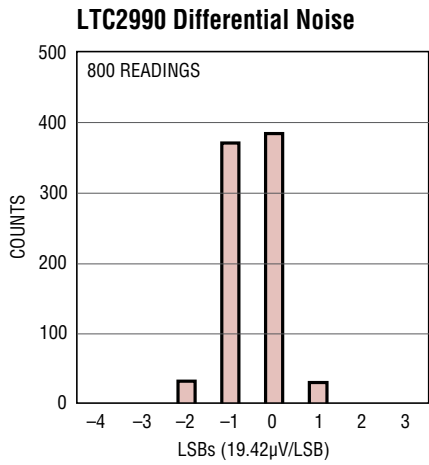

2990 G13

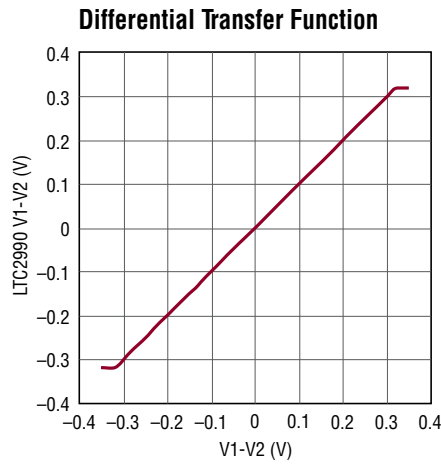

2990 G14

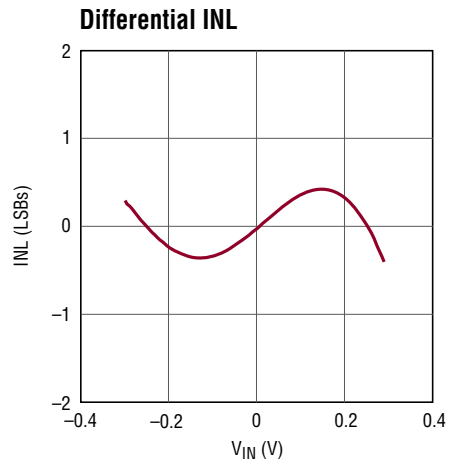

2990 G15

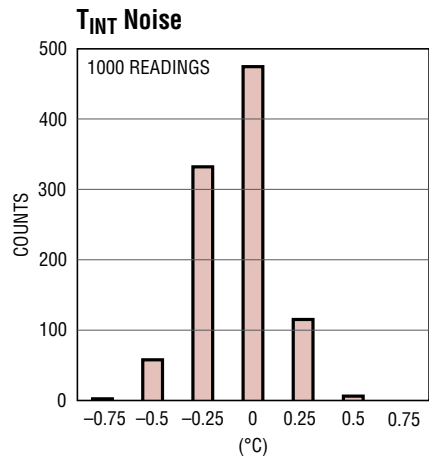

2990 G16

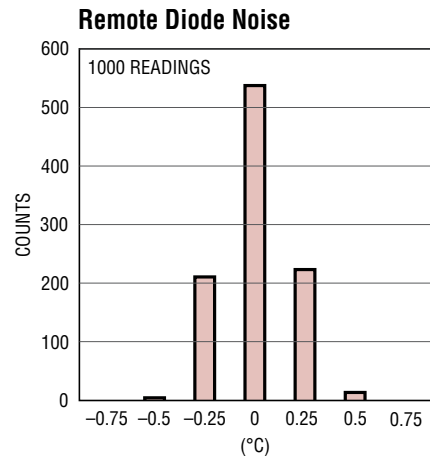

2990 G17

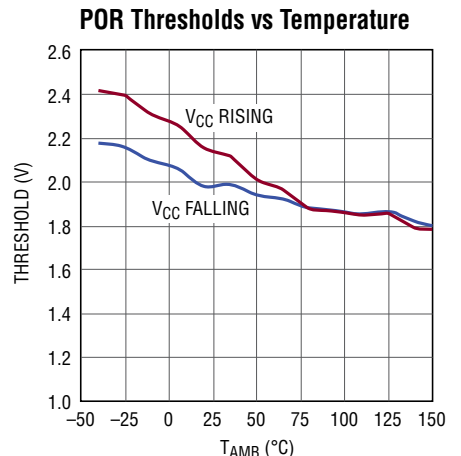

2990 G18

PIN FUNCTIONS

V1 (Pin 1): First Monitor Input. This pin can be configured as a single-ended input or the positive input for a differential or remote diode temperature measurement (in combination with V2). When configured for remote diode temperature, this pin will source a current.

V2 (Pin 2): Second Monitor Input. This pin can be configured as a single-ended input or the negative input for a differential or remote diode temperature measurement (in combination with V1). When configured for remote diode temperature, this pin will have an internal termination, while the measurement is active.

V3 (Pin 3): Third Monitor Input. This pin can be configured as a single-ended input or the positive input for a differential or remote diode temperature measurement (in combination with V4). When configured for remote diode temperature, this pin will source a current.

V4 (Pin 4): Fourth Monitor Input. This pin can be configured as a single-ended input or the negative input for a differential or remote diode temperature measurement (in combination with V3). When configured for remote diode temperature, this pin will have an internal termination, while the measurement is active.

GND (Pin 5): Device Circuit Ground. Connect this pin to a ground plane through a low impedance connection.

SDA (Pin 6): Serial Bus Data Input and Output. In the transmitter mode (Read), the conversion result is output through the SDA pin, while in the receiver mode (Write), the device configuration bits are input through the SDA pin. At data input mode, the pin is high impedance; while at data output mode, it is an open-drain N-channel driver and therefore an external pull-up resistor or current source to V_{CC} is needed.

SCL (Pin 7): Serial Bus Clock Input. The LTC2990 can only act as a slave and the SCL pin only accepts external serial clock. The LTC2990 does not implement clock stretching.

ADRO (Pin 8): Serial Bus Address Control Input. The ADRO pin is an address control bit for the device I²C address. See Table 2.

ADR1 (Pin 9): Serial Bus Address Control Input. The ADR1 pin is an address control bit for the device I²C address. See Table 2.

V_{CC} (Pin 10): Supply Voltage Input.

FUNCTIONAL DIAGRAM

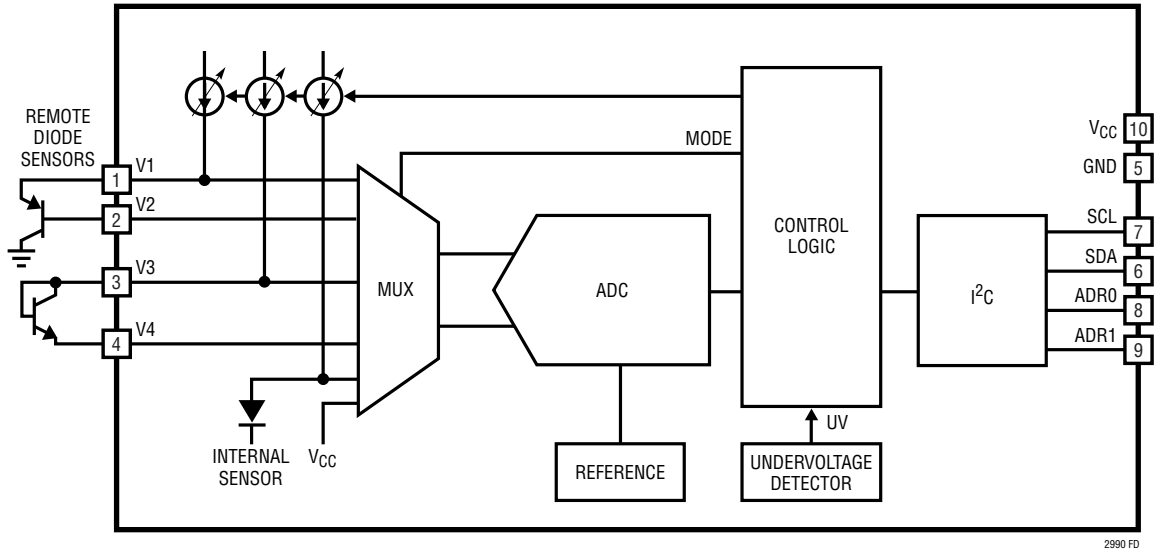

TIMING DIAGRAM

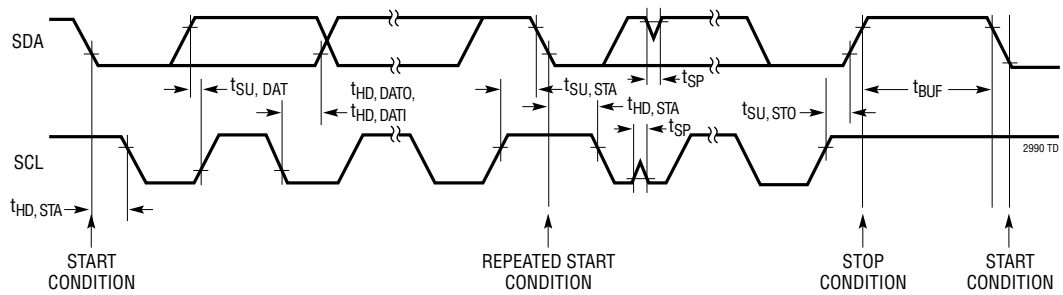

OPERATION

The LTC2990 monitors voltage, current, internal and remote temperatures. It can be configured through an I²C interface to measure many combinations of these parameters. Single or repeated measurements are possible. Remote temperature measurements use a transistor as a temperature sensor, allowing the remote sensor to be a discrete NPN (ex. MMBT3904) or an embedded PNP device in a microprocessor or FPGA. The internal ADC reference minimizes the number of support components required.

The Functional Diagram displays the main components of the device. The input signals are selected with an input MUX, controlled by the control logic block. The control logic uses the mode bits in the control register to manage the sequence and types of data acquisition. The control logic also controls the variable current sources during remote temperature acquisition. The order of acquisitions is fixed: T_{INTERNAL}, V1, V2, V3, V4 then V_{CC}. The ADC performs the necessary conversion(s) and supplies the data to the control logic for further processing in the case of temperature measurements, or routing to the appropriate data register for voltage and current measurements. Current and temperature measurements, V1 – V2 or V3 – V4, are sampled differentially by the internal ADC. The I²C interface supplies access to control, status and data registers. The ADR1 and ADR0 pins select one of four possible I²C addresses (see Table 2). The undervoltage

detector inhibits I²C communication below the specified threshold. During an undervoltage condition, the part is in a reset state, and the data and control registers are placed in the default state of 00h.

Remote diode measurements are conducted using multiple ADC conversions and source currents to compensate for sensor series resistance. During temperature measurements, the V2 or V4 terminal of the LTC2990 is terminated with a diode. The LTC2990 is calibrated to yield the correct temperature for a remote diode with an ideality factor of 1.004. See the applications section for compensation of sensor ideality factors other than the factory calibrated value of 1.004.

The LTC2990 communicates through an I²C serial interface. The serial interface provides access to control, status and data registers. I²C defines a 2-wire open-drain interface supporting multiple slave devices and masters on a single bus. The LTC2990 supports 100kbits/s in the standard mode and up to 400kbit/s in fast mode. The four physical addresses supported are listed in Table 2. The I²C interface is used to trigger single conversions, or start repeated conversions by writing to a dedicated trigger register. The data registers contain a destructive-read status bit (data valid), which is used in repeated mode to determine if the register's contents have been previously read. This bit is set when the register is updated with new data, and cleared when read.

APPLICATIONS INFORMATION

Figure 1 is the basic LTC2990 application circuit.

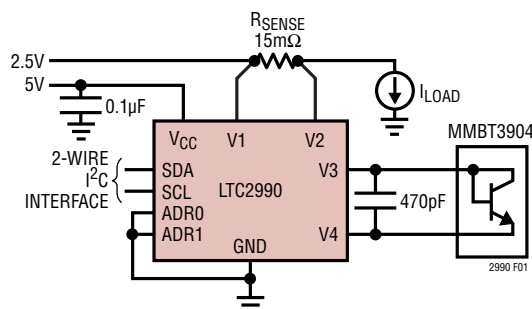

Figure 1.

Power Up

The V_{CC} pin must exceed the undervoltage (UV) threshold of 2.5V to keep the LTC2990 out of power-on reset. Power-on reset will clear all of the data registers and the control register.

Temperature Measurements

The LTC2990 can measure internal temperature and up to two external diode or transistor sensors. During temperature conversion, current is sourced through either the V1 or the V3 pin to forward bias the sensing diode. The

APPLICATIONS INFORMATION

change in sensor voltage per degree temperature change is $275\mu\text{V}/^\circ\text{C}$, so environmental noise must be kept to a minimum. Recommended shielding and PCB trace considerations are illustrated in Figure 2.

The diode equation:

$$V_{BE} = \eta \cdot \frac{k \cdot T}{q} \cdot \ln\left(\frac{I_C}{I_S}\right) \quad (1)$$

can be solved for T, where T is Kelvin degrees, I_S is a process dependent factor on the order of $1\text{E}-13$, η is the diode ideality factor, k is Boltzmann's constant and q is the electron charge.

$$T = \frac{V_{BE} \cdot q}{\eta \cdot k \cdot \ln\left(\frac{I_C}{I_S}\right)} \quad (2)$$

The LTC2990 makes differential measurements of diode voltage to calculate temperature. Proprietary techniques allow for cancellation of error due to series resistance.

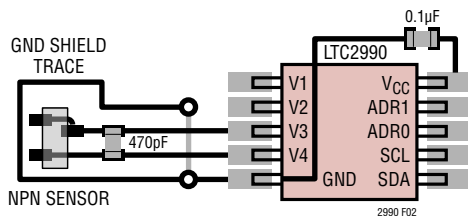

Figure 2. Recommended PCB Layout

Ideality Factor Scaling

The LTC2990 is factory calibrated for an ideality factor of 1.004, which is typical of the popular MMBT3904 NPN transistor. The semiconductor purity and wafer-level processing limits device-to-device variation, making these devices interchangeable (typically $<0.5^\circ\text{C}$) for no additional cost. Several manufacturers supply suitable transistors, some recommended sources are listed in Table 1. Discrete 2-terminal diodes are not recommended as temperature sensors. While an ideality factor value of 1.004 is typical of target sensors, small deviations can yield significant temperature errors. Contact LTC Marketing for parts trimmed to ideality factors other than 1.004. The

Table 1. Recommended Transistors to Be Used as Temperature Sensors

MANUFACTURER	PART NUMBER	PACKAGE
Fairchild Semiconductor	MMBT3904	SOT-23
	FMMT3904	SOT-23
Central Semiconductor	CMPT3904	SOT-23
	CET3904E	SOT-883L
Diodes, Inc.	MMBT3904	SOT-23
On Semiconductor	MMBT3904LT1	SOT-23
NXP	MMBT3904	SOT-23
Infineon	MMBT3904	SOT-23
Rohm	UMT3904	SC-70

ideality factor of the diode sensor can be considered a temperature scaling factor. The temperature error for a 1% accurate ideality factor error is 1% of the Kelvin temperature. Thus, at 25°C , or 298K, a +1% accurate ideality factor error yields a +2.98 degree error. At 85°C or 358K, a +1% error yields a 3.6 degree error. It is possible to scale the measured Kelvin or Celsius temperature measured using the LTC2990 with a sensor ideality factor other than 1.004, to the correct value. The scaling Equations (3) and (4) are simple, and can be implemented with sufficient precision using 16-bit fixed-point math in a microprocessor or microcontroller.

Factory Ideality Calibration Value:

$$\eta_{\text{CAL}} = 1.004$$

Actual Sensor Ideality Value:

$$\eta_{\text{ACT}}$$

Compensated Kelvin Temperature:

$$T_{K_COMP} = \frac{\eta_{\text{CAL}}}{\eta_{\text{ACT}}} \cdot T_{K_MEAS} \quad (3)$$

Compensated Celsius Temperature

$$T_{C_COMP} = \left[\frac{\eta_{\text{CAL}}}{\eta_{\text{ACT}}} \cdot (T_{C_MEAS} + 273) \right] - 273 \quad (4)$$

A 16-bit unsigned number is capable of representing the ratio $\eta_{\text{CAL}}/\eta_{\text{ACT}}$ in a range of 0.00003 to 1.99997, by multiplying the fractional ratio by 2^{15} . The range of scaling encompasses every conceivable target sensor value. The ideality factor scaling granularity yields a worst-case

APPLICATIONS INFORMATION

temperature error of 0.01° at 125°C. Multiplying this 16-bit unsigned number and the measured Kelvin (unsigned) temperature represented as a 16-bit number, yields a 32-bit unsigned result. To scale this number back to a 13-bit temperature (9-bit integer part, and a 4-bit fractional part), divide the number by 2^{15} per Equation (5). Similarly, Celsius coded temperature values can be scaled using 16-bit fixed-point arithmetic, using Equation (6). In both cases, the scaled result will have a 9-bit integer (d[12:4]) and the 4LSBs (d[3:0]) representing the 4-bit fractional part. To convert the corrected result to decimal, divide the final result by 2^4 or 16, as you would the register contents. If ideality factor scaling is implemented in the target application, it is beneficial to configure the LTC2990 for Kelvin coded results to limit the number of math operations required in the target processor.

$$T_{K_COMP} = \frac{(\text{Unsigned}) \left(\frac{\eta_{CAL}}{\eta_{ACT}} 2^{15} \right) T_{K_MEAS}}{2^{15}} \quad (5)$$

$$T_{C_COMP} = \frac{(\text{Unsigned}) \left(\frac{\eta_{CAL}}{\eta_{ACT}} 2^{15} \right) (T_{C_MEAS} + 273.15 \cdot 2^4)}{2^{15}} - 273.15 \cdot 2^4 \quad (6)$$

Sampling Currents

Single-ended voltage measurements are directly sampled by the internal ADC. The average ADC input current is a function of the input applied voltage as follows:

$$I_{IN(AVG)} = (V_{IN} - 1.49V) \cdot 0.17[\mu A/V]$$

Inputs with source resistance less than 200Ω will yield full-scale gain errors due to source impedance of <1/2LSB for 14-bit conversions. The nominal conversion time is 1.5ms for single-ended conversions.

Current Measurements

The LTC2990 has the ability to perform 14-bit current measurements with the addition of a current sense resistor (see Figure 3).

In order to achieve accurate current sensing a few details must be considered. Differential voltage or current measurements are directly sampled by the internal ADC.

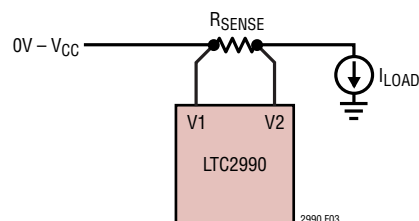

Figure 3. Simplified Current Sense Schematic

The average ADC input current for each leg of the differential input signal during a conversion is $(V_{IN} - 1.49V) \cdot 0.34[\mu A/V]$. The maximum source impedance to yield 14-bit results with, 1/2LSB full-scale error is $\sim 50\Omega$. In order to achieve high accuracy 4-point, or Kelvin connected measurements of the sense resistor differential voltage are necessary.

In the case of current measurements, the external sense resistor is typically small, and determined by the full-scale input voltage of the LTC2990. The full-scale differential voltage is 0.300V. The external sense resistance is then a function of the maximum measurable current, or $R_{EXT_MAX} = 0.300V/I_{MAX}$. For example, if you wanted to measure a current range of $\pm 5A$, the external shunt resistance would equal $0.300V/5A = 60m\Omega$.

There exists a way to improve the sense resistor's precision using the LTC2990. The LTC2990 measures both differential voltage and remote temperature. It is therefore, possible to compensate for the absolute resistance tolerance of the sense resistor and the temperature coefficient of the sense resistor in software. The resistance would be measured by running a calibrated test current through the discrete resistor. The LTC2990 would measure both the differential voltage across this resistor and the resistor temperature. From this measurement, R_0 and T_0 in the equation below would be known. Using the two equations, the host microprocessor could compensate for both the absolute tolerance and the TCR.

$$R_T = R_0 \cdot [1 + \alpha(T - T_0)]$$

where:

$$\alpha = +3930 \text{ ppm}/^\circ\text{C for copper trace}$$

$$\alpha = \pm 2 \text{ to } \sim 200 \text{ ppm}/^\circ\text{C for discrete R} \quad (7)$$

$$I = (V1 - V2)/R_T \quad (8)$$

APPLICATIONS INFORMATION

Device Configuration

The LTC2990 is configured by writing the control register through the serial interface. Refer to Table 5 for control register bit definition. The device is capable of many application configurations including voltage, temperature and current measurements. It is possible to configure the device for single or repeated acquisitions. The device can make single measurements, or in continuous mode, repeated acquisitions. When the device is configured for multiple measurements, the order of the measurements is fixed. For repeated acquisitions, only an initial trigger is required after which data registers are continuously refreshed with new data. As each new data result is ready, the MSB of the corresponding data register is set, and the corresponding status register bit is set. These bits are cleared when the corresponding data register is addressed. The configuration register value at power-up causes the part to measure only the internal temperature sensor when triggered. The four input pins V1 through V4 will be in a high impedance state, until configured otherwise, and a measurement is triggered. The data registers are double-buffered in order to ensure upper and lower data bytes do not become out of sync. Read operations must be terminated in order to avoid an indefinitely paused wait state. Reading the STATUS register does not interrupt measurement data updates. In a polling system, it is recommended that the STATUS register be tested for new data, this prevents unnecessary delays updating the measurement registers.

Data Format

The data registers are broken into 8-bit upper and lower bytes. Voltage and current conversions are 14-bits. The upper bits in the MSB registers provide status on the resulting conversions. These status bits are different for temperature and voltage conversions:

Temperature: Temperature conversions are reported as Celsius or Kelvin results described in Table 8 and Table 9, each with 0.0625 degree-weighted LSBs. The format is controlled by the control register, Bit 7. All temperature formats, T_{INT} , T_{R1} and T_{R2} are controlled by this bit. The Temperature MSB result register most significant bit (Bit 7) is the DATA_VALID bit, which indicates whether the current register contents have been accessed since the result was written to the register. This bit will be set

when new data is written to the register, and cleared when accessed. Bit 6 of the register is a sensor-shorted alarm. This bit of the corresponding register will be high if the remote sensor diode differential voltage is below 0.14V. The LTC2990 internal bias circuitry maintains this voltage above this level during normal operating conditions. Bit 5 of the register is a sensor open alarm. This bit of the corresponding register will be high if the remote sensor diode differential voltage is above 1.0V_{DC}. The LTC2990 internal bias circuitry maintains this voltage below this level during normal operating conditions. The two sensor alarms are only valid after a completed conversion indicated by the data_valid bit being high. Bit 4 through Bit 0 of the MSB register are the conversion result bits D[12:8], in two's complement format. Note in Kelvin results, the result will always be positive. The LSB register contains temperature result bits D[7:0]. To convert the register contents to temperature, use the following equation:

$$T = D[12:0]/16.$$

See Table 10 for conversion value examples.

Voltage/Current: Voltage results are reported in two respective registers, an MSB and LSB register. The Voltage MSB result register most significant bit (Bit 7) is the data_valid bit, which indicates whether the current register contents have been accessed since the result was written to the register. This bit will be set when the register contents are new, and cleared when accessed. Bit 6 of the MSB register is the sign bit, Bits 5 through 0 represent bits D[13:8] of the two's complement conversion result. The LSB register holds conversion bits D[7:0]. The LSB value is different for single-ended voltage measurements V1 through V4, and differential (current measurements) V1 – V2 and V3 – V4. Single-ended voltages are limited to positive values in the range 0V to 3.5V. Differential voltages can have input values in the range of –0.300V to 0.300V.

Use the following equations to convert the register values (see Table 10 for examples):

$$\begin{aligned} V_{\text{SINGLE-ENDED}} &= D[14:0] \cdot 305.18\mu\text{V}, \text{ if Sign} = 0 \\ V_{\text{SINGLE-ENDED}} &= (\overline{D[14:0]} + 1) \cdot -305.18\mu\text{V}, \text{ if Sign} = 1 \\ V_{\text{DIFFERENTIAL}} &= D[14:0] \cdot 19.42\mu\text{V}, \text{ if Sign} = 0 \\ V_{\text{DIFFERENTIAL}} &= (\overline{D[14:0]} + 1) \cdot -19.42\mu\text{V}, \text{ if Sign} = 1 \end{aligned}$$

APPLICATIONS INFORMATION

$$\begin{aligned} \text{Current} &= D[14:0] \cdot 19.42\mu\text{V}/R_{\text{SENSE}}, \text{ if Sign} = 0 \\ \text{Current} &= (\overline{D[14:0]} + 1) \cdot -19.42\mu\text{V}/R_{\text{SENSE}}, \text{ if Sign} = 1 \end{aligned}$$

where R_{SENSE} is the current sensing resistor, typically $<1\Omega$.

V_{CC}: The LTC2990 measures V_{CC} . To convert the contents of the V_{CC} register to voltage, use the following equation:

$$V_{\text{CC}} = 2.5 + D[13:0] \cdot 305.18\mu\text{V}$$

Digital Interface

The LTC2990 communicates with a bus master using a two-wire interface compatible with the I²C Bus and the SMBus, an I²C extension for low power devices.

The LTC2990 is a read-write slave device and supports SMBus bus Read Byte Data and Write Byte Data, Read Word Data and Write Word Data commands. The data formats for these commands are shown in Table 3 through Table 10.

The connected devices can only pull the bus wires LOW and can never drive the bus HIGH. The bus wires are externally connected to a positive supply voltage via a current source or pull-up resistor. When the bus is free, both lines are HIGH. Data on the I²C bus can be transferred at rates of up to 100kbit/s in the standard mode and up to 400kbit/s in the fast mode. Each device on the I²C bus is recognized by a unique address stored in that device and can operate as either a transmitter or receiver, depending on the function of the device. In addition to transmitters and receivers, devices can also be considered as masters or slaves when performing data transfers. A master is the device which initiates a data transfer on the bus and generates the clock signals to permit that transfer. At the same time any device addressed is considered a slave.

The LTC2990 can only be addressed as a slave. Once addressed, it can receive configuration bits or transmit the last conversion result. Therefore the serial clock line SCL is an input only and the data line SDA is bidirectional. The device supports the standard mode and the fast mode for data transfer speeds up to 400kbit/s. The Timing Diagram shows the definition of timing for fast/standard mode devices on the I²C bus. *The internal state machine cannot update internal data registers during an I²C read operation. The state machine pauses until the I²C read is complete. It is therefore, important not to leave*

the LTC2990 in this state for long durations, or increased conversion latency will be experienced.

START and STOP Conditions

When the bus is idle, both SCL and SDA must be high. A bus master signals the beginning of a transmission with a START condition by transitioning SDA from high to low while SCL is high. When the bus is in use, it stays busy if a repeated START (SR) is generated instead of a STOP condition. The repeated START (SR) conditions are functionally identical to the START (S). When the master has finished communicating with the slave, it issues a STOP condition by transitioning SDA from low to high while SCL is high. The bus is then free for another transmission.

I²C Device Addressing

Four distinct bus addresses are configurable using the ADR0-ADR1 pins. There is also one global sync address available at EEh which provides an easy way to synchronize multiple LTC2990s on the same I²C bus. This allows write only access to all 2990s on the bus for simultaneous triggering. Table 2 shows the correspondence between ADR0 and ADR1 pin states and addresses.

Acknowledge

The acknowledge signal is used for handshaking between the transmitter and the receiver to indicate that the last byte of data was received. The transmitter always releases the SDA line during the acknowledge clock pulse. When the slave is the receiver, it must pull down the SDA line so that it remains LOW during this pulse to acknowledge receipt of the data. If the slave fails to acknowledge by leaving SDA HIGH, then the master can abort the transmission by generating a STOP condition. When the master is receiving data from the slave, the master must pull down the SDA line during the clock pulse to indicate receipt of the data. After the last byte has been received the master will leave the SDA line HIGH (not acknowledge) and issue a STOP condition to terminate the transmission.

Write Protocol

The master begins communication with a START condition followed by the seven bit slave address and the R/W#

APPLICATIONS INFORMATION

bit set to zero. The addressed LTC2990 acknowledges the address and then the master sends a command byte which indicates which internal register the master wishes to write. The LTC2990 acknowledges the command byte and then latches the lower four bits of the command byte into its internal Register Address pointer. The master then delivers the data byte and the LTC2990 acknowledges once more and latches the data into its internal register. The transmission is ended when the master sends a STOP condition. If the master continues sending a second data byte, as in a Write Word command, the second data byte will be acknowledged by the LTC2990 and written to the next register in sequence, if this register has write access.

Read Protocol

The master begins a read operation with a START condition followed by the seven bit slave address and the R/W# bit set to zero. The addressed LTC2990 acknowledges this and then the master sends a command byte which indicates which internal register the master wishes to read. The LTC2990 acknowledges this and then latches the lower four bits of the command byte into its internal Register Address pointer. The master then sends a repeated START condition followed by the same seven bit address with the R/W# bit now set to one. The LTC2990 acknowledges and sends the contents of the requested register. The transmission is ended when the master sends a STOP condition. The register pointer is automatically incremented after each byte is read. If the master acknowledges the transmitted data byte, as in a Read Word command, the LTC2990 will send the contents

of the next sequential register as the second data byte. The byte following register 0x0F is register 0x00, or the status register.

Control Register

The control register (Table 5) determines the selected measurement mode of the device. The LTC2990 can be configured to measure voltages, currents and temperatures. These measurements can be single-shot or repeated measurements. Temperatures can be set to report in Celsius or Kelvin temperature scales. The LTC2990 can be configured to run particular measurements, or all possible measurements per the configuration specified by the mode bits. The power-on default configuration of the control register is set to 0x00, which translates to a repeated measurement of the internal temperature sensor, when triggered. This mode prevents the application of remote diode test currents on pins V1 and V3, and remote diode terminations on pins V2 and V4 at power-up.

Status Register

The status register (Table 4) reports the status of a particular conversion result. When new data is written into a particular result register, the corresponding DATA_VALID bit is set. When the register is addressed by the I²C interface, the status bit (as well as the DATA_VALID bit in the respective register) is cleared. The host can then determine if the current available register data is new or stale. The busy bit, when high, indicates a single-shot conversion is in progress. The busy bit is always high during repeated mode, after the initial conversion is triggered.

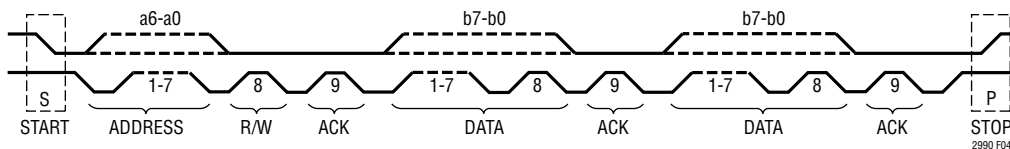

Figure 4. Data Transfer Over I²C or SMBus

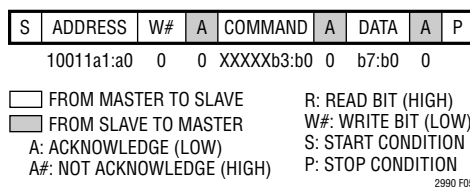

Figure 5. LTC2990 Serial Bus Write Byte Protocol

APPLICATIONS INFORMATION



Figure 6. LTC2990 Serial Bus Repeated Write Byte Protocol

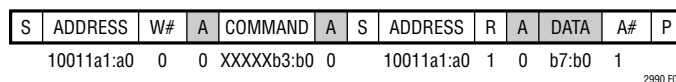

Figure 7. LTC2990 Serial Bus Read Byte Protocol

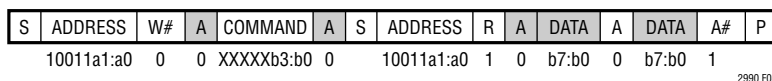

Figure 8. LTC2990 Serial Bus Repeated Read Byte Protocol

Table 2. I²C Base Address

HEX I ² C BASE ADDRESS	BINARY I ² C BASE ADDRESS	ADR1	ADR0
98h	1001 100X*	0	0
9Ah	1001 101X*	0	1
9Ch	1001 110X*	1	0
9Eh	1001 111X*	1	1
EEh	1110 1110	Global Sync Address	

*X = R/ \bar{W} Bit

Table 3. LTC2990 Register Address and Contents

REGISTER ADDRESS*†	REGISTER NAME	READ/WRITE	DESCRIPTION
00h	STATUS	R	Indicates BUSY State, Conversion Status
01h	CONTROL	R/W	Controls Mode, Single/Repeat, Celsius/Kelvin
02h	TRIGGER**	R/W	Triggers an Conversion
03h	N/A		Unused Address
04h	T _{INT} (MSB)	R	Internal Temperature MSB
05h	T _{INT} (LSB)	R	Internal Temperature LSB
06h	V1 (MSB)	R	V1, V1 – V2 or T _{R1} MSB
07h	V1 (LSB)	R	V1, V1 – V2 or T _{R1} LSB
08h	V2 (MSB)	R	V2, V1 – V2 or T _{R1} MSB
09h	V2 (LSB)	R	V2, V1 – V2 or T _{R1} LSB
0Ah	V3 (MSB)	R	V3, V3 – V4 or T _{R2} MSB
0Bh	V3 (LSB)	R	V3, V3 – V4 or T _{R2} LSB
0Ch	V4 (MSB)	R	V4, V3 – V4 or T _{R2} MSB
0Dh	V4 (LSB)	R	V4, V3 – V4 or T _{R2} LSB
0Eh	V _{CC} (MSB)	R	V _{CC} MSB
0Fh	V _{CC} (LSB)	R	V _{CC} LSB

*Register Address MSBs b7-b4 are ignored.

**Writing any value triggers a conversion. Data Returned reading this register address is the Status register.

†Power-on reset sets all registers to 00h.

APPLICATIONS INFORMATION

Table 4. STATUS Register (Default 0x00)

BIT	NAME	OPERATION
b7	0	Always Zero
b6	V _{CC} Ready	1 = V _{CC} Register Contains New Data, 0 = V _{CC} Register Read
b5	V4 Ready	1 = V4 Register Contains New Data, 0 = V4 Register Read
b4	V3, T _{R2} , V3 – V4 Ready	1 = V3 Register Contains New Data, 0 = V3 Register Data Old
b3	V2 Ready	1 = V2 Register Contains New Data, 0 = V2 Register Data Old
b2	V1, T _{R1} , V1 – V2 Ready	1 = V1 Register Contains New Data, 0 = V1 Register Data Old
b1	T _{INT} Ready	1 = T _{INT} Register Contains New Data, 0 = T _{INT} Register Data Old
b0	Busy*	1 = Conversion In Process, 0 = Acquisition Cycle Complete

*In Repeat mode, Busy = 1 always

Table 5. CONTROL Register (Default 0x00)

BIT	NAME	OPERATION		
b7	Temperature Format	Temperature Reported In; Celsius = 0 (Default), Kelvin = 1		
b6	Repeat/Single	Repeated Acquisition = 0 (Default), Single Acquisition = 1		
b5	Reserved	Reserved		
b[4:3]	Mode [4:3]	Mode Description		
	0	0	Internal Temperature Only (Default)	
	0	1	T _{R1} , V1 or V1 – V2 Only per Mode [2:0]	
	1	0	T _{R2} , V3 or V3 – V4 Only per Mode [2:0]	
	1	1	All Measurements per Mode [2:0]	
b[2:0]	Mode [2:0]	Mode Description		
	0	0	0	V1, V2, T _{R2} (Default)
	0	0	1	V1 – V2, T _{R2}
	0	1	0	V1 – V2, V3, V4
	0	1	1	T _{R1} , V3, V4
	1	0	0	T _{R1} , V3 – V4
	1	0	1	T _{R1} , T _{R2}
	1	1	0	V1 – V2, V3 – V4
1	1	1	V1, V2, V3, V4	

APPLICATIONS INFORMATION

Table 6. Voltage/Current Measurement MSB Data Register Format

BIT 7	BIT 6	BIT 5	BIT 4	BIT 3	BIT 2	BIT 1	BIT 0
DV*	Sign	D13	D12	D11	D10	D9	D8

*Data Valid is set when a new result is written into the register. Data Valid is cleared when this register is addressed (read) by the I²C interface.

Table 7. Voltage/Current Measurement LSB Data Register Format

BIT 7	BIT 6	BIT 5	BIT 4	BIT 3	BIT 2	BIT 1	BIT 0
D7	D6	D5	D4	D3	D2	D1	D0

Table 8. Temperature Measurement MSB Data Register Format

BIT 7	BIT 6	BIT 5	BIT 4	BIT 3	BIT 2	BIT 1	BIT 0
DV*	SS**	SO†	D12	D11	D10	D9	D8

*DATA_VALID is set when a new result is written into the register. DATA_VALID is cleared when this register is addressed (read) by the I²C interface.

**Sensor Short is high if the voltage measured on V1 is too low during temperature measurements. This signal is always low for T_{INT} measurements.

†Sensor Open is high if the voltage measured on V1 is excessive during temperature measurements. This signal is always low for T_{INT} measurements.

Table 9. Temperature Measurement LSB Data Register Format

BIT 7	BIT 6	BIT 5	BIT 4	BIT 3	BIT 2	BIT 1	BIT 0
D7	D6	D5	D4	D3	D2	D1	D0

APPLICATIONS INFORMATION

Table 10. Conversion Formats

VOLTAGE FORMATS	SIGN	BINARY VALUE D[13:0]	VOLTAGE
Single-Ended LSB = 305.18 μ V	0	11111111111111	>5
	0	10110011001101	3.500
	0	01111111111111	2.500
	0	00000000000000	0.000
	1	11110000101001	-0.300
Differential LSB = 19.42 μ V	0	11111111111111	>0.318
	0	11110001011000	+0.300
	0	10000000000000	+0.159
	0	00000000000000	0.000
	1	10000000000000	-0.159
	1	00001110101000	-0.300
V_{CC} = Result + 2.5V LSB = 305.18 μ V	0	10110011001101	V_{CC} = 6V
	0	10000000000000	V_{CC} = 5V
	0	00001010001111	V_{CC} = 2.7V
TEMPERATURE FORMATS	FORMAT	BINARY VALUE D[12:0]	TEMPERATURE
Temperature Internal, T_{R1} or T_{R2} LSB = 0.0625 Degrees	Celsius	0011111010000	+125.0000
	Celsius	0000110010001	+25.0625
	Celsius	0000110010000	+25.0000
	Celsius	1110110000000	-40.0000
	Kelvin	1100011100010	398.1250
	Kelvin	1000100010010	273.1250
	Kelvin	0111010010010	233.1250

TYPICAL APPLICATIONS

Motor Protection/Regulation

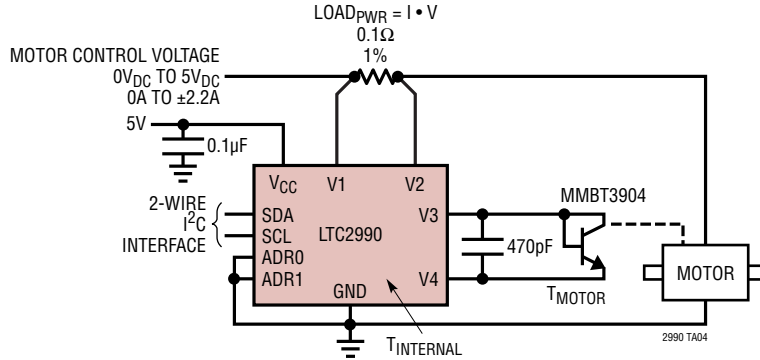

CURRENT AND TEMPERATURE CONFIGURATION:

CONTROL REGISTER: 0x59		
T_{AMB}	REG 4, 5	0.0625°C/LSB
I_{MOTOR}	REG 6, 7	194µA/LSB
T_{MOTOR}	REG A, B	0.0625°C/LSB
V_{CC}	REG E, F	2.5V + 305.18µV/LSB

VOLTAGE AND TEMPERATURE CONFIGURATION:

CONTROL REGISTER: 0x58		
T_{AMB}	REG 4, 5	0.0625°C/LSB
V_{MOTOR}	REG 8, 9	305.18µV/LSB
T_{MOTOR}	REG A, B	0.0625°C/LSB
V_{CC}	REG E, F	2.5V + 305.18µV/LSB

Large Motor Protection/Regulation

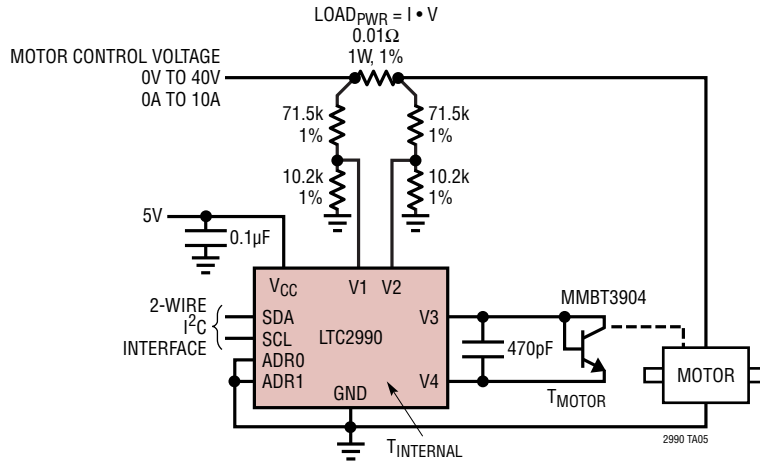

VOLTAGE AND TEMPERATURE CONFIGURATION:

CONTROL REGISTER: 0x58		
T_{AMB}	REG 4, 5	0.0625°C/LSB
V_{MOTOR}	REG 8, 9	2.44mV/LSB
T_{MOTOR}	REG A, B	0.0625°C/LSB
V_{CC}	REG E, F	2.5V + 305.18µV/LSB

CURRENT AND TEMPERATURE CONFIGURATION:

CONTROL REGISTER: 0x59		
T_{AMB}	REG 4, 5	0.0625°C/LSB
I_{MOTOR}	REG 6, 7	15.54mA/LSB
T_{MOTOR}	REG A, B	0.0625°C/LSB
V_{CC}	REG E, F	2.5V + 305.18µV/LSB

TYPICAL APPLICATIONS

Wet-Bulb Psychrometer

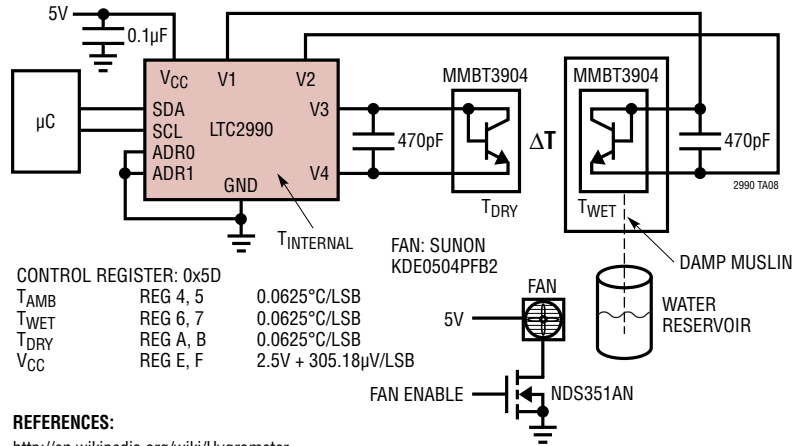

Wind Direction/Instrumentation

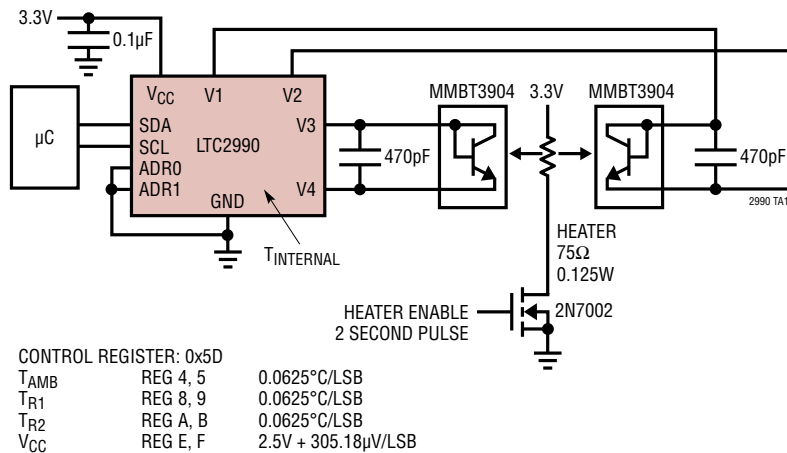

TYPICAL APPLICATIONS

Liquid-Level Indicator

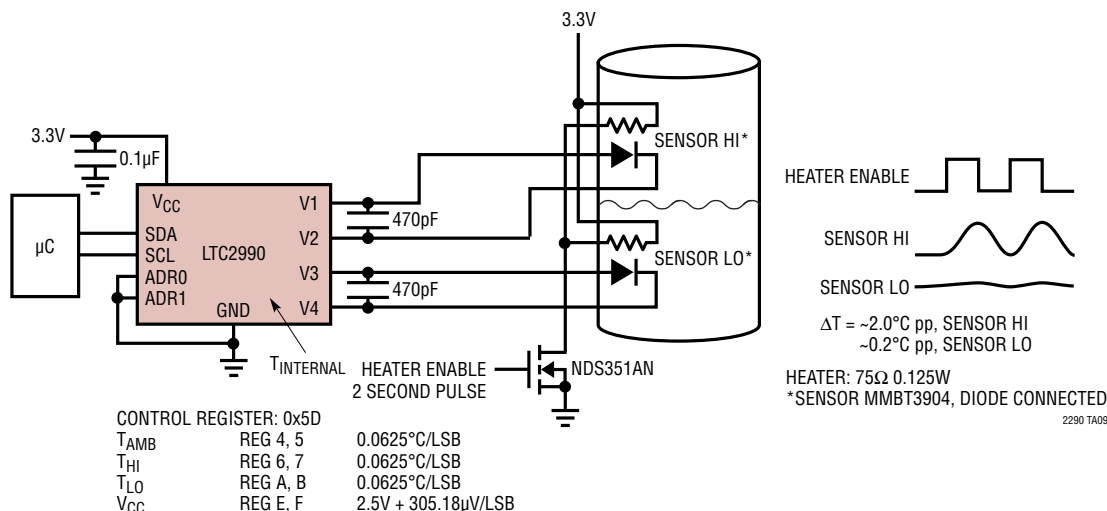

Oscillator/Reference Oven Temperature Regulation

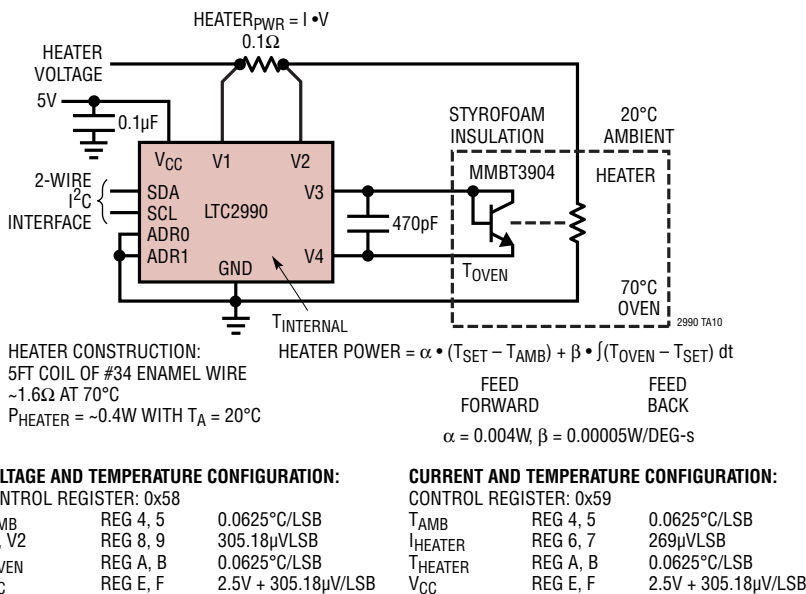

REVISION HISTORY

REV	DATE	DESCRIPTION	PAGE NUMBER
A	6/11	Revised title of data sheet from "I ² C Temperature, Voltage and Current Monitor"	1
		Revised Conditions and Values under Measurement Accuracy in Electrical Characteristics section	2
		Revised curve G05 labels in Typical Performance Characteristics section	4
		Revised Applications Information section and renumbered tables and table references	9 to 17
B	8/11	Updated Features section	1
		Updated Current Measurements section	10
		Updated Related Parts	24
C	12/11	Removed conditions for V _{CC(TUE)} in Electrical Characteristics	2
		Updated Pin 8 description	6
		Removed ° symbol in reference to Kelvin measurements	9
		Revised Current Measurements, Voltage/Current, I ² C Device Addressing, Table 2, Table 5, and Table 10 in Applications Information	10, 11, 12, 14, 15, 17
		Revised Typical Applications drawings TA05 and TA11	19, 20
D	7/14	Revised Device Configuration section	11
		Updated MSOP Package Description	22
E	11/16	Added V _{OFFSET_DIFF} and V _{OFFSET_SE} to the Electrical Characteristics section	3
F	11/18	Corrected current register equations	13
		Corrected differential voltage = +0.300 binary value	18

TYPICAL APPLICATION

High Voltage/Current and Temperature Monitoring

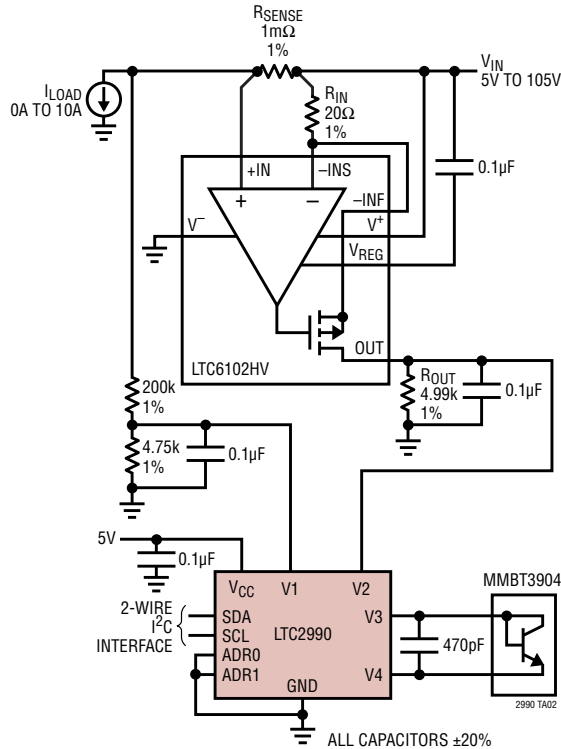

VOLTAGE, CURRENT AND TEMPERATURE CONFIGURATION:

CONTROL REGISTER: 0x58

T_{AMB}	REG 4, 5	0.0625°C/LSB
V_{LOAD}	REG 6, 7	13.2mV/LSB
$V2(I_{LOAD})$	REG 8, 9	1.223mA/LSB
T_{REMOTE}	REG A, B	0.0625°C/LSB
V_{CC}	REG E, F	2.5V + 305.18µV/LSB

RELATED PARTS

PART NUMBER	DESCRIPTION	COMMENTS
LTC2991	Octal I ² C Voltage, Current, Temperature Monitor	Remote and Internal Temperatures, 14-Bit Voltages and Current, Internal 10ppm/°C Reference
LTC2997	Remote/Internal Temperature Sensor	Temperature to Voltage with Integrated 1.8V Voltage Reference, ±1°C Accuracy
LM134	Constant Current Source and Temperature Sensor	Can Be Used as Linear Temperature Sensor
LTC1392	Micropower Temperature, Power Supply and Differential Voltage Monitor	Complete Ambient Temperature Sensor Onboard
LTC2487	16-Bit, 2-/4-Channel Delta Sigma ADC with PGA, Easy Drive™ and I ² C Interface	Internal Temperature Sensor
LTC6102/LTC6102HV	Precision Zero Drift Current Sense Amplifier	5V to 100V, 105V Absolute Maximum (LTC6102HV)
LTC2983	Multi-Sensor High Accuracy Digital Temperature Measurement System	20 Channels Measure Any Combination of Thermocouples, RTDs, Thermistors and Diodes
LTC2984	Multi-Sensor High Accuracy Digital Temperature Measurement System with EEPROM	20 Channels Measure Any Combination of Thermocouples, RTDs, Thermistors and Diodes
LTC2986	Multi-Sensor High Accuracy Digital Temperature Measurement System with EEPROM	10 Channels Measure Any Combination of Thermocouples, RTDs, Thermistors and Diodes

Looking for pricing, stock, or lifecycle information?

Click below to explore more details on WIN SOURCE:

 [View LTC2990IMS#PBF](#) on WIN SOURCE

 [Linear Technology](#) Information

Optimize Your Supply Chain with WIN SOURCE Solutions

-  Global Sourcing Solution
-  Obsolete Management
-  Cost Control Management
-  Shortage Management
-  Alternative Solution
-  Excess Inventory Management