



**THE DATASHEET OF
LMV116MF/NOPB**



LMV11x Low-Voltage, 45-MHz, Rail-To-Rail Output Operational Amplifiers With Shutdown Option

1 Features

- –3-dB BW 45 MHz
- Supply Voltage Range 2.7 V to 12 V
- Slew Rate 40 V/ μ s
- Supply Current 600 μ A
- Power Down Supply Current 15 μ A
- Output Short Circuit Current 32 mA
- Linear Output Current \pm 20 mA
- Input Common Mode Voltage –0.3 V to 1.7 V
- Output Voltage Swing 20 mV from Rails
- Input Voltage Noise 40 nV/ $\sqrt{\text{Hz}}$
- Input Current Noise 0.75 pA/ $\sqrt{\text{Hz}}$

2 Applications

- High-Speed Clock Buffer/Driver
- Active Filters
- High-Speed Portable Devices
- Multiplexing Applications (LMV118)
- Current Sense Amplifier
- High-Speed Transducer Amplifier

3 Description

The LMV116 (single) rail-to-rail output voltage feedback amplifiers offer high-speed (45 MHz), and low-voltage operation (2.7 V) in addition to micro-power shutdown capability (LMV118).

Output voltage range extends to within 20 mV of either supply rail, allowing wide dynamic range especially in low voltage applications. Even with low supply current of 600 μ A, output current capability is kept at a respectable \pm 20 mA for driving heavier loads. Important device parameters such as BW, slew rate, and output current are kept relatively independent of the operating supply voltage by a combination of process enhancements and design architecture.

For portable applications, the LMV118 provides shutdown capability while keeping the turnoff current to 15 μ A. Both turnon and turnoff characteristics are well behaved with minimal output fluctuations during transitions, thus the device can be used in power-saving mode, as well as multiplexing applications. Miniature packages (5-pin and 6-pin SOT-23) are further means to ease the adoption of these low-power, high-speed devices in applications where board area is at a premium.

Device Information⁽¹⁾

PART NUMBER	PACKAGE	BODY SIZE (NOM)
LMV116	SOT-23 (5)	2.90 mm x 1.60 mm
	SOT-23 (6)	2.90 mm x 1.60 mm
LMV118	SOT-23 (5)	2.90 mm x 1.60 mm
	SOT-23 (6)	2.90 mm x 1.60 mm

(1) For all available packages, see the orderable addendum at the end of the data sheet.

Typical Application

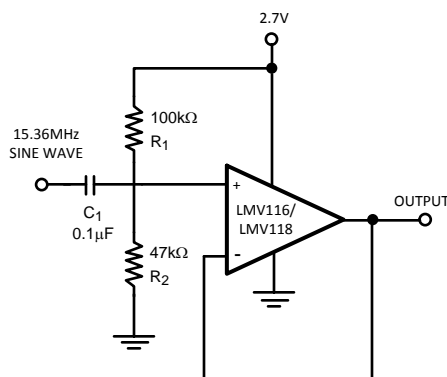

Table of Contents

1 Features	1	7.4 Device Functional Modes.....	13
2 Applications	1	8 Application and Implementation	15
3 Description	1	8.1 Application Information.....	15
4 Revision History	2	8.2 Typical Application: 2.7-V Single Supply 2:1 MUX	15
5 Pin Configuration and Functions	3	9 Power Supply Recommendations	16
6 Specifications	4	10 Layout	17
6.1 Absolute Maximum Ratings	4	10.1 Layout Guidelines	17
6.2 ESD Ratings.....	4	10.2 Layout Example	17
6.3 Recommended Operating Conditions.....	4	11 Device and Documentation Support	18
6.4 Thermal Information	4	11.1 Related Documentation.....	18
6.5 Electrical Characteristics: 2.7 V	5	11.2 Related Links	18
6.6 Electrical Characteristics: 5 V	6	11.3 Receiving Notification of Documentation Updates	18
6.7 Electrical Characteristics: ± 5 V	7	11.4 Community Resources.....	18
6.8 Typical Characteristics.....	8	11.5 Trademarks	18
7 Detailed Description	12	11.6 Electrostatic Discharge Caution.....	18
7.1 Overview	12	11.7 Glossary	18
7.2 Functional Block Diagram	12	12 Mechanical, Packaging, and Orderable	18
7.3 Feature Description.....	12	Information	18

4 Revision History

NOTE: Page numbers for previous revisions may differ from page numbers in the current version.

Changes from Revision B (May 2013) to Revision C	Page
<ul style="list-style-type: none"> Added <i>Device Information</i> and <i>Pin Configuration and Functions</i> sections, <i>ESD Ratings</i> and <i>Thermal Information</i> tables, <i>Functional Block Diagram</i>, <i>Feature Description</i>, <i>Device Functional Modes</i>, <i>Application and Implementation</i>, <i>Power Supply Recommendations</i>, <i>Layout</i>, <i>Device and Documentation Support</i>, and <i>Mechanical, Packaging, and Orderable Information</i> sections 	1
<ul style="list-style-type: none"> Changed $R_{\theta JA}$ from 265°C/W to 182.7°C/W 	4

Changes from Revision A (May 2013) to Revision B	Page
<ul style="list-style-type: none"> Changed layout of National Semiconductor data sheet to TI format..... 	17

5 Pin Configuration and Functions

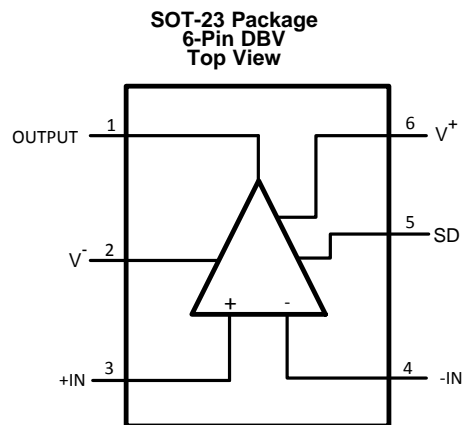
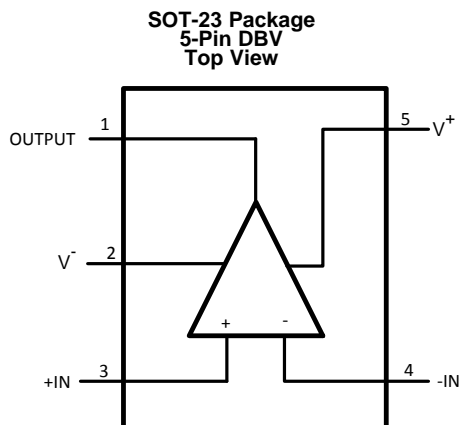

Pin Functions

NAME	PIN		I/O	DESCRIPTION
	LMV116	LMV118		
+IN	3	3	Input	Non-inverting input
-IN	4	4	Input	Inverting input
OUTPUT	1	1	Output	Output
SD	—	5	Input	Shutdown input. Active high, must be tied to V- with resistor for normal operation.
V+	5	6	Power	Positive (highest) power supply
V-	2	2	Power	Negative (lowest) power supply

6 Specifications

6.1 Absolute Maximum Ratings

 over operating free-air temperature range (unless otherwise noted)⁽¹⁾⁽²⁾

		MIN	MAX	UNIT
Supply voltage (V ⁺ - V ⁻)			12.6	V
Voltage at INPUT and OUTPUT pins		V ⁻ -0.8	V ⁺ + 0.8	V
Output short-circuit duration		See ^{(3), (4)}		
Junction temperature ⁽⁵⁾			150	°C
Soldering information	Infrared or convection (20 seconds)		235	°C
	Wave soldering lead temperature (10 seconds)		260	°C
Storage temperature, T _{stg}		-65	150	°C

- Stresses beyond those listed under *Absolute Maximum Ratings* may cause permanent damage to the device. These are stress ratings only, which do not imply functional operation of the device at these or any other conditions beyond those indicated under *Recommended Operating Conditions*. Exposure to absolute-maximum-rated conditions for extended periods may affect device reliability.
- If Military/Aerospace specified devices are required, contact the TI Sales Office/ Distributors for availability and specifications.
- Applies to both single-supply and split-supply operation. Continuous short circuit operation at elevated ambient temperature can result in exceeding the maximum allowed junction temperature of 150°C.
- Output short circuit duration is infinite for V_S < 6 V at room temperature and below. For V_S > 6 V, allowable short circuit duration is 1.5 ms.
- The maximum power dissipation is a function of T_{J(MAX)}, R_{θJA}, and T_A. The maximum allowable power dissipation at any ambient temperature is P_D = (T_{J(MAX)} - T_A) / R_{θJA}. All numbers apply for packages soldered directly onto a PC board.

6.2 ESD Ratings

		VALUE	UNIT
V _(ESD) Electrostatic discharge	Human-body model (HBM), per ANSI/ESDA/JEDEC JS-001 ⁽¹⁾	±2000	V
	Machine model	±200	

- JEDEC document JEP155 states that 500-V HBM allows safe manufacturing with a standard ESD control process.

6.3 Recommended Operating Conditions

over operating free-air temperature range (unless otherwise noted)

		MIN	NOM	MAX	UNIT
Supply voltage (V ⁺ - V ⁻)		2.5		12	V
Temperature ⁽¹⁾		-40		85	°C

- The maximum power dissipation is a function of T_{J(MAX)}, R_{θJA}, and T_A. The maximum allowable power dissipation at any ambient temperature is P_D = (T_{J(MAX)} - T_A) / R_{θJA}. All numbers apply for packages soldered directly onto a PC board.

6.4 Thermal Information

THERMAL METRIC ⁽¹⁾		LMV116	LMV118	UNIT
		DBV (SOT-23)	DBV (SOT-23)	
		5 PINS	6 PINS	
R _{θJA}	Junction-to-ambient thermal resistance	182.7	182.7	°C/W
R _{θJC(top)}	Junction-to-case (top) thermal resistance	139.9	139.9	°C/W
R _{θJB}	Junction-to-board thermal resistance	41.4	41.4	°C/W
ψ _{JT}	Junction-to-top characterization parameter	28.5	28.5	°C/W
ψ _{JB}	Junction-to-board characterization parameter	40.9	40.9	°C/W

- For more information about traditional and new thermal metrics, see [Semiconductor and IC Package Thermal Metrics](#).

6.5 Electrical Characteristics: 2.7 V

Unless otherwise specified, all limits apply for $T_J = 25^\circ\text{C}$, $V^+ = 2.7\text{ V}$, $V^- = 0\text{ V}$, $V_{\text{CM}} = V_O = V^+ / 2$, and $R_F = 2\text{ k}\Omega$, and $R_L = 1\text{ k}\Omega$ to $V^+ / 2$.

PARAMETER		TEST CONDITIONS	MIN ⁽¹⁾	TYP ⁽²⁾	MAX ⁽¹⁾	UNIT
V _{OS}	Input offset voltage	$0\text{ V} \leq V_{\text{CM}} \leq 1.7\text{ V}$		±1	±5	mV
		$0\text{ V} \leq V_{\text{CM}} \leq 1.7\text{ V}$ –40°C to 85°C			±6	
TC V _{OS}	Input offset average drift	See ⁽³⁾		±5		µV/C
I _B	Input bias current	See ⁽⁴⁾	–2	–0.4		µA
		See ⁽⁴⁾ , –40°C to 85°C	–2.2			
I _{OS}	Input offset current			1	500	nA
CMRR	Common mode rejection ratio	V _{CM} stepped from 0 V to 1.55 V	73	88		dB
PSRR	Power supply rejection ratio	V ⁺ = 2.7 V to 3.7 V or V [–] = 0 V to –1 V	72	85		dB
R _{IN}	Common mode input resistance			3		MΩ
C _{IN}	Common mode input capacitance			2		pF
CMVR	Input common-mode voltage range	CMRR ≥ 50 dB	–0.3		1.7	V
		CMRR ≥ 50 dB, –40°C to 85°C	–0.1			
A _{VOL}	Large signal voltage gain	V _O = 0.35 V to 2.35 V	73	87		dB
		V _O = 0.35 V to 2.35 V, –40°C to 85°C	70			
V _O	Output swing high	R _L = 1 kΩ to V ⁺ /2	2.55	2.66		V
		R _L = 10 kΩ to V ⁺ /2		2.68		
	Output swing low	R _L = 1 kΩ to V ⁺ /2	150	40		mV
		R _L = 10 kΩ to V ⁺ /2		20		
I _{SC}	Output short-circuit current	Sourcing to V [–] V _{ID} = 200 mV ⁽⁵⁾	25	35		mA
		Sinking to V ⁺ V _{ID} = –200 mV ⁽⁵⁾	25	32		
I _{OUT}	Output current	V _{OUT} = 0.5 V from rails		±20		mA
I _S	Supply current	Normal operation		600	900	µA
		Shutdown mode (LMV118)		15	50	
SR	Slew rate ⁽⁶⁾	A _V = +1, V _O = 1 V _{PP}		40		V/µs
BW	–3 dB BW	A _V = +1, V _{OUT} = 200 mV _{PP}		45		MHz
e _n	Input-referred voltage noise	f = 100 kHz		40		nV/√Hz
		f = 1 kHz		60		
i _n	Input-referred current noise	f = 100 kHz		0.75		pA/√Hz
		f = 1 kHz		1.2		
t _{on}	Turnon time (LMV118)			250		ns
t _{off}	Turnoff time (LMV118)			560		ns
TH _{SD}	Shutdown threshold (LMV118)	I _S ≤ 50 µA		1.95	2.3	V
I _{SD}	SHUTDOWN pin input current (LMV118)	See ⁽⁴⁾		–20		µA

(1) All limits are specified by testing or statistical analysis.

(2) Typical values represent the most likely parametric norm.

(3) Offset voltage average drift determined by dividing the change in V_{OS} at temperature extremes into the total temperature change.

(4) Positive current corresponds to current flowing into the device.

(5) Short-circuit test is a momentary test. See [Absolute Maximum Ratings](#), note 4.

(6) Slew rate is the average of the rising and falling slew rates.

6.6 Electrical Characteristics: 5 V

Unless otherwise specified, all limits apply for $T_J = 25^\circ\text{C}$, $V^+ = 5\text{ V}$, $V^- = 0\text{ V}$, $V_{\text{CM}} = V_O = V^+/2$, and $R_F = 2\text{ k}\Omega$, and $R_L = 1\text{ k}\Omega$ to $V^+/2$.

PARAMETER		TEST CONDITIONS	MIN ⁽¹⁾	TYP ⁽²⁾	MAX ⁽¹⁾	UNIT
V _{OS}	Input offset voltage	$0\text{ V} \leq V_{\text{CM}} \leq 1.7\text{ V}$		±1	±5	mV
		$0\text{ V} \leq V_{\text{CM}} \leq 1.7\text{ V}$ –40°C to 85°C			±6	
TC V _{OS}	Input offset average drift	See ⁽³⁾		±5		µV/C
I _B	Input bias current	See ⁽⁴⁾	–2	–0.4		µA
		See ⁽⁴⁾ , –40°C to 85°C	–2.2			
I _{OS}	Input offset current			1	500	nA
CMRR	Common mode rejection ratio	V _{CM} stepped from 0 V to 3.8 V	77	85		dB
PSRR	Power supply rejection ratio	V ⁺ = 5 V to 6 V or V [–] = 0 V to –1 V	72	95		dB
R _{IN}	Common mode input resistance			3		MΩ
C _{IN}	Common mode input capacitance			2		pF
CMVR	Input common-mode voltage range	CMRR ≥ 50 dB	–0.3		4	V
		CMRR ≥ 50 dB, –40°C to 85°C	–0.1			
A _{VOL}	Large signal voltage gain	V _O = 1.5 V to 3.5 V	73	87		dB
		V _O = 1.5 V to 3.5 V, –40°C to 85°C	70			
V _O	Output swing high	R _L = 1 kΩ to V ⁺ /2	4.8	4.95		V
		R _L = 10 kΩ to V ⁺ /2		4.98		
	Output swing low	R _L = 1 kΩ to V ⁺ /2	200	50		mV
		R _L = 10 kΩ to V ⁺ /2		20		
I _{SC}	Output short-circuit current	Sourcing to V [–] V _{ID} = 200 mV ⁽⁵⁾	35	45		mA
		Sinking to V ⁺ V _{ID} = –200 mV ⁽⁵⁾	35	43		
I _{OUT}	Output current	V _{OUT} = 0.5 V from rails		±20		mA
I _S	Supply current	Normal operation		600	900	µA
		Shutdown mode (LMV118)		10	50	
SR	Slew rate ⁽⁶⁾	A _V = +1, V _O = 1 V _{PP}		40		V/µs
BW	–3 dB BW	A _V = +1, V _{OUT} = 200 mV _{PP}		45		MHz
e _n	Input-referred voltage noise	f = 100 kHz		40		nV/√Hz
		f = 1 kHz		60		
i _n	Input-referred current noise	f = 100 kHz		0.75		pA/√Hz
		f = 1 kHz		1.2		
t _{on}	Turnon time (LMV118)			210		ns
t _{off}	Turnoff time (LMV118)			500		ns
TH _{SD}	Shutdown threshold (LMV118)	I _S ≤ 50 µA		4.25	4.6	V
I _{SD}	SHUTDOWN pin input current (LMV118)	See ⁽⁴⁾		–20		µA

- (1) All limits are specified by testing or statistical analysis.
- (2) Typical values represent the most likely parametric norm.
- (3) Offset voltage average drift determined by dividing the change in V_{OS} at temperature extremes into the total temperature change.
- (4) Positive current corresponds to current flowing into the device.
- (5) Short-circuit test is a momentary test. See [Absolute Maximum Ratings](#), note 4.
- (6) Slew rate is the average of the rising and falling slew rates.

6.7 Electrical Characteristics: ± 5 V

Unless otherwise specified, all limits apply for $T_J = 25^\circ\text{C}$, $V^+ = 5$ V, $V^- = -5$ V, $V_{CM} = V_O = 0$ V, and $R_F = 2$ k Ω , and $R_L = 1$ k Ω to $V^+/2$.

PARAMETER		TEST CONDITIONS	MIN ⁽¹⁾	TYP ⁽²⁾	MAX ⁽¹⁾	UNIT
V _{OS}	Input offset voltage	$0\text{ V} \leq V_{CM} \leq 1.7\text{ V}$		± 1	± 5	mV
		$0\text{ V} \leq V_{CM} \leq 1.7\text{ V}$ -40°C to 85°C			± 6	
TC V _{OS}	Input offset average drift	See ⁽³⁾		± 5		$\mu\text{V}/\text{C}$
I _B	Input bias current	See ⁽⁴⁾	-2	-0.4		μA
		See ⁽⁴⁾ , -40°C to 85°C	-2.2			
I _{OS}	Input offset current			3	500	nA
CMRR	Common mode rejection ratio	V_{CM} stepped from 0 V to 3.8 V	78	104		dB
PSRR	Power supply rejection ratio	$V^+ = 5$ V to 6 V or $V^- = 0$ V to -1 V	72	95		dB
R _{IN}	Common mode input resistance			3		M Ω
C _{IN}	Common mode input capacitance			2		pF
CMVR	Input common-mode voltage range	CMRR ≥ 50 dB	-5.3		4	V
		CMRR ≥ 50 dB, -40°C to 85°C	-5.1			
A _{VOL}	Large signal voltage gain	$V_O = 1.5$ V to 3.5 V	74	85		dB
		$V_O = 1.5$ V to 3.5 V, -40°C to 85°C	71			
V _O	Output swing high	$R_L = 1$ k Ω to $V^+/2$	4.7	4.92		V
		$R_L = 10$ k Ω to $V^+/2$		4.97		
	Output swing low	$R_L = 1$ k Ω to $V^+/2$	-4.7	-4.92		V
		$R_L = 10$ k Ω to $V^+/2$		-4.98		
I _{SC}	Output short-circuit current	Sourcing to V^- $V_{ID} = 200$ mV ⁽⁵⁾	40	57		mA
		Sinking to V^+ $V_{ID} = -200$ mV ⁽⁵⁾	40	54		
I _{OUT}	Output current	$V_{OUT} = 0.5$ V from rails		± 20		mA
I _S	Supply current	Normal operation		600	900	μA
		Shutdown mode (LMV118)		15	50	
SR	Slew rate ⁽⁶⁾	$A_V = 1$, $V_O = 1$ V _{PP}		35		V/ μs
BW	-3 dB BW	$A_V = 1$, $V_{OUT} = 200$ mV _{PP}		45		MHz
e _n	Input-referred voltage noise	$f = 100$ kHz		40		nV/ $\sqrt{\text{Hz}}$
		$f = 1$ kHz		60		
i _n	Input-referred current noise	$f = 100$ kHz		0.75		pA/ $\sqrt{\text{Hz}}$
		$f = 1$ kHz		1.2		
t _{on}	Turnon time (LMV118)			200		ns
t _{off}	Turnoff time (LMV118)			700		ns
TH _{SD}	Shutdown threshold (LMV118)	$I_S \leq 50$ μA		4.25	4.6	V
I _{SD}	SHUTDOWN pin input current (LMV118)	See ⁽⁴⁾		-20		μA

- (1) Typical values represent the most likely parametric norm.
- (2) Offset voltage average drift determined by dividing the change in V_{OS} . All limits are specified by testing or statistical analysis.
- (3) at temperature extremes into the total temperature change.
- (4) Positive current corresponds to current flowing into the device.
- (5) Short-circuit test is a momentary test. See [Absolute Maximum Ratings](#), note 4.
- (6) Slew rate is the average of the rising and falling slew rates.

LMV116, LMV118

SNOSA87C – OCTOBER 2003 – REVISED OCTOBER 2016

www.ti.com

6.8 Typical Characteristics

At $T_J = 25^\circ\text{C}$. Unless otherwise specified.

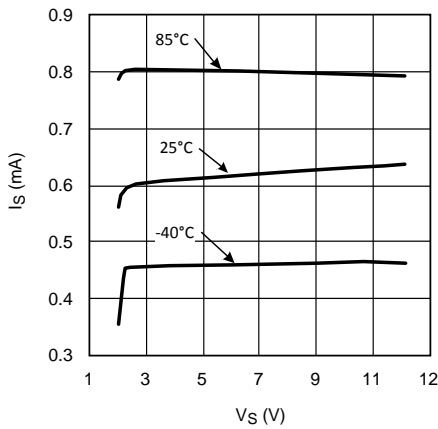

Figure 1. Supply Current vs Supply Voltage

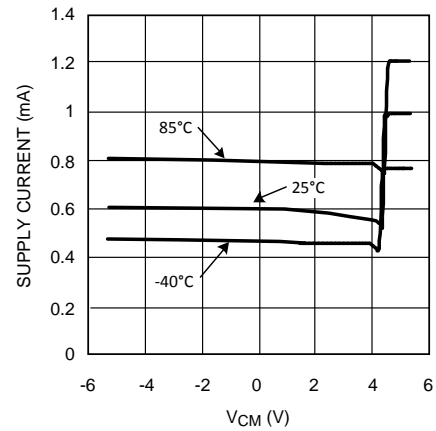

Figure 2. Supply Current vs V_{CM}

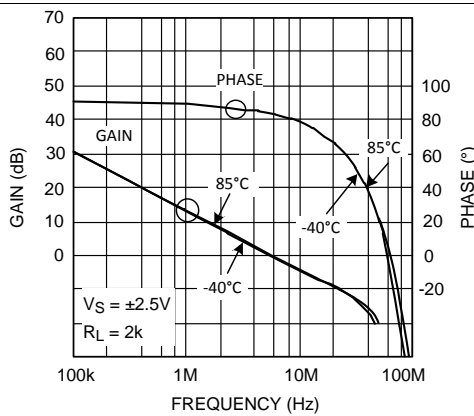

Figure 3. Gain and Phase vs Frequency

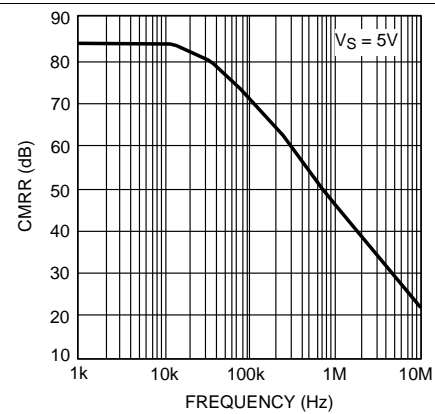

Figure 4. CMRR vs Frequency

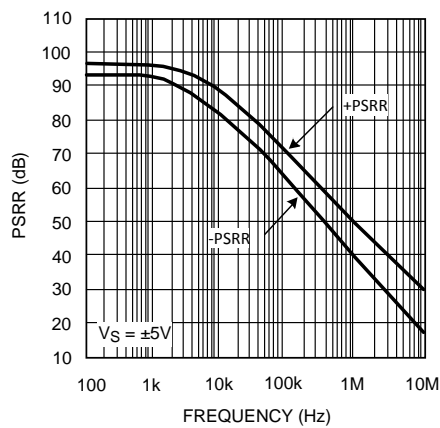

Figure 5. PSRR vs Frequency

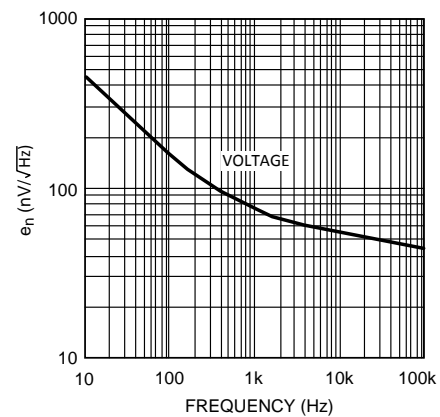

Figure 6. Input Voltage Noise vs Frequency

Typical Characteristics (continued)

At $T_J = 25^\circ\text{C}$. Unless otherwise specified.

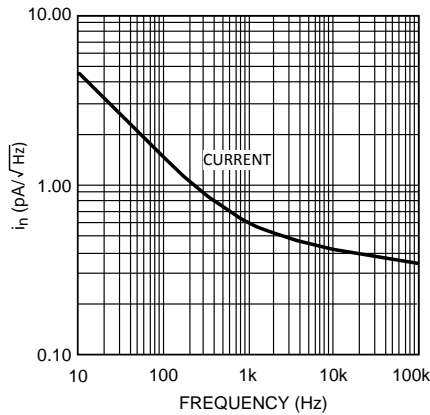

Figure 7. Input Current Noise vs Frequency

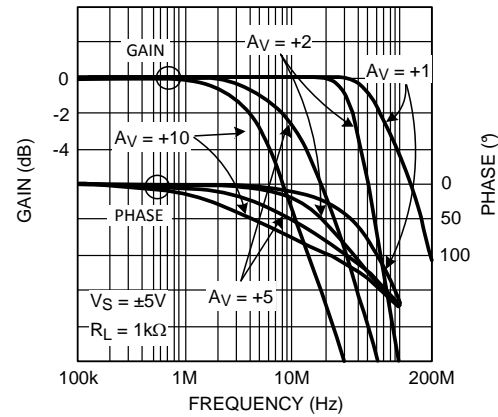

Figure 8. Closed-Loop Frequency Response for Various Temperature

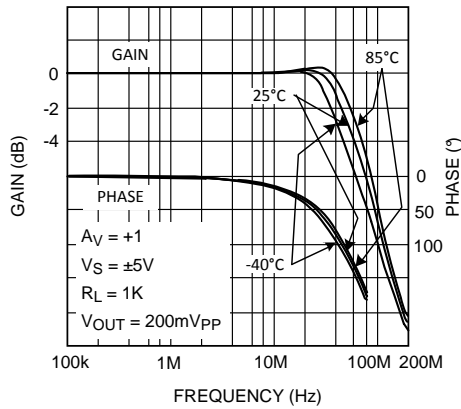

Figure 9. Frequency Response For Various (A_v)

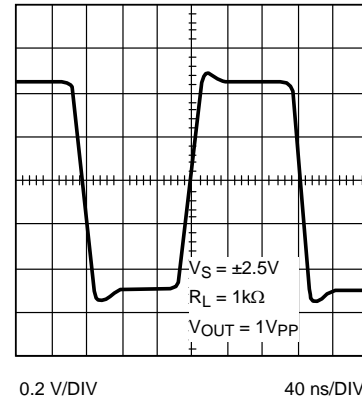

Figure 10. Large Signal Step Response

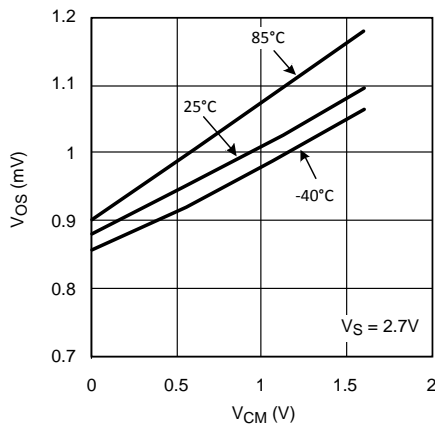

Figure 11. Offset Voltage vs Common Mode Voltage (a Typical Unit)

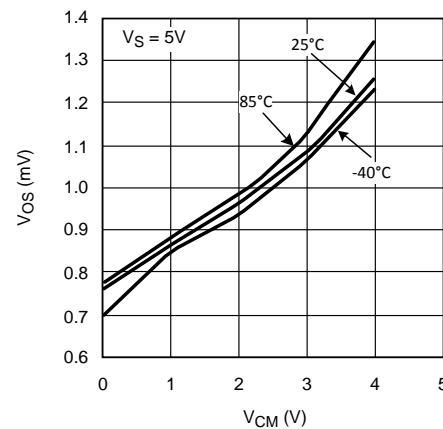

Figure 12. Offset Voltage vs Common Mode Voltage (a Typical Unit)

Typical Characteristics (continued)

At $T_J = 25^\circ\text{C}$. Unless otherwise specified.

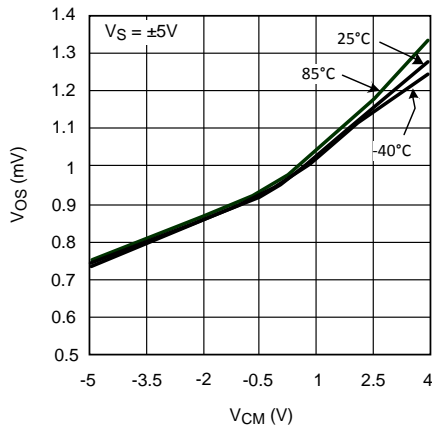

Figure 13. Offset Voltage vs Common Mode Range (a Typical Unit)

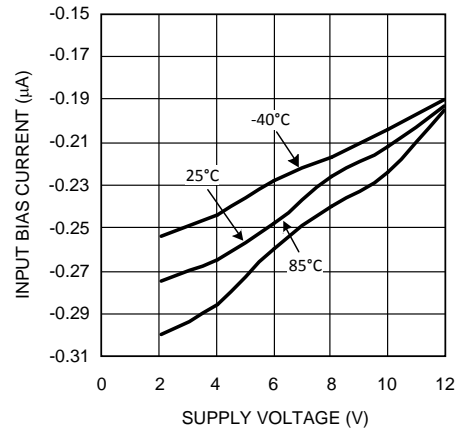

Figure 14. Input Bias Current vs Supply Voltage

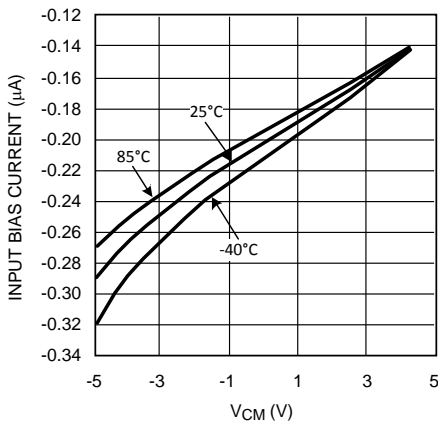

Figure 15. Input Bias Current vs V_{CM}

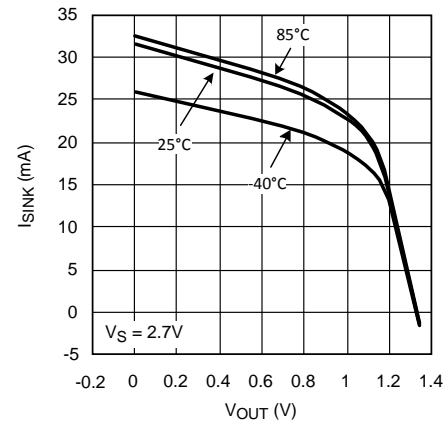

Figure 16. Sink Current vs V_{OUT}

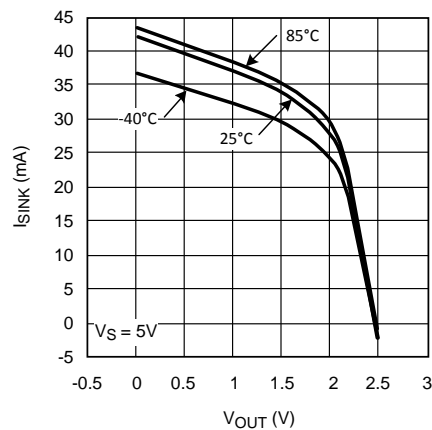

Figure 17. Sink Current vs V_{OUT}

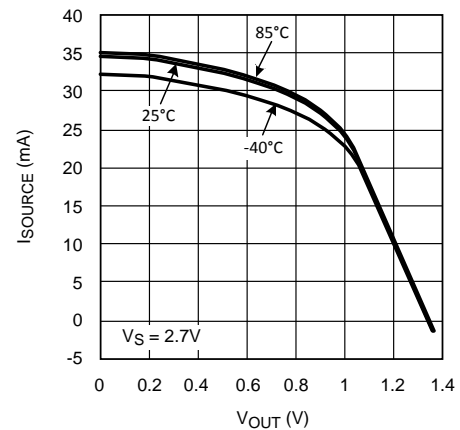

Figure 18. Source Current vs V_{OUT}

Typical Characteristics (continued)

At $T_J = 25^\circ\text{C}$. Unless otherwise specified.

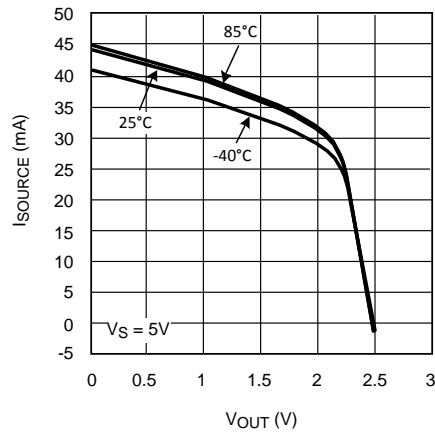

Figure 19. Source Current vs V_{OUT}

7 Detailed Description

7.1 Overview

The LMV116 and LMV118 are based on TI's proprietary VIP10 dielectrically isolated bipolar process.

The LMV116 and LMV118 architecture features the following:

- Complementary bipolar devices with exceptionally high f_t (approximately 8 GHz) even under low supply voltage (2.7 V) and low collector bias current.
- Common emitter push-pull output stage capable of 20-mA output current (at 0.5 V from the supply rails) while consuming only 600 μA of total supply current. This architecture allows output to reach within milli-volts of either supply rail at light loads.
- Consistent performance from any supply voltage (2.7 V to 10 V) with little variation with supply voltage for the most important specifications (for example, BW, SR, I_{OUT} , etc.)

7.2 Functional Block Diagram

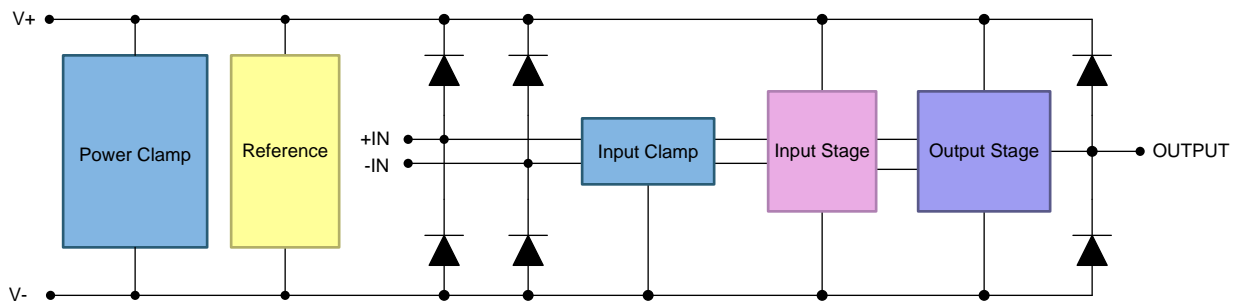

Copyright © 2016, Texas Instruments Incorporated

7.3 Feature Description

The amplifier's differential inputs consist of a non-inverting input (+IN) and an inverting input (–IN). The amplifier amplifies only the difference in voltage between the two inputs, which is called the differential input voltage. The output voltage of the op-amp V_{OUT} is given by [Equation 1](#):

$$V_{\text{OUT}} = A_{\text{VOL}} (+\text{IN} - -\text{IN})$$

where

- A_{VOL} is the open-loop gain of the amplifier, typically around 85 dB. (1)

7.4 Device Functional Modes

7.4.1 Quasi-Saturated State

When the output swing approaches either supply rail, the output transistor enters a quasi-saturated state. A subtle effect of this operational region is that there is an increase in supply current in this state (up to 1 mA). The onset of quasi-saturation region is a function of output loading (current) and varies from 100 mV at no load to about 1 V when output is delivering 20 mA, as measured from supplies. Both input common mode voltage and output voltage level affect the supply current (see [Typical Characteristics](#) for plot).

7.4.2 Micro-Power Shutdown

The LMV118 can be shut down to save power and reduce its supply current to less than the 50 μ A specified by applying a voltage to the SD pin. The SD pin is *active high* and needs to be tied to V^- for normal operation. This input is low current (< 20- μ A, 4-pF equivalent capacitance) and a resistor to V^- (\leq 20 k Ω) results in normal operation. Shutdown is specified when SD pin is 0.4 V or less from V^+ at any operating supply voltage and temperature.

In the shutdown mode, essentially all internal device biasing is turned off in order to minimize supply current flow, and the output goes into Hi-Z (high impedance) mode. Complete device turnon and turnoff times vary considerably relative to the output loading conditions, output voltage, and input impedance, but is generally limited to less than 1 μ s (see [Electrical Characteristics: 2.7 V](#), [Electrical Characteristics: 5 V](#), and [Electrical Characteristics: \$\pm\$ 5 V](#))

During shutdown, the input stage has an equivalent circuit as shown in [Figure 20](#).

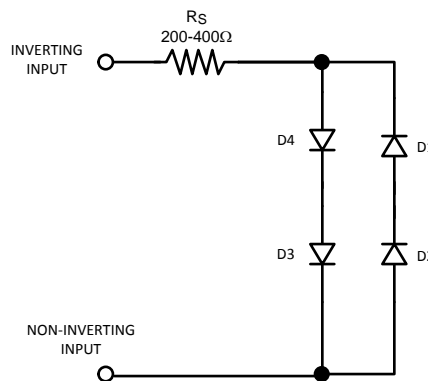

Figure 20. Input Stage Shutdown Equivalent Circuit

As can be seen from [Figure 20](#), in shutdown there may be current flow through the internal diodes shown, caused by input potential, if present. This current may flow through the external feedback resistor and result in an apparent output signal. In most shutdown applications the presence of this output is inconsequential. However, if the output is *forced* by another device such as in a multiplexer, the other device must conduct the current described in order to maintain the output potential.

To keep the output at or near ground during shutdown when there is no other device to hold the output low, a switch (transistor) could be used to shunt the output to ground. [Figure 21](#) shows a circuit where a NPN bipolar is used to keep the output near ground (approximately 80 mV):

Device Functional Modes (continued)

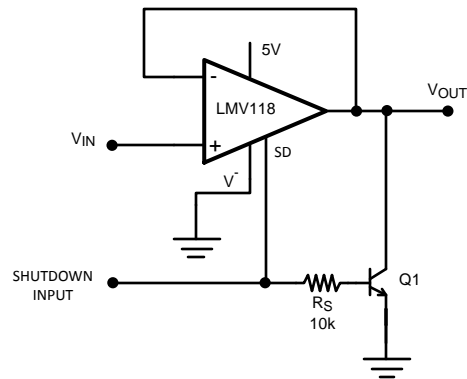

Figure 21. Active Pulldown Schematic

Figure 22 shows the output waveform.

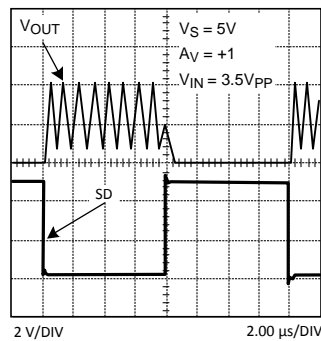

Figure 22. Output Held Low by Active Pulldown Circuit

If bipolar transistor power dissipation is not tolerable, the switch can be done by an N-channel enhancement-mode MOSFET.

8 Application and Implementation

NOTE

Information in the following applications sections is not part of the TI component specification, and TI does not warrant its accuracy or completeness. TI's customers are responsible for determining suitability of components for their purposes. Customers should validate and test their design implementation to confirm system functionality.

8.1 Application Information

The LMV11x rail-to-rail output voltage feedback amplifiers offer high-speed (45 MHz) operation with low input voltage (2.7 V). Output voltage range extends to within 20 mV of either supply rail, allowing wide dynamic range especially in low voltage applications. Even with low supply current of 600 μ A, output current capability is kept at a respectable ± 20 mA. For portable applications, the LMV118 provides shutdown capability while keeping the turnoff current to 15 μ A. Both turnon and turnoff characteristics are well behaved with minimal output fluctuations during transitions which enables the use of LMV118 in multiplexing applications.

8.2 Typical Application: 2.7-V Single Supply 2:1 MUX

The schematic shown in [Figure 23](#) functions as a 2:1 MUX operating on a single 2.7-V power supply, by utilizing the shutdown feature of the LMV118. Select input signal is connected to the shutdown pin of the first LMV118 through 74HC04 inverter. This signal is connected to the shutdown pin of the second LMV118 through another inverter. With this setup one of the LMV118 operational amplifiers is always in shutdown mode while the other is in active mode.

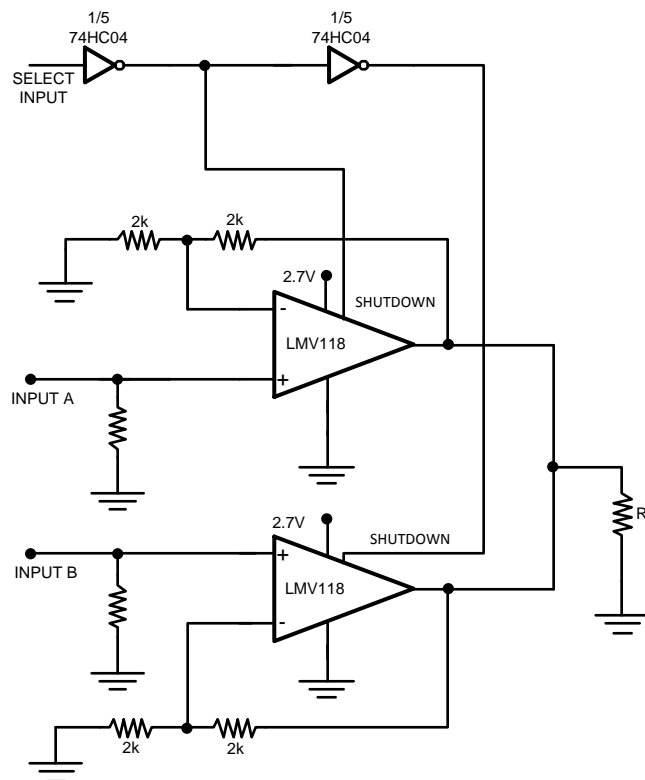

Figure 23. 2:1 MUX Operating Off a 2.7-V Single Supply

Typical Application: 2.7-V Single Supply 2:1 MUX (continued)

8.2.1 Design Requirements

For typical operational-amplifier applications, use the parameters listed in [Table 1](#).

Table 1. Design Parameters

DESIGN PARAMETER	EXAMPLE VALUE
Supply voltage	2.7 V
Linear output current	±20 mA (typical)
PSRR	85 dB (typical)

8.2.2 Detailed Design Procedure

It is important to carefully select the values of the external resistors. Choosing large valued external resistors affects the closed-loop behavior of the stage because of the interaction of these resistors with parasitic capacitances. These capacitors could be inherent to the device or a by-product of the board layout and component placement. Either way, keeping the resistor values lower diminishes this interaction. On the other hand, choosing very low-value resistors could load down nodes and contribute to higher overall power dissipation.

8.2.3 Application Curve

[Figure 24](#) shows the MUX output when selecting between a 1-MHz sine and a 250-kHz triangular waveform.

As can be seen in [Figure 24](#), the output is well behaved, and there are no spikes or glitches due to the switching. Switching times are approximately around 500 ns based on the time when the output is considered *valid*.

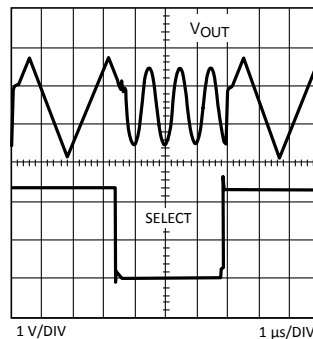

Figure 24. 2:1 MUX Output

9 Power Supply Recommendations

The LMV11x is specified for operation from 2.7 V to 12 V (± 1.35 V to ± 6 V) over a -40°C to $+85^{\circ}\text{C}$ temperature range. For proper operation, the power supplies must be properly decoupled. For decoupling the supply lines it is suggested that 100-nF capacitors be placed as close as possible to the operational amplifier power supply pins. For single supply, place a capacitor between V+ and V– supply leads. For dual supplies, place one capacitor between V+ and ground, and one capacitor between V– and ground.

10 Layout

10.1 Layout Guidelines

Generally, a good high-frequency layout keeps power supply and ground traces away from the inverting input and output pins. Parasitic capacitances on these nodes to ground cause frequency response peaking and possible circuit oscillations (see [OA-15 Frequent Faux Pas in Applying Wideband Current Feedback Amplifiers](#) for more information).

TI suggests the following evaluation boards as a guide for high-frequency layout and as an aid in device testing and characterization:

DEVICE	PACKAGE	EVALUATION BOARD P/N
LMV116	SOT-23-5	CLC730068
LMV118	SOT-23-6	CLC730116

10.2 Layout Example

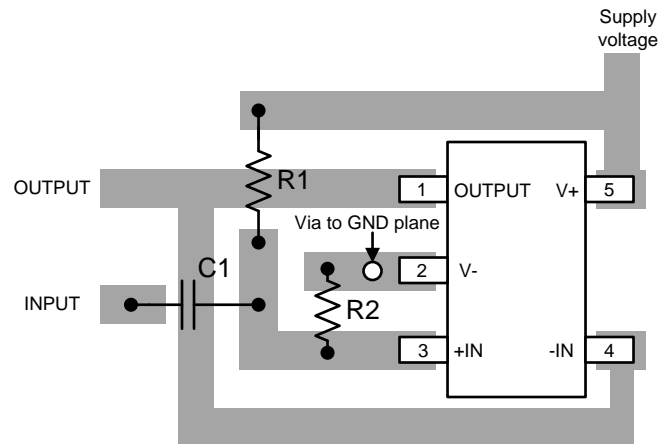

Figure 25. LMV116/LMV118 Layout

11 Device and Documentation Support

11.1 Related Documentation

For additional information, see the following:

[OA-15 Frequent Faux Pas in Applying Wideband Current Feedback Amplifiers](#)

11.2 Related Links

[Table 2](#) lists quick access links. Categories include technical documents, support and community resources, tools and software, and quick access to sample or buy.

Table 2. Related Links

PARTS	PRODUCT FOLDER	SAMPLE & BUY	TECHNICAL DOCUMENTS	TOOLS & SOFTWARE	SUPPORT & COMMUNITY
LMV116	Click here	Click here	Click here	Click here	Click here
LMV118	Click here	Click here	Click here	Click here	Click here

11.3 Receiving Notification of Documentation Updates

To receive notification of documentation updates, navigate to the device product folder on ti.com. In the upper right corner, click on *Alert me* to register and receive a weekly digest of any product information that has changed. For change details, review the revision history included in any revised document.

11.4 Community Resources

The following links connect to TI community resources. Linked contents are provided "AS IS" by the respective contributors. They do not constitute TI specifications and do not necessarily reflect TI's views; see TI's [Terms of Use](#).

TI E2E™ Online Community *TI's Engineer-to-Engineer (E2E) Community*. Created to foster collaboration among engineers. At e2e.ti.com, you can ask questions, share knowledge, explore ideas and help solve problems with fellow engineers.

Design Support *TI's Design Support* Quickly find helpful E2E forums along with design support tools and contact information for technical support.

11.5 Trademarks

E2E is a trademark of Texas Instruments.
All other trademarks are the property of their respective owners.

11.6 Electrostatic Discharge Caution



These devices have limited built-in ESD protection. The leads should be shorted together or the device placed in conductive foam during storage or handling to prevent electrostatic damage to the MOS gates.

11.7 Glossary

[SLYZ022](#) — *TI Glossary*.

This glossary lists and explains terms, acronyms, and definitions.

12 Mechanical, Packaging, and Orderable Information

The following pages include mechanical, packaging, and orderable information. This information is the most current data available for the designated devices. This data is subject to change without notice and revision of this document. For browser-based versions of this data sheet, refer to the left-hand navigation.

PACKAGING INFORMATION

Orderable Device	Status (1)	Package Type	Package Drawing	Pins	Package Qty	Eco Plan (2)	Lead/Ball Finish (6)	MSL Peak Temp (3)	Op Temp (°C)	Device Marking (4/5)	Samples
LMV116MF/NOPB	ACTIVE	SOT-23	DBV	5	1000	Green (RoHS & no Sb/Br)	CU SN	Level-1-260C-UNLIM	-40 to 85	AC1A	Samples
LMV116MFX/NOPB	ACTIVE	SOT-23	DBV	5	3000	Green (RoHS & no Sb/Br)	CU SN	Level-1-260C-UNLIM	-40 to 85	AC1A	Samples
LMV118MF/NOPB	ACTIVE	SOT-23	DBV	6	1000	Green (RoHS & no Sb/Br)	CU SN	Level-1-260C-UNLIM	-40 to 85	AD1A	Samples
LMV118MFX/NOPB	ACTIVE	SOT-23	DBV	6	3000	Green (RoHS & no Sb/Br)	CU SN	Level-1-260C-UNLIM	-40 to 85	AD1A	Samples

(1) The marketing status values are defined as follows:

ACTIVE: Product device recommended for new designs.

LIFEBUY: TI has announced that the device will be discontinued, and a lifetime-buy period is in effect.

NRND: Not recommended for new designs. Device is in production to support existing customers, but TI does not recommend using this part in a new design.

PREVIEW: Device has been announced but is not in production. Samples may or may not be available.

OBSOLETE: TI has discontinued the production of the device.

(2) Eco Plan - The planned eco-friendly classification: Pb-Free (RoHS), Pb-Free (RoHS Exempt), or Green (RoHS & no Sb/Br) - please check <http://www.ti.com/productcontent> for the latest availability information and additional product content details.

TBD: The Pb-Free/Green conversion plan has not been defined.

Pb-Free (RoHS): TI's terms "Lead-Free" or "Pb-Free" mean semiconductor products that are compatible with the current RoHS requirements for all 6 substances, including the requirement that lead not exceed 0.1% by weight in homogeneous materials. Where designed to be soldered at high temperatures, TI Pb-Free products are suitable for use in specified lead-free processes.

Pb-Free (RoHS Exempt): This component has a RoHS exemption for either 1) lead-based flip-chip solder bumps used between the die and package, or 2) lead-based die adhesive used between the die and leadframe. The component is otherwise considered Pb-Free (RoHS compatible) as defined above.

Green (RoHS & no Sb/Br): TI defines "Green" to mean Pb-Free (RoHS compatible), and free of Bromine (Br) and Antimony (Sb) based flame retardants (Br or Sb do not exceed 0.1% by weight in homogeneous material)

(3) MSL, Peak Temp. - The Moisture Sensitivity Level rating according to the JEDEC industry standard classifications, and peak solder temperature.

(4) There may be additional marking, which relates to the logo, the lot trace code information, or the environmental category on the device.

(5) Multiple Device Markings will be inside parentheses. Only one Device Marking contained in parentheses and separated by a "~" will appear on a device. If a line is indented then it is a continuation of the previous line and the two combined represent the entire Device Marking for that device.

(6) Lead/Ball Finish - Orderable Devices may have multiple material finish options. Finish options are separated by a vertical ruled line. Lead/Ball Finish values may wrap to two lines if the finish value exceeds the maximum column width.

Important Information and Disclaimer: The information provided on this page represents TI's knowledge and belief as of the date that it is provided. TI bases its knowledge and belief on information provided by third parties, and makes no representation or warranty as to the accuracy of such information. Efforts are underway to better integrate information from third parties. TI has taken and continues to take reasonable steps to provide representative and accurate information but may not have conducted destructive testing or chemical analysis on incoming materials and chemicals. TI and TI suppliers consider certain information to be proprietary, and thus CAS numbers and other limited information may not be available for release.

In no event shall TI's liability arising out of such information exceed the total purchase price of the TI part(s) at issue in this document sold by TI to Customer on an annual basis.

TAPE AND REEL INFORMATION

QUADRANT ASSIGNMENTS FOR PIN 1 ORIENTATION IN TAPE

*All dimensions are nominal

Device	Package Type	Package Drawing	Pins	SPQ	Reel Diameter (mm)	Reel Width W1 (mm)	A0 (mm)	B0 (mm)	K0 (mm)	P1 (mm)	W (mm)	Pin1 Quadrant
LMV116MF/NOPB	SOT-23	DBV	5	1000	178.0	8.4	3.2	3.2	1.4	4.0	8.0	Q3
LMV116MFX/NOPB	SOT-23	DBV	5	3000	178.0	8.4	3.2	3.2	1.4	4.0	8.0	Q3
LMV118MF/NOPB	SOT-23	DBV	6	1000	178.0	8.4	3.2	3.2	1.4	4.0	8.0	Q3
LMV118MFX/NOPB	SOT-23	DBV	6	3000	178.0	8.4	3.2	3.2	1.4	4.0	8.0	Q3

TAPE AND REEL BOX DIMENSIONS

*All dimensions are nominal

Device	Package Type	Package Drawing	Pins	SPQ	Length (mm)	Width (mm)	Height (mm)
LMV116MF/NOPB	SOT-23	DBV	5	1000	210.0	185.0	35.0
LMV116MFX/NOPB	SOT-23	DBV	5	3000	210.0	185.0	35.0
LMV118MF/NOPB	SOT-23	DBV	6	1000	210.0	185.0	35.0
LMV118MFX/NOPB	SOT-23	DBV	6	3000	210.0	185.0	35.0

EXAMPLE BOARD LAYOUT

DBV0006A

SOT-23 - 1.45 mm max height

SMALL OUTLINE TRANSISTOR



LAND PATTERN EXAMPLE
EXPOSED METAL SHOWN
SCALE:15X



SOLDER MASK DETAILS

4214840/B 03/2018

NOTES: (continued)

- 6. Publication IPC-7351 may have alternate designs.
- 7. Solder mask tolerances between and around signal pads can vary based on board fabrication site.

EXAMPLE STENCIL DESIGN

DBV0006A

SOT-23 - 1.45 mm max height

SMALL OUTLINE TRANSISTOR



SOLDER PASTE EXAMPLE
BASED ON 0.125 mm THICK STENCIL
SCALE:15X

4214840/B 03/2018

NOTES: (continued)

8. Laser cutting apertures with trapezoidal walls and rounded corners may offer better paste release. IPC-7525 may have alternate design recommendations.
9. Board assembly site may have different recommendations for stencil design.

EXAMPLE BOARD LAYOUT

DBV0005A

SOT-23 - 1.45 mm max height

SMALL OUTLINE TRANSISTOR



LAND PATTERN EXAMPLE
EXPOSED METAL SHOWN
SCALE:15X



SOLDER MASK DETAILS

4214839/D 11/2018

NOTES: (continued)

- 5. Publication IPC-7351 may have alternate designs.
- 6. Solder mask tolerances between and around signal pads can vary based on board fabrication site.

EXAMPLE STENCIL DESIGN

DBV0005A

SOT-23 - 1.45 mm max height

SMALL OUTLINE TRANSISTOR



SOLDER PASTE EXAMPLE
BASED ON 0.125 mm THICK STENCIL
SCALE:15X

4214839/D 11/2018

NOTES: (continued)

7. Laser cutting apertures with trapezoidal walls and rounded corners may offer better paste release. IPC-7525 may have alternate design recommendations.
8. Board assembly site may have different recommendations for stencil design.

IMPORTANT NOTICE AND DISCLAIMER

TI PROVIDES TECHNICAL AND RELIABILITY DATA (INCLUDING DATASHEETS), DESIGN RESOURCES (INCLUDING REFERENCE DESIGNS), APPLICATION OR OTHER DESIGN ADVICE, WEB TOOLS, SAFETY INFORMATION, AND OTHER RESOURCES "AS IS" AND WITH ALL FAULTS, AND DISCLAIMS ALL WARRANTIES, EXPRESS AND IMPLIED, INCLUDING WITHOUT LIMITATION ANY IMPLIED WARRANTIES OF MERCHANTABILITY, FITNESS FOR A PARTICULAR PURPOSE OR NON-INFRINGEMENT OF THIRD PARTY INTELLECTUAL PROPERTY RIGHTS.

These resources are intended for skilled developers designing with TI products. You are solely responsible for (1) selecting the appropriate TI products for your application, (2) designing, validating and testing your application, and (3) ensuring your application meets applicable standards, and any other safety, security, or other requirements. These resources are subject to change without notice. TI grants you permission to use these resources only for development of an application that uses the TI products described in the resource. Other reproduction and display of these resources is prohibited. No license is granted to any other TI intellectual property right or to any third party intellectual property right. TI disclaims responsibility for, and you will fully indemnify TI and its representatives against, any claims, damages, costs, losses, and liabilities arising out of your use of these resources.

TI's products are provided subject to TI's Terms of Sale (www.ti.com/legal/termsofsale.html) or other applicable terms available either on ti.com or provided in conjunction with such TI products. TI's provision of these resources does not expand or otherwise alter TI's applicable warranties or warranty disclaimers for TI products.

Mailing Address: Texas Instruments, Post Office Box 655303, Dallas, Texas 75265
Copyright © 2019, Texas Instruments Incorporated

Looking for pricing, stock, or lifecycle information?

Click below to explore more details on WIN SOURCE:

 [View LMV116MF/NOPB on WIN SOURCE](#)

 [Texas Instruments](#) Information

Optimize Your Supply Chain with WIN SOURCE Solutions

-  Global Sourcing Solution
-  Obsolete Management
-  Cost Control Management
-  Shortage Management
-  Alternative Solution
-  Excess Inventory Management