



THE DATASHEET OF INA226AIDGSR



Table of Contents

1 Features	1	7.5 Programming	15
2 Applications	1	7.6 Register Maps	21
3 Description	1	8 Application and Implementation	28
4 Revision History	2	8.1 Application Information	28
5 Pin Configuration and Functions	3	8.2 Typical Applications	28
6 Specifications	4	9 Power Supply Recommendations	30
6.1 Absolute Maximum Ratings	4	10 Layout	30
6.2 ESD Ratings	4	10.1 Layout Guidelines	30
6.3 Recommended Operating Conditions	4	10.2 Layout Example	30
6.4 Thermal Information	4	11 Device and Documentation Support	31
6.5 Electrical Characteristics	5	11.1 Device Support	31
6.6 Typical Characteristics	7	11.2 Community Resources	31
7 Detailed Description	10	11.3 Trademarks	31
7.1 Overview	10	11.4 Electrostatic Discharge Caution	31
7.2 Functional Block Diagram	10	11.5 Glossary	31
7.3 Feature Description	10	12 Mechanical, Packaging, and Orderable Information	31
7.4 Device Functional Modes	13		

4 Revision History

Changes from Original (June 2011) to Revision A

Page

- Added *Handling Rating* table, *Feature Description* section, *Device Functional Modes*, *Application and Implementation* section, *Power Supply Recommendations* section, *Layout* section, *Device and Documentation Support* section, and *Mechanical, Packaging, and Orderable Information* section **1**

5 Pin Configuration and Functions

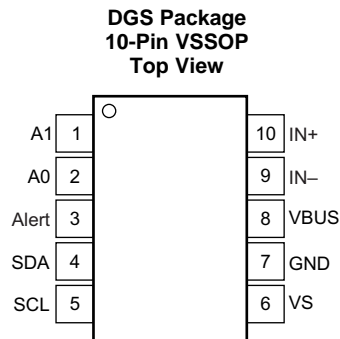

Pin Functions

PIN		I/O	DESCRIPTION
NAME	NO.		
A0	2	Digital input	Address pin. Connect to GND, SCL, SDA, or VS. Table 2 shows pin settings and corresponding addresses.
A1	1	Digital input	Address pin. Connect to GND, SCL, SDA, or VS. Table 2 shows pin settings and corresponding addresses.
Alert	3	Digital output	Multi-functional alert, open-drain output.
GND	7	Analog	Ground.
IN+	10	Analog input	Connect to supply side of shunt resistor.
IN-	9	Analog input	Connect to load side of shunt resistor.
SCL	5	Digital input	Serial bus clock line, open-drain input.
SDA	4	Digital I/O	Serial bus data line, open-drain input/output.
VBUS	8	Analog input	Bus voltage input.
VS	6	Analog	Power supply, 2.7 V to 5.5 V.

6 Specifications

6.1 Absolute Maximum Ratings

 over operating free-air temperature range (unless otherwise noted) ⁽¹⁾

		MIN	MAX	UNIT
V _{VS}	Supply voltage		6	V
Analog Inputs, IN+, IN–	Differential (V _{IN+} – V _{IN–}) ⁽²⁾	–40	40	V
	Common-Mode (V _{IN+} + V _{IN–}) / 2	–0.3	40	
V _{VBUS}		–0.3	40	V
V _{SDA}		GND – 0.3	6	V
V _{SCL}		GND – 0.3	V _{VS} + 0.3	V
I _{IN}	Input current into any pin		5	mA
I _{OUT}	Open-drain digital output current		10	mA
T _J	Junction temperature		150	°C
T _{stg}	Storage temperature range	–65	150	°C

- (1) Stresses beyond those listed under *Absolute Maximum Ratings* may cause permanent damage to the device. These are stress ratings only, which do not imply functional operation of the device at these or any other conditions beyond those indicated under *Recommended Operating Conditions*. Exposure to absolute-maximum-rated conditions for extended periods may affect device reliability.
- (2) IN+ and IN– may have a differential voltage between –40 V and 40 V. However, the voltage at these pins must not exceed the range –0.3 V to 40 V.

6.2 ESD Ratings

		VALUE	UNIT
V _(ESD)	Electrostatic discharge	Human body model (HBM), per ANSI/ESDA/JEDEC JS-001, all pins ⁽¹⁾	V
		Charged device model (CDM), per JEDEC specification JESD22-C101, all pins ⁽²⁾	
		Machine model (MM)	

- (1) JEDEC document JEP155 states that 500-V HBM allows safe manufacturing with a standard ESD control process.
- (2) JEDEC document JEP157 states that 250-V CDM allows safe manufacturing with a standard ESD control process.

6.3 Recommended Operating Conditions

over operating free-air temperature range (unless otherwise noted)

		MIN	NOM	MAX	UNIT
V _{CM}	Common-mode input voltage		12		V
V _{VS}	Operating supply voltage		3.3		V
T _A	Operating free-air temperature	–40		125	°C

6.4 Thermal Information

THERMAL METRIC ⁽¹⁾		INA226	UNIT
		DGS (VSSOP)	
		10 PINS	
R _{θJA}	Junction-to-ambient thermal resistance	171.4	°C/W
R _{θJC(top)}	Junction-to-case (top) thermal resistance	42.9	°C/W
R _{θJB}	Junction-to-board thermal resistance	91.8	°C/W
Ψ _{JT}	Junction-to-top characterization parameter	1.5	°C/W
Ψ _{JB}	Junction-to-board characterization parameter	90.2	°C/W
R _{θJC(bot)}	Junction-to-case (bottom) thermal resistance	n/a	°C/W

- (1) For more information about traditional and new thermal metrics, see the *Semiconductor and IC Package Thermal Metrics* application report, [SPRA953](#).

6.5 Electrical Characteristics

 $T_A = 25^\circ\text{C}$, $V_{VS} = 3.3\text{ V}$, $V_{IN+} = 12\text{ V}$, $V_{SENSE} = (V_{IN+} - V_{IN-}) = 0\text{ mV}$ and $V_{VBUS} = 12\text{ V}$, unless otherwise noted

PARAMETER	TEST CONDITIONS	MIN	TYP	MAX	UNIT	
INPUT						
	Shunt voltage input range	-81.9175		81.92	mV	
	Bus voltage input range ⁽¹⁾	0		36	V	
CMRR	Common-mode rejection	$0\text{ V} \leq V_{IN+} \leq 36\text{ V}$	126	140	dB	
V_{OS}	Shunt offset voltage, RTI ⁽²⁾		± 2.5	± 10	μV	
	Shunt offset voltage, RTI ⁽²⁾ vs temperature	$-40^\circ\text{C} \leq T_A \leq 125^\circ\text{C}$	0.02	0.1	$\mu\text{V}/^\circ\text{C}$	
PSRR	Shunt offset voltage, RTI ⁽²⁾ vs Power supply	$2.7\text{ V} \leq VS \leq 5.5\text{ V}$	2.5		$\mu\text{V}/\text{V}$	
V_{OS}	Bus offset voltage, RTI ⁽²⁾		± 1.25	± 7.5	mV	
	Bus offset voltage, RTI ⁽²⁾ vs temperature	$-40^\circ\text{C} \leq T_A \leq 125^\circ\text{C}$	10	40	$\mu\text{V}/^\circ\text{C}$	
PSRR	Bus offset voltage, RTI ⁽²⁾ vs power supply		0.5		mV/V	
I_B	Input bias current (I_{IN+} , I_{IN-} pins)		10		μA	
	VBUS input impedance		830		k Ω	
	Input leakage ⁽³⁾	(IN+ pin) + (IN- pin), Power-down mode	0.1	0.5	μA	
DC ACCURACY						
	ADC native resolution		16		Bits	
1 LSB step size	Shunt voltage		2.5		μV	
	Bus voltage		1.25		mV	
	Shunt voltage gain error		0.02%	0.1%		
	Shunt voltage gain error vs temperature	$-40^\circ\text{C} \leq T_A \leq 125^\circ\text{C}$	10	50	ppm/ $^\circ\text{C}$	
	Bus voltage gain error		0.02%	0.1%		
	Bus voltage gain error vs temperature	$-40^\circ\text{C} \leq T_A \leq 125^\circ\text{C}$	10	50	ppm/ $^\circ\text{C}$	
	Differential nonlinearity		± 0.1		LSB	
t_{CT}	ADC conversion time	CT bit = 000		140	154	μs
		CT bit = 001		204	224	
		CT bit = 010		332	365	
		CT bit = 011		588	646	
		CT bit = 100		1.1	1.21	ms
		CT bit = 101		2.116	2.328	
		CT bit = 110		4.156	4.572	
		CT bit = 111		8.244	9.068	
SMBus						
	SMBus timeout ⁽⁴⁾		28	35	ms	

(1) While the input range is 36 V, the full-scale range of the ADC scaling is 40.96 V. See the [Basic ADC Functions](#) section. Do not apply more than 36 V.

(2) RTI = Referred-to-input.

(3) Input leakage is positive (current flowing into the pin) for the conditions shown at the top of this table. Negative leakage currents can occur under different input conditions.

(4) SMBus timeout in the INA226 resets the interface any time SCL is low for more than 28 ms.

Electrical Characteristics (continued)
 $T_A = 25^\circ\text{C}$, $V_{VS} = 3.3\text{ V}$, $V_{IN+} = 12\text{ V}$, $V_{SENSE} = (V_{IN+} - V_{IN-}) = 0\text{ mV}$ and $V_{VBUS} = 12\text{ V}$, unless otherwise noted

PARAMETER	TEST CONDITIONS	MIN	TYP	MAX	UNIT
DIGITAL INPUT/OUTPUT					
Input capacitance			3		pF
Leakage input current	$0\text{ V} \leq V_{SCL} \leq V_{VS}$, $0\text{ V} \leq V_{SDA} \leq V_{VS}$, $0\text{ V} \leq V_{Alert} \leq V_{VS}$, $0\text{ V} \leq V_{A0} \leq V_{VS}$, $0\text{ V} \leq V_{A1} \leq V_{VS}$		0.1	1	μA
V_{IH}	High-level input voltage		$0.7 \times V_{VS}$	6	V
V_{IL}	Low-level input voltage		-0.5	$0.3 \times V_{VS}$	V
V_{OL}	Low-level output voltage, SDA, Alert	$I_{OL} = 3\text{ mA}$	0	0.4	V
	Hysteresis		500		mV
POWER SUPPLY					
	Operating supply range		2.7	5.5	V
I_Q	Quiescent current		330	420	μA
	Quiescent current, power-down (shutdown) mode		0.5	2	μA
V_{POR}	Power-on reset threshold		2		V

6.6 Typical Characteristics

At $T_A = 25^\circ\text{C}$, $V_{VS} = 3.3\text{ V}$, $V_{IN+} = 12\text{ V}$, $V_{SENSE} = (V_{IN+} - V_{IN-}) = 0\text{ mV}$ and $V_{VBUS} = 12\text{ V}$, unless otherwise noted.

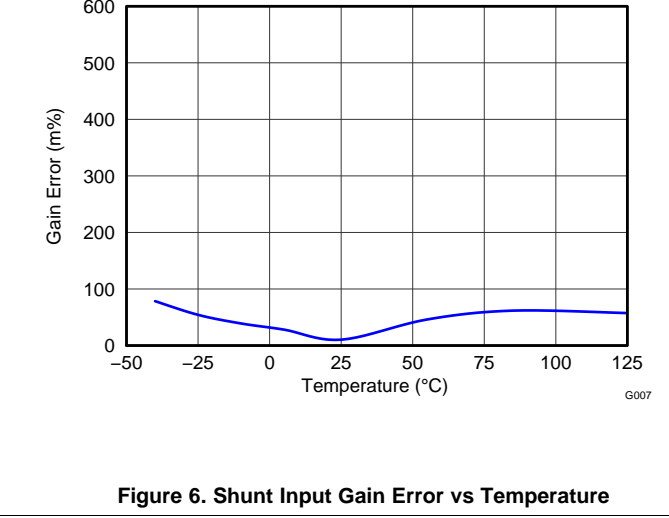
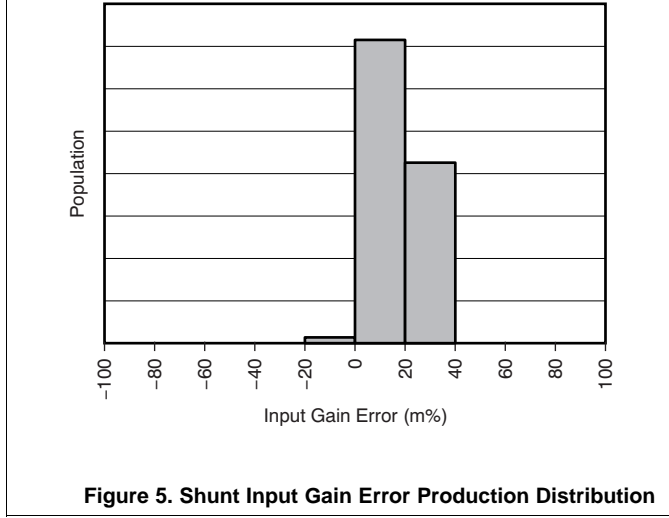
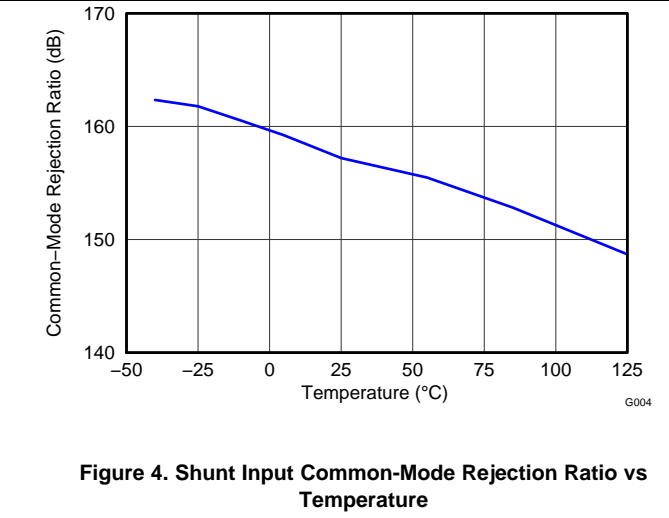
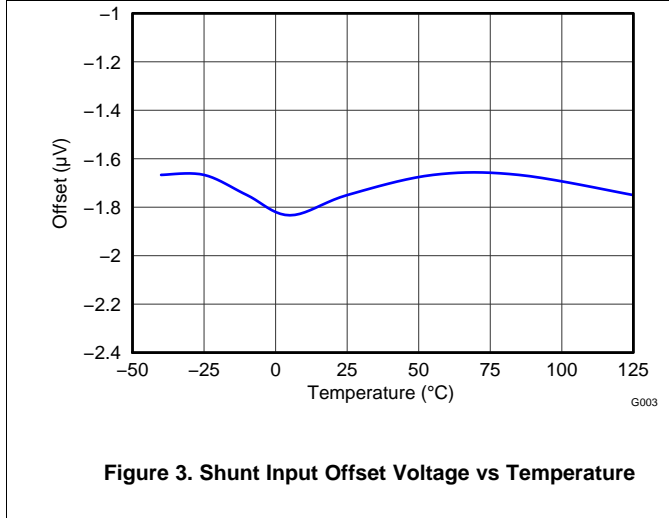
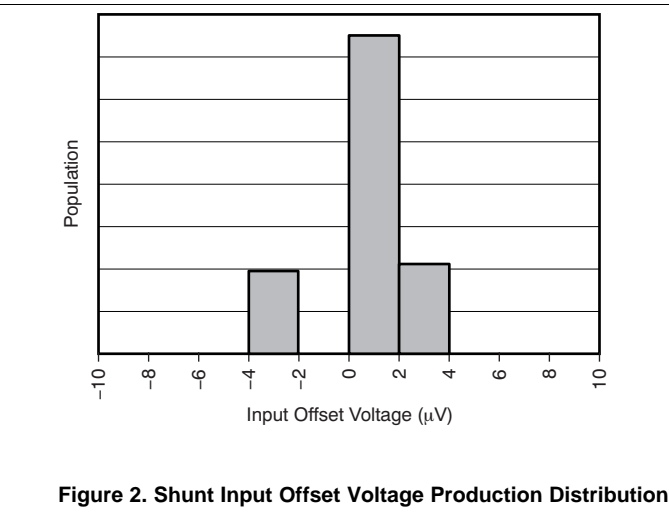
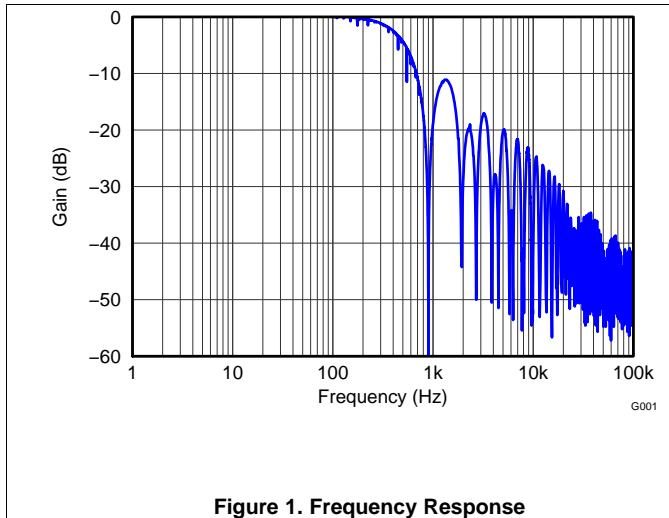

Typical Characteristics (continued)

At $T_A = 25^\circ\text{C}$, $V_{VS} = 3.3\text{ V}$, $V_{IN+} = 12\text{ V}$, $V_{SENSE} = (V_{IN+} - V_{IN-}) = 0\text{ mV}$ and $V_{VBUS} = 12\text{ V}$, unless otherwise noted.

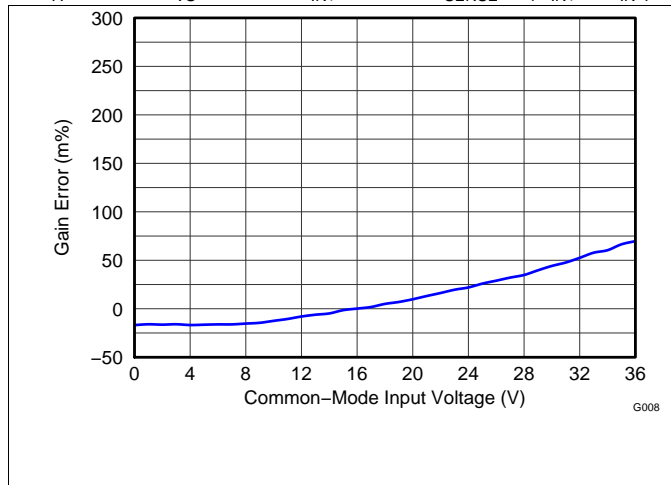

Figure 7. Shunt Input Gain Error vs Common-Mode Voltage

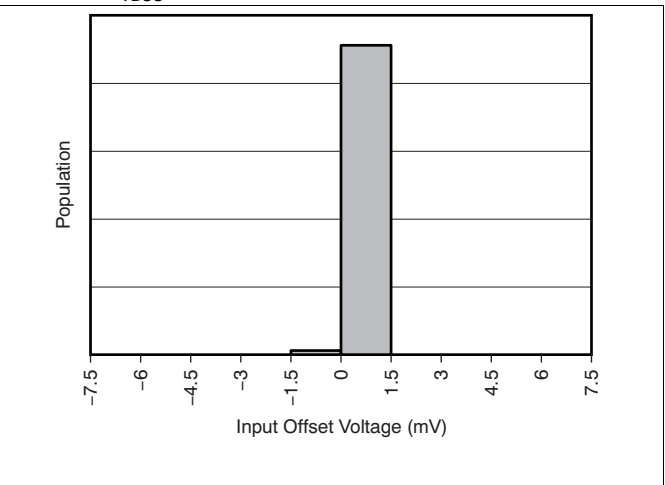

Figure 8. Bus Input Offset Voltage Production Distribution

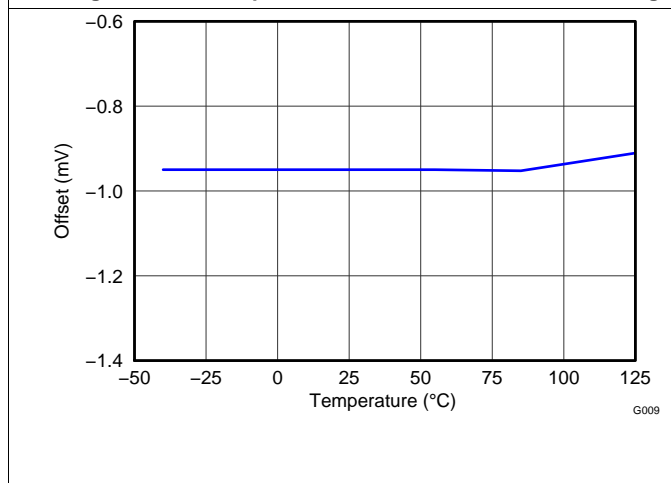

Figure 9. Bus Input Offset Voltage vs Temperature

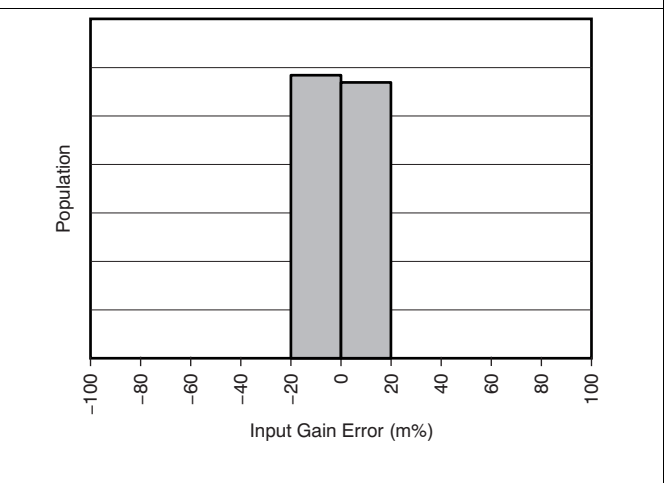

Figure 10. Bus Input Gain Error Production Distribution

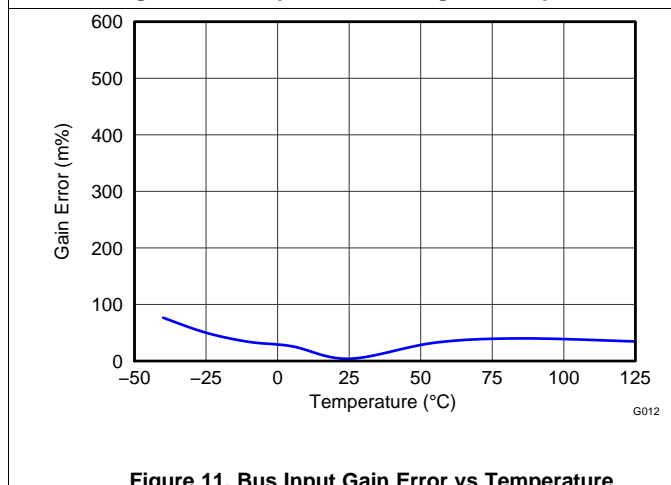

Figure 11. Bus Input Gain Error vs Temperature

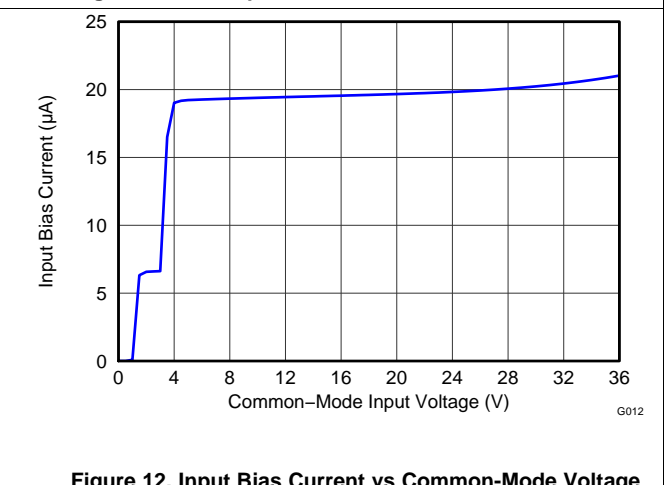

Figure 12. Input Bias Current vs Common-Mode Voltage

Typical Characteristics (continued)

At $T_A = 25^\circ\text{C}$, $V_{VS} = 3.3\text{ V}$, $V_{IN+} = 12\text{ V}$, $V_{SENSE} = (V_{IN+} - V_{IN-}) = 0\text{ mV}$ and $V_{VBUS} = 12\text{ V}$, unless otherwise noted.

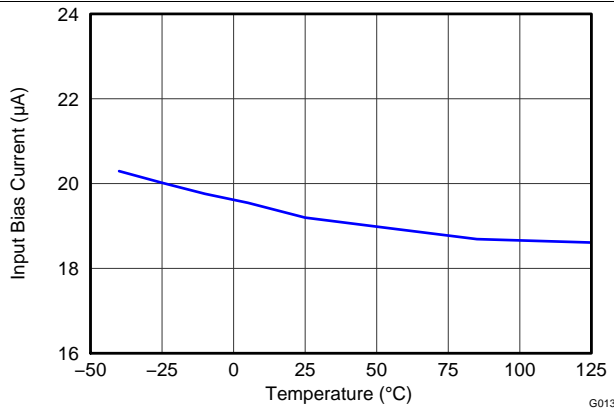

Figure 13. Input Bias Current vs Temperature

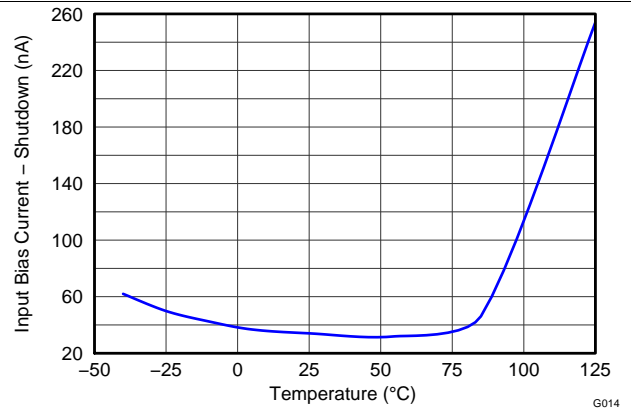

Figure 14. Input Bias Current vs Temperature, Shutdown

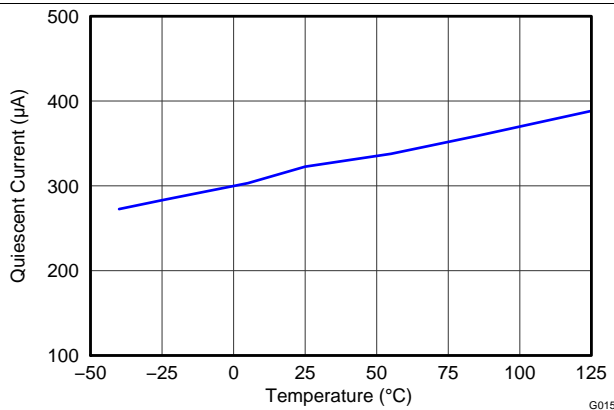

Figure 15. Active I_Q vs Temperature

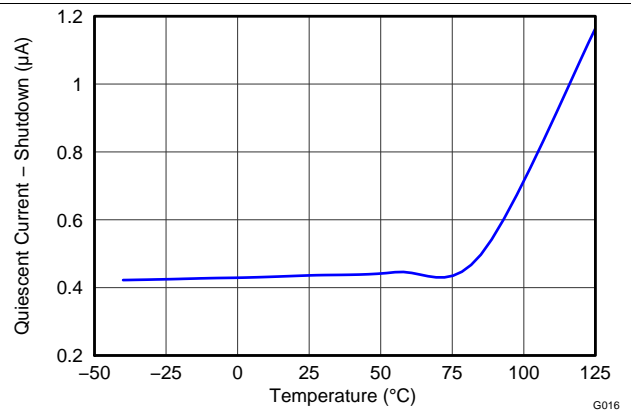

Figure 16. Shutdown I_Q vs Temperature

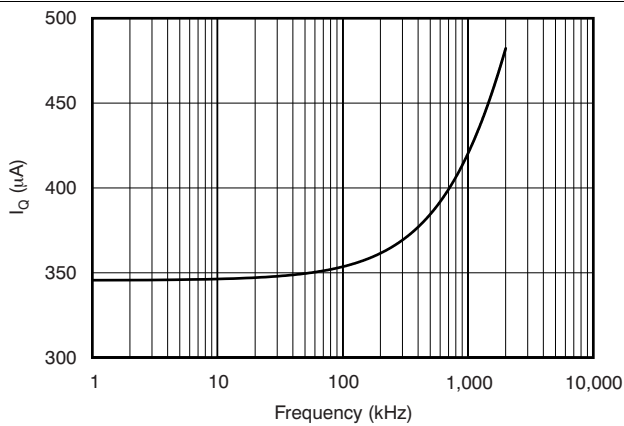

Figure 17. Active I_Q vs I^2C Clock Frequency

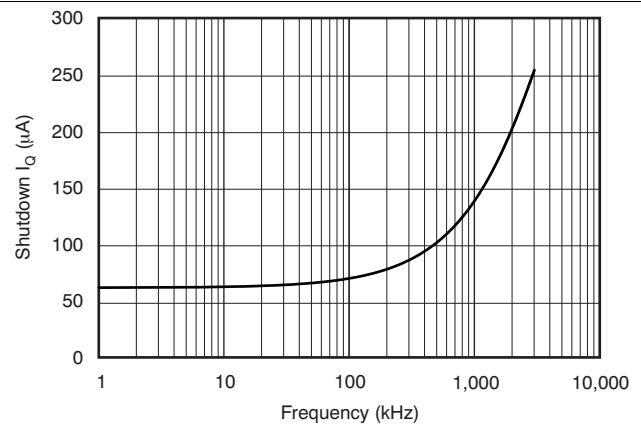

Figure 18. Shutdown I_Q vs I^2C Clock Frequency

7 Detailed Description

7.1 Overview

The INA226 is a digital current sense amplifier with an I²C- and SMBus-compatible interface. It provides digital current, voltage, and power readings necessary for accurate decision-making in precisely-controlled systems. Programmable registers allow flexible configuration for measurement resolution as well as continuous-versus-triggered operation. Detailed register information appears at the end of this data sheet, beginning with [Table 4](#). See the [Functional Block Diagram](#) section for a block diagram of the INA226 device.

7.2 Functional Block Diagram

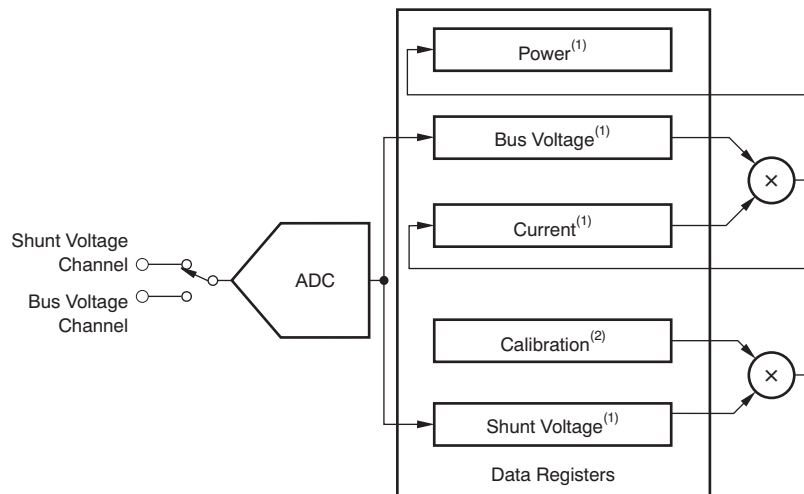

(1) Read-only

(2) Read/write

7.3 Feature Description

7.3.1 Basic ADC Functions

The INA226 device performs two measurements on the power-supply bus of interest. The voltage developed from the load current that flows through a shunt resistor creates a shunt voltage that is measured at the IN+ and IN– pins. The device can also measure the power supply bus voltage by connecting this voltage to the VBUS pin. The differential shunt voltage is measured with respect to the IN– pin while the bus voltage is measured with respect to ground.

The device is typically powered by a separate supply that can range from 2.7 V to 5.5 V. The bus that is being monitored can range in voltage from 0 V to 36 V. Based on the fixed 1.25-mV LSB for the Bus Voltage Register that a full-scale register results in a 40.96 V value.

NOTE

Do not apply more than 36 V of actual voltage to the input pins.

There are no special considerations for power-supply sequencing because the common-mode input range and power-supply voltage are independent of each other; therefore, the bus voltage can be present with the supply voltage off, and vice-versa.

The device takes two measurements, shunt voltage and bus voltage. It then converts these measurements to current, based on the Calibration Register value, and then calculates power. Refer to the [Programming the Calibration Register](#) section for additional information on programming the Calibration Register.

Feature Description (continued)

The device has two operating modes, continuous and triggered, that determine how the ADC operates following these conversions. When the device is in the normal operating mode (that is, MODE bits of the Configuration Register (00h) are set to '111'), it continuously converts a shunt voltage reading followed by a bus voltage reading. After the shunt voltage reading, the current value is calculated (based on [Equation 3](#)). This current value is then used to calculate the power result (using [Equation 4](#)). These values are subsequently stored in an accumulator, and the measurement/calculation sequence repeats until the number of averages set in the Configuration Register (00h) is reached. Following every sequence, the present set of values measured and calculated are appended to previously collected values. After all of the averaging has been completed, the final values for shunt voltage, bus voltage, current, and power are updated in the corresponding registers that can then be read. These values remain in the data output registers until they are replaced by the next fully completed conversion results. Reading the data output registers does not affect a conversion in progress.

The mode control in the Conversion Register (00h) also permits selecting modes to convert only the shunt voltage or the bus voltage in order to further allow the user to configure the monitoring function to fit the specific application requirements.

All current and power calculations are performed in the background and do not contribute to conversion time.

In triggered mode, writing any of the triggered convert modes into the Configuration Register (00h) (that is, MODE bits of the Configuration Register (00h) are set to '001', '010', or '011') triggers a single-shot conversion. This action produces a single set of measurements; thus, to trigger another single-shot conversion, the Configuration Register (00h) must be written to a second time, even if the mode does not change.

In addition to the two operating modes (continuous and triggered), the device also has a power-down mode that reduces the quiescent current and turns off current into the device inputs, reducing the impact of supply drain when the device is not being used. Full recovery from power-down mode requires 40µs. The registers of the device can be written to and read from while the device is in power-down mode. The device remains in power-down mode until one of the active modes settings are written into the Configuration Register (00h) .

Although the device can be read at any time, and the data from the last conversion remain available, the Conversion Ready flag bit (Mask/Enable Register, CVRF bit) is provided to help coordinate one-shot or triggered conversions. The Conversion Ready flag (CVRF) bit is set after all conversions, averaging, and multiplication operations are complete.

The Conversion Ready flag (CVRF) bit clears under these conditions:

- Writing to the Configuration Register (00h), except when configuring the MODE bits for power-down mode; or
- Reading the Mask/Enable Register (06h)

7.3.1.1 Power Calculation

The Current and Power are calculated following shunt voltage and bus voltage measurements as shown in [Figure 19](#). Current is calculated following a shunt voltage measurement based on the value set in the Calibration Register. If there is no value loaded into the Calibration Register, the current value stored is zero. Power is calculated following the bus voltage measurement based on the previous current calculation and bus voltage measurement. If there is no value loaded in the Calibration Register, the power value stored is also zero. Again, these calculations are performed in the background and do not add to the overall conversion time. These current and power values are considered intermediate results (unless the averaging is set to 1) and are stored in an internal accumulation register, not the corresponding output registers. Following every measured sample, the newly-calculated values for current and power are appended to this accumulation register until all of the samples have been measured and averaged based on the number of averages set in the Configuration Register (00h).

Feature Description (continued)

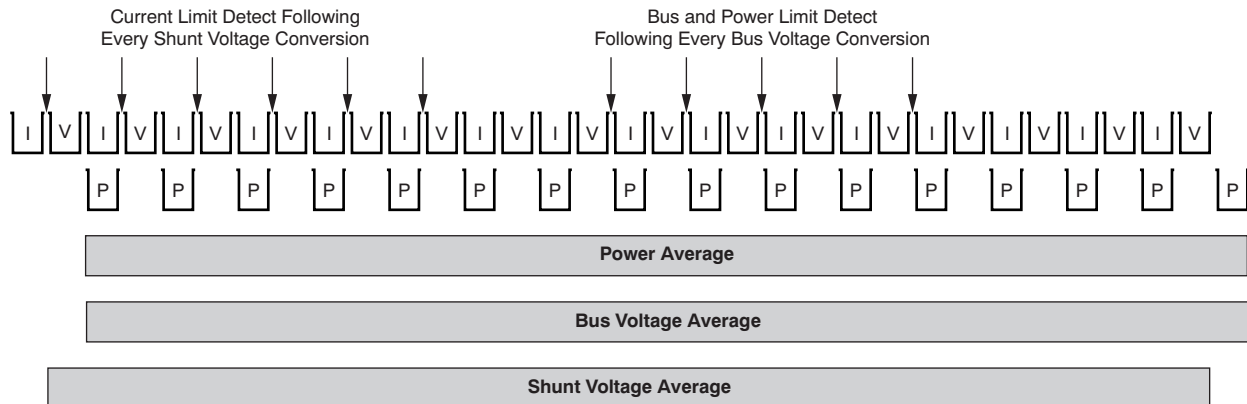

Figure 19. Power Calculation Scheme

In addition to the current and power accumulating after every sample, the shunt and bus voltage measurements are also collected. After all of the samples have been measured and the corresponding current and power calculations have been made, the accumulated average for each of these parameters is then loaded to the corresponding output registers, where they can then be read.

7.3.1.2 Alert Pin

The INA226 has a single Alert Limit Register (07h), that allows the Alert pin to be programmed to respond to a single user-defined event or to a Conversion Ready notification if desired. The Mask/Enable Register allows the user to select from one of the five available functions to monitor and/or set the Conversion Ready bit to control the response of the Alert pin. Based on the function being monitored, the user would then enter a value into the Alert Limit Register to set the corresponding threshold value that asserts the Alert pin.

The Alert pin allows for one of several available alert functions to be monitored to determine if a user-defined threshold has been exceeded. The five alert functions that can be monitored are:

- Shunt Voltage Over-Limit (SOL)
- Shunt Voltage Under-Limit (SUL)
- Bus Voltage Over-Limit (BOL)
- Bus Voltage Under-Limit (BUL)
- Power Over-Limit (POL)

The Alert pin is an open-drain output. This pin is asserted when the alert function selected in the Mask/Enable Register exceeds the value programmed into the Alert Limit Register. Only one of these alert functions can be enabled and monitored at a time. If multiple alert functions are enabled, the selected function in the highest significant bit position takes priority and responds to the Alert Limit Register value. For example, if the Shunt Voltage Over-Limit function and the Shunt Voltage Under-Limit function are both selected, the Alert pin asserts when the Shunt Voltage Register exceeds the value in the Alert Limit Register.

The Conversion Ready state of the device can also be monitored at the Alert pin to inform the user when the device has completed the previous conversion and is ready to begin a new conversion. Conversion Ready can be monitored at the Alert pin along with one of the alert functions. If an alert function and the Conversion Ready are both enabled to be monitored at the Alert pin, after the Alert pin is asserted, the Mask/Enable Register must be read following the alert to determine the source of the alert. By reading the Conversion Ready Flag (CVRF, bit 3), and the Alert Function Flag (AFF, bit 4) in the Mask/Enable Register, the source of the alert can be determined. If the Conversion Ready feature is not desired and the CNVR bit is not set, the Alert pin only responds to an exceeded alert limit based on the alert function enabled.

If the alert function is not used, the Alert pin can be left floating without impacting the operation of the device.

Feature Description (continued)

Refer to [Figure 19](#) to see the relative timing of when the value in the Alert Limit Register is compared to the corresponding converted value. For example, if the alert function that is enabled is Shunt Voltage Over-Limit (SOL), following every shunt voltage conversion the value in the Alert Limit Register is compared to the measured shunt voltage to determine if the measurements has exceeded the programmed limit. The AFF, bit 4 of the Mask/Enable Register, asserts high any time the measured voltage exceeds the value programmed into the Alert Limit Register. In addition to the AFF being asserted, the Alert pin is asserted based on the Alert Polarity Bit (APOL, bit 1 of the Mask/Enable Register). If the Alert Latch is enabled, the AFF and Alert pin remain asserted until either the Configuration Register (00h) is written to or the Mask/Enable Register is read.

The Bus Voltage alert functions compare the measured bus voltage to the Alert Limit Register following every bus voltage conversion and assert the AFF bit and Alert pin if the limit threshold is exceeded.

The Power Over-Limit alert function is also compared to the calculated power value following every bus voltage measurement conversion and asserts the AFF bit and Alert pin if the limit threshold is exceeded.

7.4 Device Functional Modes

7.4.1 Averaging and Conversion Time Considerations

The INA226 device offers programmable conversion times (t_{CT}) for both the shunt voltage and bus voltage measurements. The conversion times for these measurements can be selected from as fast as 140 μ s to as long as 8.244 ms. The conversion time settings, along with the programmable averaging mode, allow the device to be configured to optimize the available timing requirements in a given application. For example, if a system requires that data be read every 5ms, the device could be configured with the conversion times set to 588 μ s for both shunt and bus voltage measurements and the averaging mode set to 4. This configuration results in the data updating approximately every 4.7ms. The device could also be configured with a different conversion time setting for the shunt and bus voltage measurements. This type of approach is common in applications where the bus voltage tends to be relatively stable. This situation can allow for the time focused on the bus voltage measurement to be reduced relative to the shunt voltage measurement. The shunt voltage conversion time could be set to 4.156 ms with the bus voltage conversion time set to 588 μ s, with the averaging mode set to 1. This configuration also results in data updating approximately every 4.7 ms.

There are trade-offs associated with the settings for conversion time and the averaging mode used. The averaging feature can significantly improve the measurement accuracy by effectively filtering the signal. This approach allows the device to reduce any noise in the measurement that may be caused by noise coupling into the signal. A greater number of averages enables the device to be more effective in reducing the noise component of the measurement.

The conversion times selected can also have an impact on the measurement accuracy. [Figure 20](#) shows multiple conversion times to illustrate the impact of noise on the measurement. In order to achieve the highest accuracy measurement possible, use a combination of the longest allowable conversion times and highest number of averages, based on the timing requirements of the system.

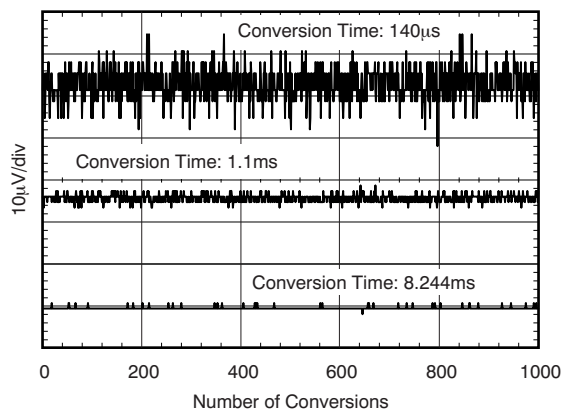

Figure 20. Noise vs Conversion Time

Device Functional Modes (continued)

7.4.2 Filtering and Input Considerations

Measuring current is often noisy, and such noise can be difficult to define. The INA226 device offers several options for filtering by allowing the conversion times and number of averages to be selected independently in the Configuration Register (00h). The conversion times can be set independently for the shunt voltage and bus voltage measurements to allow added flexibility in configuring the monitoring of the power-supply bus.

The internal ADC is based on a delta-sigma ($\Delta\Sigma$) front-end with a 500 kHz ($\pm 30\%$) typical sampling rate. This architecture has good inherent noise rejection; however, transients that occur at or very close to the sampling rate harmonics can cause problems. Because these signals are at 1 MHz and higher, they can be managed by incorporating filtering at the input of the device. The high frequency enables the use of low-value series resistors on the filter with negligible effects on measurement accuracy. In general, filtering the device input is only necessary if there are transients at exact harmonics of the 500 kHz ($\pm 30\%$) sampling rate (greater than 1 MHz). Filter using the lowest possible series resistance (typically 10 Ω or less) and a ceramic capacitor. Recommended values for this capacitor are between 0.1 μF and 1 μF . [Figure 21](#) shows the device with a filter added at the input.

Overload conditions are another consideration for the device inputs. The device inputs are specified to tolerate 40 V across the inputs. A large differential scenario might be a short to ground on the load side of the shunt. This type of event can result in full power-supply voltage across the shunt (as long the power supply or energy storage capacitors support it). Removing a short to ground can result in inductive kickbacks that could exceed the 40-V differential and common-mode rating of the device. Inductive kickback voltages are best controlled by Zener-type transient-absorbing devices (commonly called *transzorb*s) combined with sufficient energy storage capacitance. See the TI Design, *Transient Robustness for Current Shunt Monitors* ([TIDU473](#)), which describes a high-side current shunt monitor used to measure the voltage developed across a current-sensing resistor when current passes through it.

In applications that do not have large energy storage electrolytics on one or both sides of the shunt, an input overstress condition may result from an excessive dV/dt of the voltage applied to the input. A hard physical short is the most likely cause of this event, particularly in applications with no large electrolytics present. This problem occurs because an excessive dV/dt can activate the ESD protection in the device in systems where large currents are available. Testing demonstrates that the addition of 10- Ω resistors in series with each input of the device sufficiently protects the inputs against this dV/dt failure up to the 40-V rating of the device. Selecting these resistors in the range noted has minimal effect on accuracy.

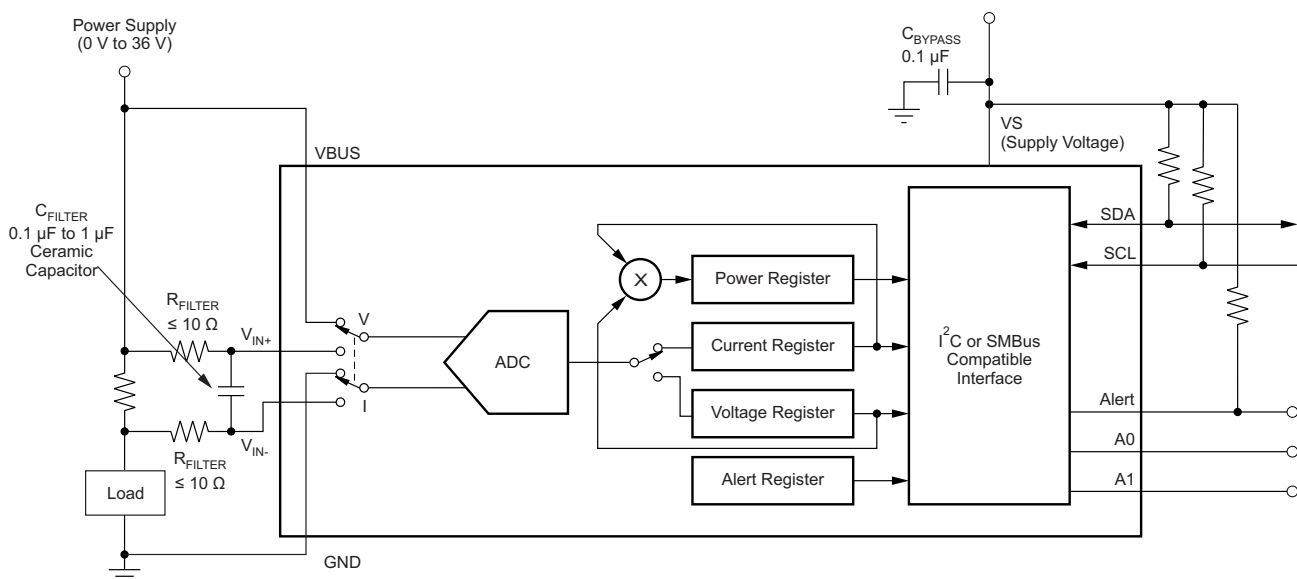

Figure 21. Input Filtering

7.5 Programming

An important aspect of the INA226 device is that it does not necessarily measure current or power. The device measures both the differential voltage applied between the IN+ and IN- input pins and the voltage applied to the VBUS pin. In order for the device to report both current and power values, the user must program the resolution of the Current Register (04h) and the value of the shunt resistor present in the application to develop the differential voltage applied between the input pins. The Power Register (03h) is internally set to be 25 times the programmed Current_LSB. Both the Current_LSB and shunt resistor value are used in the calculation of the Calibration Register value the device uses to calculate the corresponding current and power values based on the measured shunt and bus voltages.

The Calibration Register is calculated based on [Equation 1](#). This equation includes the term Current_LSB, which is the programmed value for the LSB for the Current Register (04h). The user uses this value to convert the value in the Current Register (04h) to the actual current in amperes. The highest resolution for the Current Register (04h) can be obtained by using the smallest allowable Current_LSB based on the maximum expected current as shown in [Equation 2](#). While this value yields the highest resolution, it is common to select a value for the Current_LSB to the nearest round number above this value to simplify the conversion of the Current Register (04h) and Power Register (03h) to amperes and watts respectively. The R_{SHUNT} term is the value of the external shunt used to develop the differential voltage across the input pins.

$$CAL = \frac{0.00512}{Current_LSB \cdot R_{SHUNT}}$$

where

- 0.00512 is an internal fixed value used to ensure scaling is maintained properly (1)

$$Current_LSB = \frac{Maximum\ Expected\ Current}{2^{15}} \tag{2}$$

After programming the Calibration Register, the Current Register (04h) and Power Register (03h) update accordingly based on the corresponding shunt voltage and bus voltage measurements. Until the Calibration Register is programmed, the Current Register (04h) and Power Register (03h) remain at zero.

7.5.1 Programming the Calibration Register

[Figure 27](#) shows a nominal 10-A load that creates a differential voltage of 20 mV across a 2-mΩ shunt resistor. The bus voltage for the INA226 is measured at the external VBUS input pin, which in this example is connected to the IN- pin to measure the voltage level delivered to the load. For this example, the VBUS pin measures less than 12 V because the voltage at the IN- pin is 11.98 V as a result of the voltage drop across the shunt resistor.

For this example, assuming a maximum expected current of 15 A, the Current_LSB is calculated to be 457.7 μA/bit using [Equation 2](#). Using a value for the Current_LSB of 500 μA/Bit or 1 mA/Bit would significantly simplify the conversion from the Current Register (04h) and Power Register (03h) to amperes and watts. For this example, a value of 1 mA/bit was chosen for the Current_LSB. Using this value for the Current_LSB does trade a small amount of resolution for having a simpler conversion process on the user side. Using [Equation 1](#) in this example with a Current_LSB value of 1 mA/bit and a shunt resistor of 2 mΩ results in a Calibration Register value of 2560, or A00h.

The Current Register (04h) is then calculated by multiplying the decimal value of the Shunt Voltage Register (01h) contents by the decimal value of the Calibration Register and then dividing by 2048, as shown in [Equation 3](#). For this example, the Shunt Voltage Register contains a value of 8,000 (representing 20 mV), which is multiplied by the Calibration Register value of 2560 and then divided by 2048 to yield a decimal value for the Current Register (04h) of 10000, or 2710h. Multiplying this value by 1 mA/bit results in the original 10-A level stated in the example.

$$Current = \frac{ShuntVoltage \cdot CalibrationRegister}{2048} \tag{3}$$

Programming (continued)

The LSB for the Bus Voltage Register (02h) is a fixed 1.25 mV/bit, which means that the 11.98 V present at the VBUS pin results in a register value of 2570h, or a decimal equivalent of 9584. Note that the MSB of the Bus Voltage Register (02h) is always zero because the VBUS pin is only able to measure positive voltages.

The Power Register (03h) is then be calculated by multiplying the decimal value of the Current Register, 10000, by the decimal value of the Bus Voltage Register (02h), 9584, and then dividing by 20,000, as defined in [Equation 4](#). For this example, the result for the Power Register (03h) is 12B8h, or a decimal equivalent of 4792. Multiplying this result by the power LSB (25 times the [1×10^{-3} Current_LSB]) results in a power calculation of (4792×25 mW/bit), or 119.82 W. The power LSB has a fixed ratio to the Current_LSB of 25. For this example, a programmed 1 mA/bit Current_LSB results in a power LSB of 25 mW/bit. This ratio is internally programmed to ensure that the scaling of the power calculation is within an acceptable range. A manual calculation for the power being delivered to the load would use a bus voltage of 11.98 V ($12 V_{CM} - 20$ mV shunt drop) multiplied by the load current of 10 A to give a result of 119.8 W.

$$\text{Power} = \frac{\text{Current} \cdot \text{BusVoltage}}{20,000} \quad (4)$$

[Table 1](#) lists the steps for configuring, measuring, and calculating the values for current and power for this device.

Table 1. Calculating Current and Power⁽¹⁾

STEP	REGISTER NAME	ADDRESS	CONTENTS	DEC	LSB	VALUE
Step 1	Configuration Register	00h	4127h	—	—	—
Step 2	Shunt Register	01h	1F40h	8000	2.5 μ V	20 mV
Step 3	Bus Voltage Register	02h	2570h	9584	1.25 mV	11.98 V
Step 4	Calibration Register	05h	A00h	2560	—	—
Step 5	Current Register	04h	2710	10000	1 mA	10 A
Step 6	Power Register	03h	12B8h	4792	25 mW	119.82 W

(1) Conditions: Load = 10 A, $V_{CM} = 12$ V, $R_{SHUNT} = 2$ m Ω , and $V_{VBUS} = 12$ V.

7.5.2 Programming the Power Measurement Engine

7.5.2.1 Calibration Register and Scaling

The Calibration Register enables the user to scale the Current Register (04h) and Power Register (03h) to the most useful value for a given application. For example, set the Calibration Register such that the largest possible number is generated in the Current Register (04h) or Power Register (03h) at the expected full-scale point. This approach yields the highest resolution using the previously calculated minimum Current_LSB in the equation for the Calibration Register. The Calibration Register can also be selected to provide values in the Current Register (04h) and Power Register (03h) that either provide direct decimal equivalents of the values being measured, or yield a round LSB value for each corresponding register. After these choices have been made, the Calibration Register also offers possibilities for end user system-level calibration. After determining the exact current by using an external ammeter, the value of the Calibration Register can then be adjusted based on the measured current result of the INA226 to cancel the total system error as shown in [Equation 5](#).

$$\text{Corrected_Full_Scale_Cal} = \text{trunc} \left(\frac{\text{Cal} \times \text{MeasShuntCurrent}}{\text{INA226_Current}} \right) \quad (5)$$

7.5.3 Simple Current Shunt Monitor Usage (No Programming Necessary)

The device can be used without any programming if it is only necessary to read a shunt voltage drop and bus voltage with the default power-on reset configuration and continuous conversion of shunt and bus voltages.

Without programming the device Calibration Register, the device is unable to provide either a valid current or power value, because these outputs are both derived using the values loaded into the Calibration Register.

7.5.4 Default Settings

The default power-up states of the registers are shown in the [Register Maps](#) section of this data sheet. These registers are volatile, and if programmed to a value other than the default values shown in [Table 4](#), they must be re-programmed at every device power-up. Detailed information on programming the Calibration Register specifically is given in the [Programming](#) section and calculated based on [Equation 1](#).

7.5.5 Bus Overview

The INA226 offers compatibility with both I²C and SMBus interfaces. The I²C and SMBus protocols are essentially compatible with one another.

The I²C interface is used throughout this data sheet as the primary example, with SMBus protocol specified only when a difference between the two systems is discussed. Two lines, SCL and SDA, connect the device to the bus. Both SCL and SDA are open-drain connections.

The device that initiates a data transfer is called a *master*, and the devices controlled by the master are *slaves*. The bus must be controlled by a master device that generates the serial clock (SCL), controls the bus access, and generates START and STOP conditions.

To address a specific device, the master initiates a start condition by pulling the data signal line (SDA) from a high to a low logic level while SCL is high. All slaves on the bus shift in the slave address byte on the rising edge of SCL, with the last bit indicating whether a read or write operation is intended. During the ninth clock pulse, the slave being addressed responds to the master by generating an Acknowledge and pulling SDA low.

Data transfer is then initiated and eight bits of data are sent, followed by an *Acknowledge* bit. During data transfer, SDA must remain stable while SCL is high. Any change in SDA while SCL is high is interpreted as a start or stop condition.

After all data have been transferred, the master generates a stop condition, indicated by pulling SDA from low to high while SCL is high. The device includes a 28 ms timeout on its interface to prevent locking up the bus.

7.5.5.1 Serial Bus Address

To communicate with the INA226, the master must first address slave devices via a slave address byte. The slave address byte consists of seven address bits and a direction bit that indicates whether the action is to be a read or write operation.

The device has two address pins, A0 and A1. [Table 2](#) lists the pin logic levels for each of the 16 possible addresses. The device samples the state of pins A0 and A1 on every bus communication. Establish the pin states before any activity on the interface occurs.

Table 2. Address Pins and Slave Addresses

A1	A0	SLAVE ADDRESS
GND	GND	1000000
GND	VS	1000001
GND	SDA	1000010
GND	SCL	1000011
VS	GND	1000100
VS	VS	1000101
VS	SDA	1000110
VS	SCL	1000111
SDA	GND	1001000
SDA	VS	1001001
SDA	SDA	1001010
SDA	SCL	1001011
SCL	GND	1001100
SCL	VS	1001101
SCL	SDA	1001110
SCL	SCL	1001111

7.5.5.2 Serial Interface

The INA226 operates only as a slave device on both the I²C bus and the SMBus. Connections to the bus are made via the open-drain SDA and SCL lines. The SDA and SCL pins feature integrated spike suppression filters and Schmitt triggers to minimize the effects of input spikes and bus noise. Although the device integrates spike suppression into the digital I/O lines, proper layout techniques help minimize the amount of coupling into the communication lines. This noise introduction could occur from capacitively coupling signal edges between the two communication lines themselves or from other switching noise sources present in the system. Routing traces in parallel with ground in between layers on a printed circuit board (PCB) typically reduces the effects of coupling between the communication lines. Shielded communication lines reduces the possibility of unintended noise coupling into the digital I/O lines that could be incorrectly interpreted as start or stop commands.

The INA226 supports the transmission protocol for fast mode (1 kHz to 400 kHz) and high-speed mode (1 kHz to 2.94 MHz). All data bytes are transmitted most significant byte first.

7.5.5.3 Writing to and Reading from the INA226

Accessing a specific register on the INA226 is accomplished by writing the appropriate value to the register pointer. Refer to [Table 4](#) for a complete list of registers and corresponding addresses. The value for the register pointer (as shown in [Figure 25](#)) is the first byte transferred after the slave address byte with the R/W bit low. Every write operation to the device requires a value for the register pointer.

Writing to a register begins with the first byte transmitted by the master. This byte is the slave address, with the R/W bit low. The device then acknowledges receipt of a valid address. The next byte transmitted by the master is the address of the register which data is written to. This register address value updates the register pointer to the desired register. The next two bytes are written to the register addressed by the register pointer. The device acknowledges receipt of each data byte. The master may terminate data transfer by generating a start or stop condition.

When reading from the device, the last value stored in the register pointer by a write operation determines which register is read during a read operation. To change the register pointer for a read operation, a new value must be written to the register pointer. This write is accomplished by issuing a slave address byte with the R/W bit low, followed by the register pointer byte. No additional data are required. The master then generates a start condition and sends the slave address byte with the R/W bit high to initiate the read command. The next byte is transmitted by the slave and is the most significant byte of the register indicated by the register pointer. This byte is followed by an *Acknowledge* from the master; then the slave transmits the least significant byte. The master acknowledges receipt of the data byte. The master may terminate data transfer by generating a *Not-Acknowledge* after receiving any data byte, or generating a start or stop condition. If repeated reads from the same register are desired, it is not necessary to continually send the register pointer bytes; the device retains the register pointer value until it is changed by the next write operation.

Figure 22 shows the write operation timing diagram. Figure 23 shows the read operation timing diagram.

NOTE

Register bytes are sent most-significant byte first, followed by the least significant byte.

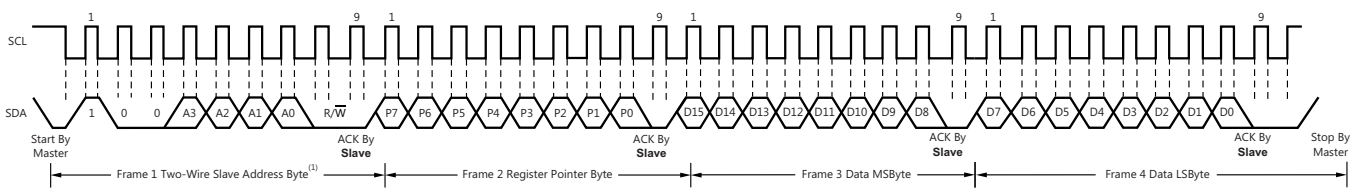

(1) The value of the Slave Address byte is determined by the settings of the A0 and A1 pins. Refer to Table 2.

Figure 22. Timing Diagram for Write Word Format

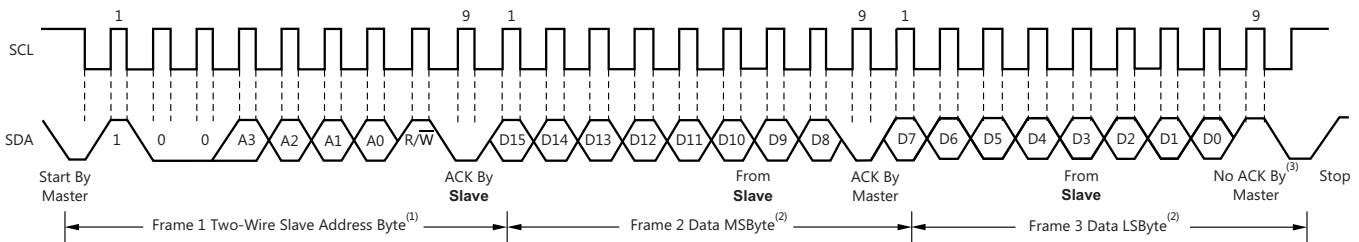

(1) The value of the Slave Address byte is determined by the settings of the A0 and A1 pins. Refer to Table 2.

(2) Read data is from the last register pointer location. If a new register is desired, the register pointer must be updated. See Figure 25.

(3) ACK by Master can also be sent.

Figure 23. Timing Diagram for Read Word Format

Figure 24 shows the timing diagram for the SMBus Alert response operation. Figure 25 illustrates a typical register pointer configuration.

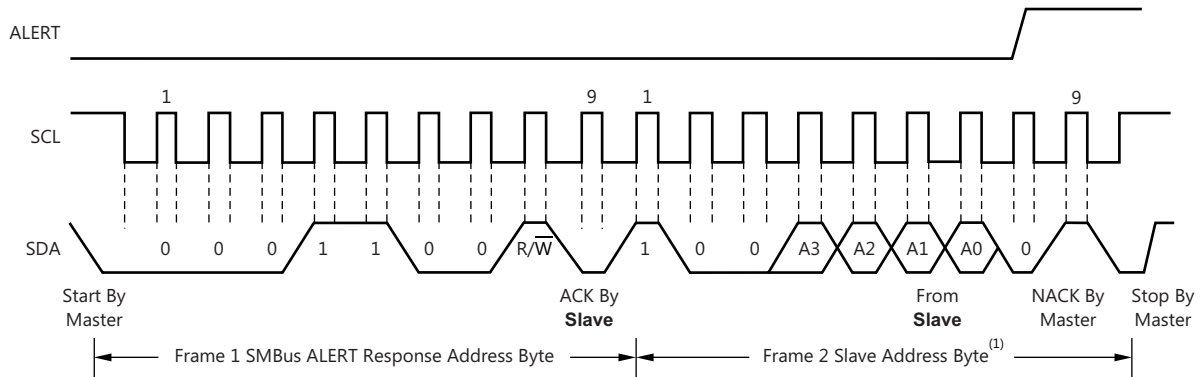

(1) The value of the Slave Address Byte is determined by the settings of the A0 and A1 pins. Refer to Table 2.

Figure 24. Timing Diagram for SMBus ALERT

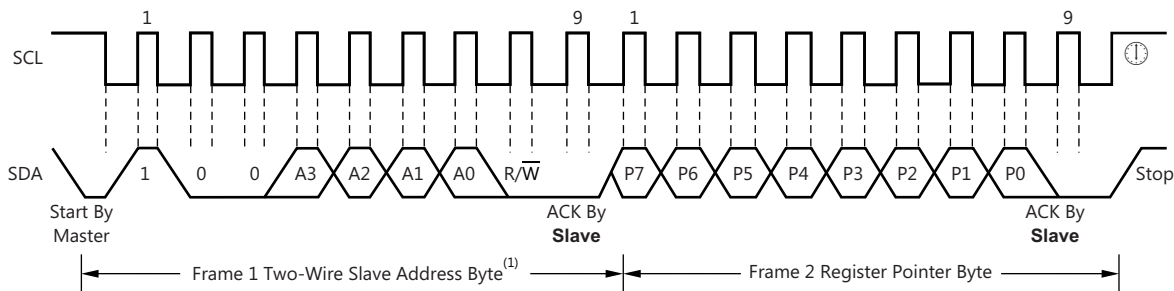

(1) The value of the Slave Address Byte is determined by the settings of the A0 and A1 pins. Refer to Table 2.

Figure 25. Typical Register Pointer Set

7.5.5.3.1 High-Speed I²C Mode

When the bus is idle, both the SDA and SCL lines are pulled high by the pullup resistors. The master generates a start condition followed by a valid serial byte containing high-speed (HS) master code 00001XXX. This transmission is made in fast (400 kHz) or standard (100 kHz) (F/S) mode at no more than 400 kHz. The device does not acknowledge the HS master code, but does recognize it and switches its internal filters to support 2.94 MHz operation.

The master then generates a repeated start condition (a repeated start condition has the same timing as the start condition). After this repeated start condition, the protocol is the same as F/S mode, except that transmission speeds up to 2.94 MHz are allowed. Instead of using a stop condition, use repeated start conditions to secure the bus in HS-mode. A stop condition ends the HS-mode and switches all the internal filters of the device to support the F/S mode.

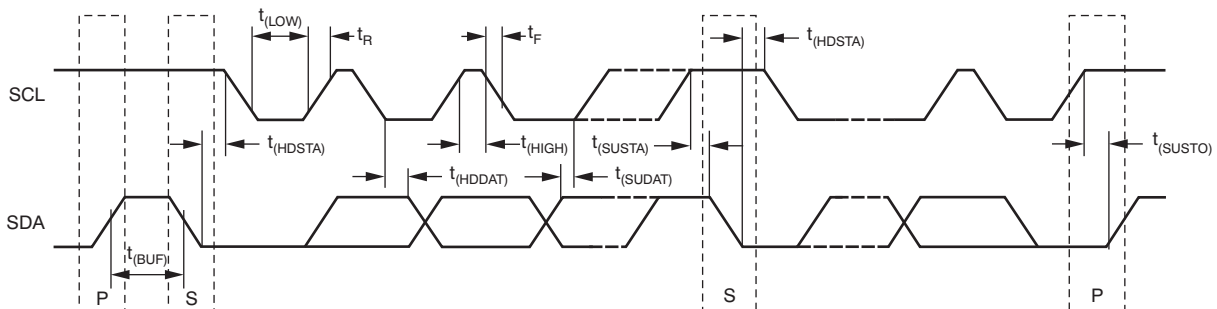

Figure 26. Bus Timing Diagram

Table 3. Bus Timing Diagram Definitions⁽¹⁾

PARAMETER		FAST MODE		HIGH-SPEED MODE		UNIT
		MIN	MAX	MIN	MAX	
SCL operating frequency	$f_{(SCL)}$	0.001	0.4	0.001	2.94	MHz
Bus free time between stop and start conditions	$t_{(BUF)}$	600		160		ns
Hold time after repeated START condition. After this period, the first clock is generated.	$t_{(HDSTA)}$	100		100		ns
Repeated start condition setup time	$t_{(SUSTA)}$	100		100		ns
STOP condition setup time	$t_{(SUSTO)}$	100		100		ns
Data hold time	$t_{(HDDAT)}$	10	900	10	100	ns
Data setup time	$t_{(SUDAT)}$	100		20		ns
SCL clock low period	$t_{(LOW)}$	1300		200		ns
SCL clock high period	$t_{(HIGH)}$	600		60		ns
Data fall time	t_F		300		80	ns
Clock fall time	t_F		300		40	ns
Clock rise time	t_R		300		40	ns
Clock/data rise time for SCLK \leq 100kHz	t_R		1000			ns

(1) Values based on a statistical analysis of a one-time sample of devices. Minimum and maximum values are not guaranteed and not production tested.

7.5.5.4 SMBus Alert Response

The INA226 is designed to respond to the SMBus Alert Response address. The SMBus Alert Response provides a quick fault identification for simple slave devices. When an Alert occurs, the master can broadcast the Alert Response slave address (0001 100) with the Read/Write bit set high. Following this Alert Response, any slave device that generates an alert identifies itself by acknowledging the Alert Response and sending its address on the bus.

The Alert Response can activate several different slave devices simultaneously, similar to the I²C General Call. If more than one slave attempts to respond, bus arbitration rules apply. The losing device does not generate an Acknowledge and continues to hold the Alert line low until the interrupt is cleared.

7.6 Register Maps

The INA226 uses a bank of registers for holding configuration settings, measurement results, minimum/maximum limits, and status information. [Table 4](#) summarizes the device registers; refer to the [Functional Block Diagram](#) section for an illustration of the registers.

All 16-bit device registers are two 8-bit bytes via the I²C interface.

Table 4. Register Set Summary

POINTER ADDRESS	REGISTER NAME	FUNCTION	POWER-ON RESET		TYPE ⁽¹⁾
			BINARY	HEX	
00h	Configuration Register	All-register reset, shunt voltage and bus voltage ADC conversion times and averaging, operating mode.	01000001 00100111	4127	R/ \bar{W}
01h	Shunt Voltage Register	Shunt voltage measurement data.	00000000 00000000	0000	R
02h	Bus Voltage Register	Bus voltage measurement data.	00000000 00000000	0000	R
03h	Power Register ⁽²⁾	Contains the value of the calculated power being delivered to the load.	00000000 00000000	0000	R
04h	Current Register ⁽²⁾	Contains the value of the calculated current flowing through the shunt resistor.	00000000 00000000	0000	R

(1) Type: R = Read-Only, R/ \bar{W} = Read/Write.

(2) The Current Register (04h) and Power Register (03h) default to '0' because the Calibration register defaults to '0', yielding zero current and power values until the Calibration register is programmed.

Register Maps (continued)
Table 4. Register Set Summary (continued)

POINTER ADDRESS	REGISTER NAME	FUNCTION	POWER-ON RESET		TYPE ⁽¹⁾
			BINARY	HEX	
05h	Calibration Register	Sets full-scale range and LSB of current and power measurements. Overall system calibration.	00000000 00000000	0000	R/W
06h	Mask/Enable Register	Alert configuration and Conversion Ready flag.	00000000 00000000	0000	R/W
07h	Alert Limit Register	Contains the limit value to compare to the selected Alert function.	00000000 00000000	0000	R/W
FEh	Manufacturer ID Register	Contains unique manufacturer identification number.	0101010001001001	5449	R
FFh	Die ID Register	Contains unique die identification number.	0010001001100000	2260	R

7.6.1 Configuration Register (00h) (Read/Write)
Table 5. Configuration Register (00h) (Read/Write) Descriptions

BIT NO.	D15	D14	D13	D12	D11	D10	D9	D8	D7	D6	D5	D4	D3	D2	D1	D0
BIT NAME	RST	—	—	—	AVG2	AVG1	AVG0	VBUSCT2	VBUSCT1	VBUSCT0	VSHCT2	VSHCT1	VSHCT0	MODE3	MODE2	MODE1
POR VALUE	0	1	0	0	0	0	0	1	0	0	1	0	0	1	1	1

The Configuration Register settings control the operating modes for the device. This register controls the conversion time settings for both the shunt and bus voltage measurements as well as the averaging mode used. The operating mode that controls what signals are selected to be measured is also programmed in the Configuration Register .

The Configuration Register can be read from at any time without impacting or affecting the device settings or a conversion in progress. Writing to the Configuration Register halts any conversion in progress until the write sequence is completed resulting in a new conversion starting based on the new contents of the Configuration Register (00h). This halt prevents any uncertainty in the conditions used for the next completed conversion.

- RST:** **Reset Bit**
 Bit 15
 Setting this bit to '1' generates a system reset that is the same as power-on reset. Resets all registers to default values; this bit self-clears.
- AVG:** **Averaging Mode**
 Bits 9–11
 Determines the number of samples that are collected and averaged. [Table 6](#) shows all the AVG bit settings and related number of averages for each bit setting.

Table 6. AVG Bit Settings[11:9] Combinations

AVG2 D11	AVG1 D10	AVG0 D9	NUMBER OF AVERAGES ⁽¹⁾
0	0	0	1
0	0	1	4
0	1	0	16
0	1	1	64
1	0	0	128
1	0	1	256
1	1	0	512
1	1	1	1024

(1) Shaded values are default.

VBUSCT:

Bits 6–8

Bus Voltage Conversion Time

Sets the conversion time for the bus voltage measurement. [Table 7](#) shows the VBUSCT bit options and related conversion times for each bit setting.

Table 7. VBUSCT Bit Settings [8:6] Combinations

VBUSCT2 D8	VBUSCT1 D7	VBUSCT0 D6	CONVERSION TIME ⁽¹⁾
0	0	0	140 μ s
0	0	1	204 μ s
0	1	0	332 μ s
0	1	1	588 μ s
1	0	0	1.1 ms
1	0	1	2.116 ms
1	1	0	4.156 ms
1	1	1	8.244 ms

(1) Shaded values are default.

VSHCT:

Bits 3–5

Shunt Voltage Conversion Time

Sets the conversion time for the shunt voltage measurement. [Table 8](#) shows the VSHCT bit options and related conversion times for each bit setting.

Table 8. VSHCT Bit Settings [5:3] Combinations

VSHCT2 D8	VSHCT1 D7	VSHCT0 D6	CONVERSION TIME ⁽¹⁾
0	0	0	140 μ s
0	0	1	204 μ s
0	1	0	332 μ s
0	1	1	588 μ s
1	0	0	1.1 ms
1	0	1	2.116 ms
1	1	0	4.156 ms
1	1	1	8.244 ms

(1) Shaded values are default.

MODE:

Bits 0-2

Operating Mode

Selects continuous, triggered, or power-down mode of operation. These bits default to continuous shunt and bus measurement mode. The mode settings are shown in [Table 9](#).

Table 9. Mode Settings [2:0] Combinations

MODE3 D2	MODE2 D1	MODE1 D0	MODE ⁽¹⁾
0	0	0	Power-Down (or Shutdown)
0	0	1	Shunt Voltage, Triggered
0	1	0	Bus Voltage, Triggered
0	1	1	Shunt and Bus, Triggered
1	0	0	Power-Down (or Shutdown)
1	0	1	Shunt Voltage, Continuous
1	1	0	Bus Voltage, Continuous
1	1	1	Shunt and Bus, Continuous

(1) Shaded values are default.

7.6.2 Shunt Voltage Register (01h) (Read-Only)

The Shunt Voltage Register stores the current shunt voltage reading, V_{SHUNT} . Negative numbers are represented in two's complement format. Generate the two's complement of a negative number by complementing the absolute value binary number and adding 1. An MSB = '1' denotes a negative number.

Example: For a value of $V_{SHUNT} = -80$ mV:

1. Take the absolute value: 80 mV
2. Translate this number to a whole decimal number ($80 \text{ mV} \div 2.5 \mu\text{V} = 32000$)
3. Convert this number to binary = 0111 1101 0000 0000
4. Complement the binary result = 1000 0010 1111 1111
5. Add '1' to the complement to create the two's complement result = 1000 0011 0000 0000 = 8300h

If averaging is enabled, this register displays the averaged value.

Full-scale range = 81.92 mV (decimal = 7FFF); LSB: 2.5 μV .

Table 10. Shunt Voltage Register (01h) (Read-Only) Description

BIT #	D15	D14	D13	D12	D11	D10	D9	D8	D7	D6	D5	D4	D3	D2	D1	D0
BIT NAME	SIGN	SD14	SD13	SD12	SD11	SD10	SD9	SD8	SD7	SD6	SD5	SD4	SD3	SD2	SD1	SD0
POR VALUE	0	0	0	0	0	0	0	0	0	0	0	0	0	0	0	0

7.6.3 Bus Voltage Register (02h) (Read-Only) ⁽¹⁾

The Bus Voltage Register stores the most recent bus voltage reading, V_{BUS} .

If averaging is enabled, this register displays the averaged value.

Full-scale range = 40.96 V (decimal = 7FFF); LSB = 1.25 mV.

Table 11. Bus Voltage Register (02h) (Read-Only) Description

BIT #	D15	D14	D13	D12	D11	D10	D9	D8	D7	D6	D5	D4	D3	D2	D1	D0
BIT NAME	—	BD14	BD13	BD12	BD11	BD10	BD9	BD8	BD7	BD6	BD5	BD4	BD3	BD2	BD1	BD0
POR VALUE	0	0	0	0	0	0	0	0	0	0	0	0	0	0	0	0

(1) D15 is always zero because bus voltage can only be positive.

7.6.4 Power Register (03h) (Read-Only)

If averaging is enabled, this register displays the averaged value.

The Power Register LSB is internally programmed to equal 25 times the programmed value of the Current_LSB.

The Power Register records power in Watts by multiplying the decimal values of the Current Register with the decimal value of the Bus Voltage Register according to [Equation 4](#).

Table 12. Power Register (03h) (Read-Only) Description

BIT #	D15	D14	D13	D12	D11	D10	D9	D8	D7	D6	D5	D4	D3	D2	D1	D0
BIT NAME	PD15	PD14	PD13	PD12	PD11	PD10	PD9	PD8	PD7	PD6	PD5	PD4	PD3	PD2	PD1	PD0
POR VALUE	0	0	0	0	0	0	0	0	0	0	0	0	0	0	0	0

7.6.5 Current Register (04h) (Read-Only)

If averaging is enabled, this register displays the averaged value.

The value of the Current Register is calculated by multiplying the decimal value in the Shunt Voltage Register with the decimal value of the Calibration Register, according to [Equation 3](#).

Table 13. Current Register (04h) (Read-Only) Register Description

BIT #	D15	D14	D13	D12	D11	D10	D9	D8	D7	D6	D5	D4	D3	D2	D1	D0
BIT NAME	CSIGN	CD14	CD13	CD12	CD11	CD10	CD9	CD8	CD7	CD6	CD5	CD4	CD3	CD2	CD1	CD0
POR VALUE	0	0	0	0	0	0	0	0	0	0	0	0	0	0	0	0

7.6.6 Calibration Register (05h) (Read/Write)

This register provides the device with the value of the shunt resistor that was present to create the measured differential voltage. It also sets the resolution of the Current Register. Programming this register sets the Current_LSB and the Power_LSB. This register is also suitable for use in overall system calibration. See the [Programming the Calibration Register](#) for additional information on programming the Calibration Register.

Table 14. Calibration Register (05h) (Read/Write) Description

BIT #	D15	D14	D13	D12	D11	D10	D9	D8	D7	D6	D5	D4	D3	D2	D1	D0
BIT NAME	—	FS14	FS13	FS12	FS11	FS10	FS9	FS8	FS7	FS6	FS5	FS4	FS3	FS2	FS1	FS0
POR VALUE	0	0	0	0	0	0	0	0	0	0	0	0	0	0	0	0

7.6.7 Mask/Enable Register (06h) (Read/Write)

The Mask/Enable Register selects the function that is enabled to control the Alert pin as well as how that pin functions. If multiple functions are enabled, the highest significant bit position Alert Function (D15-D11) takes priority and responds to the Alert Limit Register.

Table 15. Mask/Enable Register (06h) (Read/Write)

BIT #	D15	D14	D13	D12	D11	D10	D9	D8	D7	D6	D5	D4	D3	D2	D1	D0
BIT NAME	SOL	SUL	BOL	BUL	POL	CNVR	—	—	—	—	—	AFF	CVRF	OVF	APOL	LEN
POR VALUE	0	0	0	0	0	0	0	0	0	0	0	0	0	0	0	0

SOL: Shunt Voltage Over-Voltage

Bit 15 Setting this bit high configures the Alert pin to be asserted if the shunt voltage measurement following a conversion exceeds the value programmed in the Alert Limit Register.

SUL: Shunt Voltage Under-Voltage

Bit 14 Setting this bit high configures the Alert pin to be asserted if the shunt voltage measurement following a conversion drops below the value programmed in the Alert Limit Register.

BOL: Bus Voltage Over-Voltage

Bit 13 Setting this bit high configures the Alert pin to be asserted if the bus voltage measurement following a conversion exceeds the value programmed in the Alert Limit Register.

BUL: Bus Voltage Under-Voltage

Bit 12 Setting this bit high configures the Alert pin to be asserted if the bus voltage measurement following a conversion drops below the value programmed in the Alert Limit Register.

POL: Power Over-Limit

Bit 11 Setting this bit high configures the Alert pin to be asserted if the Power calculation made following a bus voltage measurement exceeds the value programmed in the Alert Limit Register.

CNVR: Conversion Ready

Bit 10 Setting this bit high configures the Alert pin to be asserted when the Conversion Ready Flag, Bit 3, is asserted indicating that the device is ready for the next conversion.

AFF:	Alert Function Flag
Bit 4	<p>While only one Alert Function can be monitored at the Alert pin at a time, the Conversion Ready can also be enabled to assert the Alert pin. Reading the Alert Function Flag following an alert allows the user to determine if the Alert Function was the source of the Alert.</p> <p>When the Alert Latch Enable bit is set to Latch mode, the Alert Function Flag bit clears only when the Mask/Enable Register is read. When the Alert Latch Enable bit is set to Transparent mode, the Alert Function Flag bit is cleared following the next conversion that does not result in an Alert condition.</p>
CVRF:	Conversion Ready Flag
Bit 3	<p>Although the device can be read at any time, and the data from the last conversion is available, the Conversion Ready Flag bit is provided to help coordinate one-shot or triggered conversions. The Conversion Ready Flag bit is set after all conversions, averaging, and multiplications are complete. Conversion Ready Flag bit clears under the following conditions:</p> <ol style="list-style-type: none"> 1.) Writing to the Configuration Register (except for Power-Down selection) 2.) Reading the Mask/Enable Register
OVF:	Math Overflow Flag
Bit 2	<p>This bit is set to '1' if an arithmetic operation resulted in an overflow error. It indicates that current and power data may be invalid.</p>
APOL:	Alert Polarity bit; sets the Alert pin polarity.
Bit 1	<p>1 = Inverted (active-high open collector) 0 = Normal (active-low open collector) (default)</p>
LEN:	Alert Latch Enable; configures the latching feature of the Alert pin and Alert Flag bits.
Bit 0	<p>1 = Latch enabled 0 = Transparent (default)</p> <p>When the Alert Latch Enable bit is set to Transparent mode, the Alert pin and Flag bit resets to the idle states when the fault has been cleared. When the Alert Latch Enable bit is set to Latch mode, the Alert pin and Alert Flag bit remains active following a fault until the Mask/Enable Register has been read.</p>

7.6.8 Alert Limit Register (07h) (Read/Write)

The Alert Limit Register contains the value used to compare to the register selected in the Mask/Enable Register to determine if a limit has been exceeded.

Table 16. Alert Limit Register (07h) (Read/Write) Description

BIT #	D15	D14	D13	D12	D11	D10	D9	D8	D7	D6	D5	D4	D3	D2	D1	D0
BIT NAME	AUL15	AUL14	AUL13	AUL12	AUL11	AUL10	AUL9	AUL8	AUL7	AUL6	AUL5	AUL4	AUL3	AUL2	AUL1	AUL0
POR VALUE	0	0	0	0	0	0	0	0	0	0	0	0	0	0	0	0

7.6.9 Manufacturer ID Register (FEh) (Read-Only)

The Manufacturer ID Register stores a unique identification number for the manufacturer.

Table 17. Manufacturer ID Register (FEh) (Read-Only) Description

BIT #	D15	D14	D13	D12	D11	D10	D9	D8	D7	D6	D5	D4	D3	D2	D1	D0
BIT NAME	ID15	ID14	ID13	ID12	ID11	ID10	ID9	ID8	ID7	ID6	ID5	ID4	ID3	ID2	ID1	ID0
POR VALUE	0	1	0	1	0	1	0	0	0	1	0	0	1	0	0	1

ID:	Manufacturer ID Bits
Bits 0-15	Stores the manufacturer identification bits

7.6.10 Die ID Register (FFh) (Read-Only)

The Die ID Register stores a unique identification number and the revision ID for the die.

Table 18. Die ID Register (FFh) (Read-Only) Description

BIT #	D15	D14	D13	D12	D11	D10	D9	D8	D7	D6	D5	D4	D3	D2	D1	D0
BIT NAME	DID11	DID10	DID9	DID8	DID7	DID6	DID5	DID4	DID3	DID2	DID1	DID0	RID3	RID2	RID1	RID0
POR VALUE	0	0	0	0	0	0	0	0	0	0	0	0	0	0	0	0

DID: **Device ID Bits**
 Bits 4-15 Stores the device identification bits

RID: **Die Revision ID Bits**
 Bit 0-3 Stores the device revision identification bits

8 Application and Implementation

NOTE

Information in the following applications sections is not part of the TI component specification, and TI does not warrant its accuracy or completeness. TI's customers are responsible for determining suitability of components for their purposes. Validate and test the design implementation to confirm system functionality.

8.1 Application Information

The INA226 is a current shunt and power monitor with an I²C™ compatible interface. The device monitors both a shunt voltage drop and bus supply voltage. Programmable calibration value, conversion times, and averaging, combined with an internal multiplier, enable direct readouts of current in amperes and power in watts.

8.2 Typical Applications

8.2.1 High-Side Sensing Circuit Application

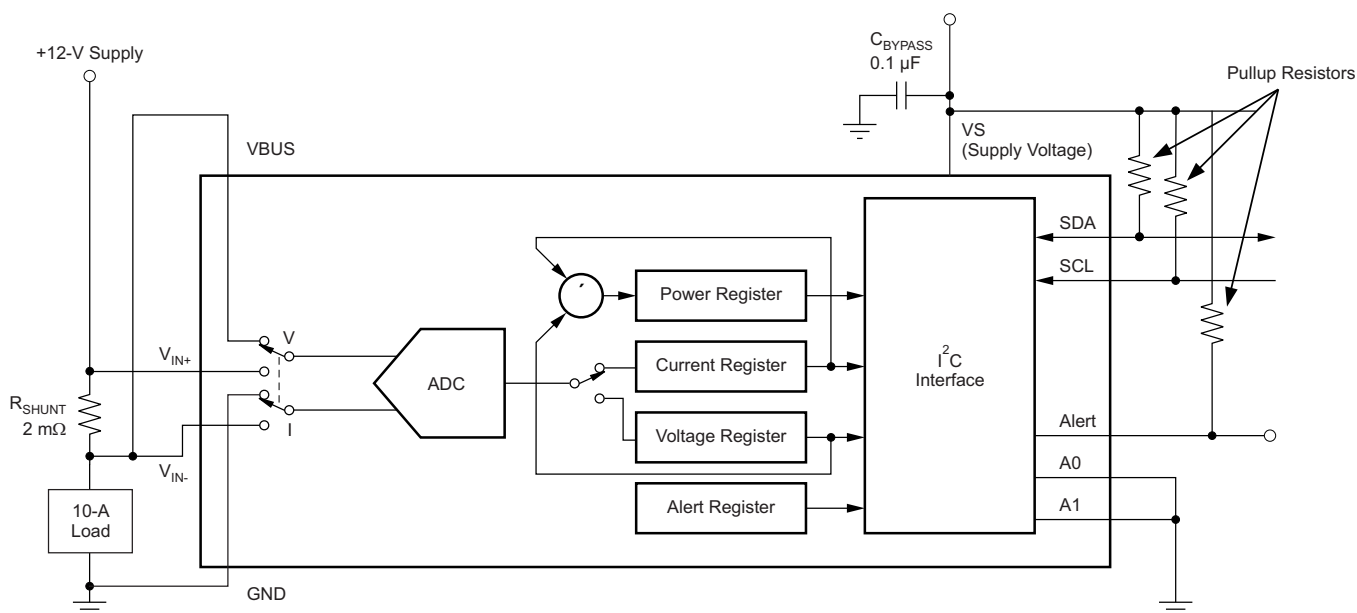

Figure 27. Typical Circuit Configuration, INA226

8.2.1.1 Design Requirements

INA226 measures the voltage developed across a current-sensing resistor (R_{SHUNT}) when current passes through it. The device also measures the bus supply voltage and can calculate power when calibrated. It comes with alert capability where the alert pin can be programmed to respond to a user-defined event or to a conversion ready notification. This design illustrates the ability of the alert pin to respond to a set threshold.

Typical Applications (continued)

8.2.1.2 Detailed Design Procedure

The Alert pin can be configured to respond to one of the five alert functions described in the [Alert Pin](#) section. The alert pin must to be pulled up to the V_{VS} pin voltage via the pull-up resistors. The configuration register is set based on the required conversion time and averaging. The Mask/Enable Register is set to identify the required alert function and the Alert Limit Register is set to the limit value used for comparison.

8.2.1.3 Application Curves

Figure 28 shows the Alert pin response to a shunt voltage over-limit of 80 mV for a conversion time (t_{CT}) of 1.1 ms and averaging set to 1. Figure 29 shows the response for the same limit but with the conversion time reduced to 140 μ s.

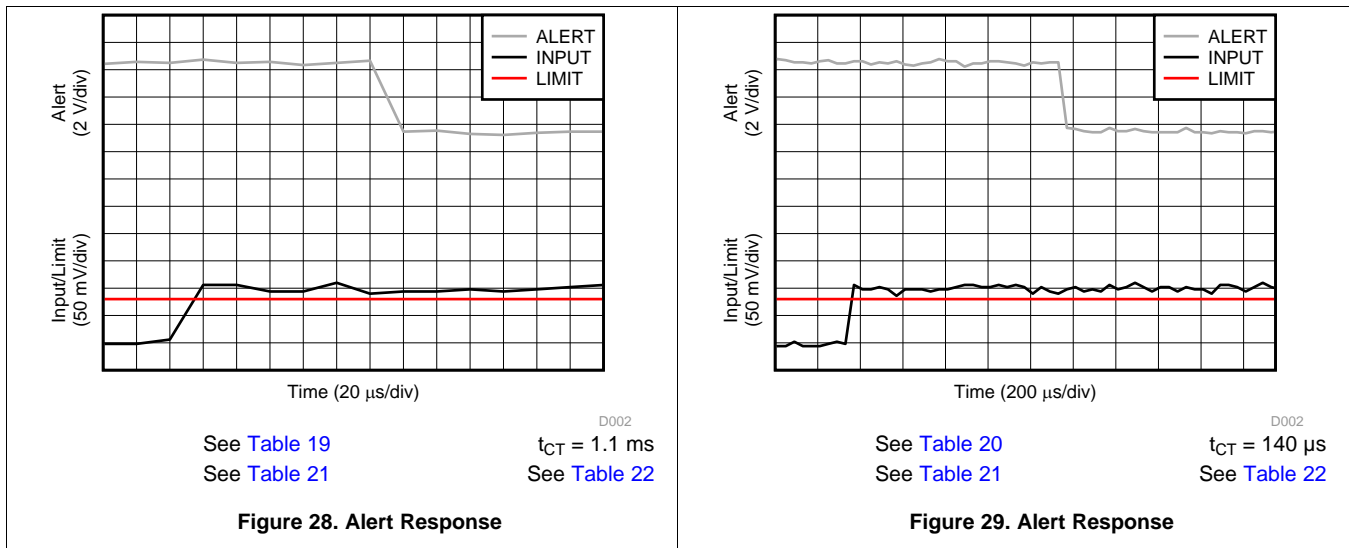

Table 19. Configuration Register (00h) Settings for Figure 28 (Value = 4025h)

BIT #	D15	D14	D13	D12	D11	D10	D9	D8	D7	D6	D5	D4	D3	D2	D1	D0
BIT NAME	RST	—	—	—	AVG2	AVG1	AVG0	VBUSC T2	VBUSC T1	VBUSC T0	V _{SHCT2}	V _{SHCT1}	V _{SHCT0}	MODE3	MODE2	MODE1
POR VALUE	0	1	0	0	0	0	0	0	0	0	1	0	0	1	0	1

Table 20. Configuration Register (00h) Settings for Figure 29 (Value = 4005h)

BIT #	D15	D14	D13	D12	D11	D10	D9	D8	D7	D6	D5	D4	D3	D2	D1	D0
BIT NAME	RST	—	—	—	AVG2	AVG1	AVG0	VBUSC T2	VBUSC T1	VBUSC T0	V _{SHCT2}	V _{SHCT1}	V _{SHCT0}	MODE3	MODE2	MODE1
POR VALUE	0	1	0	0	0	0	0	0	0	0	0	0	0	1	0	1

Table 21. Mask/Enable Register (06h) Settings for Figure 28 and Figure 29 (Value = 8000h)

BIT #	D15	D14	D13	D12	D11	D10	D9	D8	D7	D6	D5	D4	D3	D2	D1	D0
BIT NAME	SOL	SUL	BOL	BUL	POL	CNVR	—	—	—	—	—	AFF	CVRF	OVF	APOL	LEN
POR VALUE	1	0	0	0	0	0	0	0	0	0	0	0	0	0	0	0

Table 22. Alert Limit Register (07h) Settings for Figure 28 and Figure 29 (Value = 7D00)

BIT #	D15	D14	D13	D12	D11	D10	D9	D8	D7	D6	D5	D4	D3	D2	D1	D0
BIT NAME	AUL15	AUL14	AUL13	AUL12	AUL11	AUL10	AUL9	AUL8	AUL7	AUL6	AUL5	AUL4	AUL3	AUL2	AUL1	AUL0
POR VALUE	0	1	1	1	1	1	0	1	0	0	0	0	0	0	0	0

9 Power Supply Recommendations

The input circuitry of the device can accurately measure signals on common-mode voltages beyond its power supply voltage, V_{VS} . For example, the voltage applied to the V_{VS} power supply terminal can be 5 V, whereas the load power-supply voltage being monitored (the common-mode voltage) can be as high as 36 V. Note also that the device can withstand the full 0-V to 36-V range at the input terminals, regardless of whether the device has power applied or not.

Place the required power-supply bypass capacitors as close as possible to the supply and ground terminals of the device to ensure stability. A typical value for this supply bypass capacitor is 0.1 μF . Applications with noisy or high-impedance power supplies may require additional decoupling capacitors to reject power-supply noise.

10 Layout

10.1 Layout Guidelines

Connect the input pins (IN+ and IN-) to the sensing resistor using a Kelvin connection or a 4-wire connection. These connection techniques ensure that only the current-sensing resistor impedance is detected between the input pins. Poor routing of the current-sensing resistor commonly results in additional resistance present between the input pins. Given the very low ohmic value of the current-sensing resistor, any additional high-current carrying impedance causes significant measurement errors. Place the power-supply bypass capacitor as close as possible to the supply and ground pins.

10.2 Layout Example

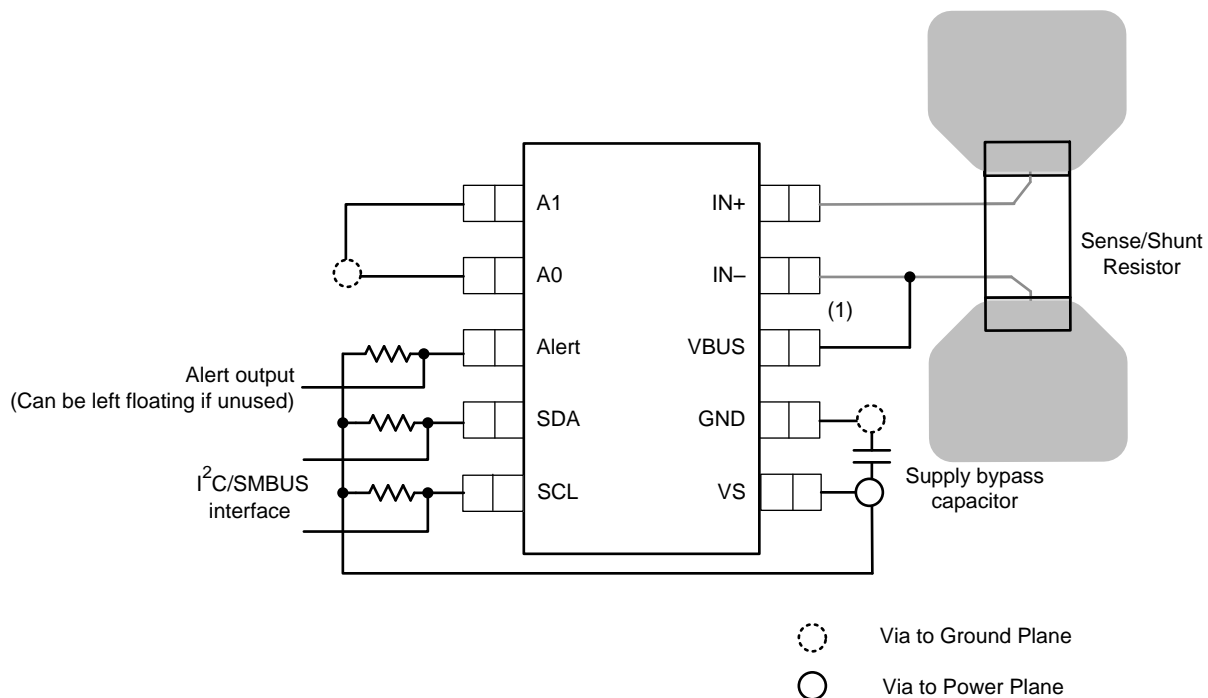

(1) connect the VBUS pin to the power supply rail.

Figure 30. INA226 Layout Example

11 Device and Documentation Support

11.1 Device Support

11.1.1 Development Support

- INA226EVM Evaluation Board and Software Tutorial ([SBOU113](#))

11.2 Community Resources

The following links connect to TI community resources. Linked contents are provided "AS IS" by the respective contributors. They do not constitute TI specifications and do not necessarily reflect TI's views; see TI's [Terms of Use](#).

TI E2E™ Online Community *TI's Engineer-to-Engineer (E2E) Community*. Created to foster collaboration among engineers. At [e2e.ti.com](#), you can ask questions, share knowledge, explore ideas and help solve problems with fellow engineers.

Design Support *TI's Design Support* Quickly find helpful E2E forums along with design support tools and contact information for technical support.

11.3 Trademarks

E2E is a trademark of Texas Instruments.
I²C is a trademark of NXP Semiconductors.
All other trademarks are the property of their respective owners.

11.4 Electrostatic Discharge Caution



These devices have limited built-in ESD protection. The leads should be shorted together or the device placed in conductive foam during storage or handling to prevent electrostatic damage to the MOS gates.

11.5 Glossary

[SLYZ022](#) — *TI Glossary*.

This glossary lists and explains terms, acronyms, and definitions.

12 Mechanical, Packaging, and Orderable Information

The following pages include mechanical, packaging, and orderable information. This information is the most current data available for the designated devices. This data is subject to change without notice and revision of this document. For browser-based versions of this data sheet, refer to the left-hand navigation.

PACKAGING INFORMATION

Orderable Device	Status (1)	Package Type	Package Drawing	Pins	Package Qty	Eco Plan (2)	Lead finish/ Ball material (6)	MSL Peak Temp (3)	Op Temp (°C)	Device Marking (4/5)	Samples
INA226AIDGSR	ACTIVE	VSSOP	DGS	10	2500	RoHS & Green	NIPDAUAG SN	Level-2-260C-1 YEAR	-40 to 125	226	Samples
INA226AIDGST	ACTIVE	VSSOP	DGS	10	250	RoHS & Green	NIPDAUAG SN	Level-2-260C-1 YEAR	-40 to 125	226	Samples

(1) The marketing status values are defined as follows:

ACTIVE: Product device recommended for new designs.

LIFEBUY: TI has announced that the device will be discontinued, and a lifetime-buy period is in effect.

NRND: Not recommended for new designs. Device is in production to support existing customers, but TI does not recommend using this part in a new design.

PREVIEW: Device has been announced but is not in production. Samples may or may not be available.

OBSOLETE: TI has discontinued the production of the device.

(2) **RoHS:** TI defines "RoHS" to mean semiconductor products that are compliant with the current EU RoHS requirements for all 10 RoHS substances, including the requirement that RoHS substance do not exceed 0.1% by weight in homogeneous materials. Where designed to be soldered at high temperatures, "RoHS" products are suitable for use in specified lead-free processes. TI may reference these types of products as "Pb-Free".

RoHS Exempt: TI defines "RoHS Exempt" to mean products that contain lead but are compliant with EU RoHS pursuant to a specific EU RoHS exemption.

Green: TI defines "Green" to mean the content of Chlorine (Cl) and Bromine (Br) based flame retardants meet JS709B low halogen requirements of <=1000ppm threshold. Antimony trioxide based flame retardants must also meet the <=1000ppm threshold requirement.

(3) MSL, Peak Temp. - The Moisture Sensitivity Level rating according to the JEDEC industry standard classifications, and peak solder temperature.

(4) There may be additional marking, which relates to the logo, the lot trace code information, or the environmental category on the device.

(5) Multiple Device Markings will be inside parentheses. Only one Device Marking contained in parentheses and separated by a "~" will appear on a device. If a line is indented then it is a continuation of the previous line and the two combined represent the entire Device Marking for that device.

(6) Lead finish/Ball material - Orderable Devices may have multiple material finish options. Finish options are separated by a vertical ruled line. Lead finish/Ball material values may wrap to two lines if the finish value exceeds the maximum column width.

Important Information and Disclaimer:The information provided on this page represents TI's knowledge and belief as of the date that it is provided. TI bases its knowledge and belief on information provided by third parties, and makes no representation or warranty as to the accuracy of such information. Efforts are underway to better integrate information from third parties. TI has taken and continues to take reasonable steps to provide representative and accurate information but may not have conducted destructive testing or chemical analysis on incoming materials and chemicals. TI and TI suppliers consider certain information to be proprietary, and thus CAS numbers and other limited information may not be available for release.

In no event shall TI's liability arising out of such information exceed the total purchase price of the TI part(s) at issue in this document sold by TI to Customer on an annual basis.

OTHER QUALIFIED VERSIONS OF INA226 :

- Automotive : [INA226-Q1](#)

NOTE: Qualified Version Definitions:

- Automotive - Q100 devices qualified for high-reliability automotive applications targeting zero defects

TAPE AND REEL INFORMATION

QUADRANT ASSIGNMENTS FOR PIN 1 ORIENTATION IN TAPE

*All dimensions are nominal

Device	Package Type	Package Drawing	Pins	SPQ	Reel Diameter (mm)	Reel Width W1 (mm)	A0 (mm)	B0 (mm)	K0 (mm)	P1 (mm)	W (mm)	Pin1 Quadrant
INA226AIDGSR	VSSOP	DGS	10	2500	330.0	12.4	5.3	3.4	1.4	8.0	12.0	Q1
INA226AIDGST	VSSOP	DGS	10	250	330.0	12.4	5.3	3.4	1.4	8.0	12.0	Q1

TAPE AND REEL BOX DIMENSIONS

*All dimensions are nominal

Device	Package Type	Package Drawing	Pins	SPQ	Length (mm)	Width (mm)	Height (mm)
INA226AIDGSR	VSSOP	DGS	10	2500	366.0	364.0	50.0
INA226AIDGST	VSSOP	DGS	10	250	366.0	364.0	50.0

DGS0010A



PACKAGE OUTLINE

VSSOP - 1.1 mm max height

SMALL OUTLINE PACKAGE



4221984/A 05/2015

NOTES:

1. All linear dimensions are in millimeters. Any dimensions in parenthesis are for reference only. Dimensioning and tolerancing per ASME Y14.5M.
2. This drawing is subject to change without notice.
3. This dimension does not include mold flash, protrusions, or gate burrs. Mold flash, protrusions, or gate burrs shall not exceed 0.15 mm per side.
4. This dimension does not include interlead flash. Interlead flash shall not exceed 0.25 mm per side.
5. Reference JEDEC registration MO-187, variation BA.

EXAMPLE BOARD LAYOUT

DGS0010A

VSSOP - 1.1 mm max height

SMALL OUTLINE PACKAGE



LAND PATTERN EXAMPLE
SCALE:10X



SOLDER MASK DETAILS
NOT TO SCALE

4221984/A 05/2015

NOTES: (continued)

- 6. Publication IPC-7351 may have alternate designs.
- 7. Solder mask tolerances between and around signal pads can vary based on board fabrication site.

EXAMPLE STENCIL DESIGN

DGS0010A

VSSOP - 1.1 mm max height

SMALL OUTLINE PACKAGE



SOLDER PASTE EXAMPLE
BASED ON 0.125 mm THICK STENCIL
SCALE:10X

4221984/A 05/2015

NOTES: (continued)

8. Laser cutting apertures with trapezoidal walls and rounded corners may offer better paste release. IPC-7525 may have alternate design recommendations.
9. Board assembly site may have different recommendations for stencil design.

IMPORTANT NOTICE AND DISCLAIMER

TI PROVIDES TECHNICAL AND RELIABILITY DATA (INCLUDING DATA SHEETS), DESIGN RESOURCES (INCLUDING REFERENCE DESIGNS), APPLICATION OR OTHER DESIGN ADVICE, WEB TOOLS, SAFETY INFORMATION, AND OTHER RESOURCES "AS IS" AND WITH ALL FAULTS, AND DISCLAIMS ALL WARRANTIES, EXPRESS AND IMPLIED, INCLUDING WITHOUT LIMITATION ANY IMPLIED WARRANTIES OF MERCHANTABILITY, FITNESS FOR A PARTICULAR PURPOSE OR NON-INFRINGEMENT OF THIRD PARTY INTELLECTUAL PROPERTY RIGHTS.

These resources are intended for skilled developers designing with TI products. You are solely responsible for (1) selecting the appropriate TI products for your application, (2) designing, validating and testing your application, and (3) ensuring your application meets applicable standards, and any other safety, security, regulatory or other requirements.

These resources are subject to change without notice. TI grants you permission to use these resources only for development of an application that uses the TI products described in the resource. Other reproduction and display of these resources is prohibited. No license is granted to any other TI intellectual property right or to any third party intellectual property right. TI disclaims responsibility for, and you will fully indemnify TI and its representatives against, any claims, damages, costs, losses, and liabilities arising out of your use of these resources.

TI's products are provided subject to [TI's Terms of Sale](#) or other applicable terms available either on [ti.com](https://www.ti.com) or provided in conjunction with such TI products. TI's provision of these resources does not expand or otherwise alter TI's applicable warranties or warranty disclaimers for TI products.

TI objects to and rejects any additional or different terms you may have proposed.

Mailing Address: Texas Instruments, Post Office Box 655303, Dallas, Texas 75265
Copyright © 2023, Texas Instruments Incorporated

Looking for pricing, stock, or lifecycle information?

Click below to explore more details on WIN SOURCE:

 [View INA226AIDGSR](#) on WIN SOURCE

 [Texas Instruments](#) Information

Optimize Your Supply Chain with WIN SOURCE Solutions

-  Global Sourcing Solution
-  Obsolete Management
-  Cost Control Management
-  Shortage Management
-  Alternative Solution
-  Excess Inventory Management