



THE DATASHEET OF ESP32-S3-MINI-1-N8



ESP32-S3-MINI-1

ESP32-S3-MINI-1U

Datasheet

Small-sized module supporting 2.4 GHz Wi-Fi (802.11 b/g/n) and Bluetooth® 5 (LE)
Built around ESP32-S3 series of SoCs, Xtensa® dual-core 32-bit LX7 microprocessor
Flash up to 8 MB, optional 2 MB PSRAM in chip package
39 GPIOs, rich set of peripherals
On-board PCB antenna or external antenna connector



ESP32-S3-MINI-1



ESP32-S3-MINI-1U



Version 1.2
Espressif Systems
Copyright © 2023

1 Module Overview

Note:

Check the link or the QR code to make sure that you use the latest version of this document:
https://www.espressif.com/documentation/esp32-s3-mini-1_mini-1u_datasheet_en.pdf



1.1 Features

CPU and On-Chip Memory

- ESP32-S3 embedded, Xtensa® dual-core 32-bit LX7 microprocessor (with single precision FPU), up to 240 MHz
- 384 KB ROM
- 512 KB SRAM
- 16 KB SRAM in RTC
- Up to 8 MB Quad SPI flash
- 2 MB PSRAM (ESP32-S3FH4R2 only)

Wi-Fi

- 802.11 b/g/n
- Bit rate: 802.11n up to 150 Mbps
- A-MPDU and A-MSDU aggregation
- 0.4 μ s guard interval support
- Center frequency range of operating channel: 2412 ~ 2484 MHz

Bluetooth

- Bluetooth LE: Bluetooth 5, Bluetooth mesh
- Speed: 125 Kbps, 500 Kbps, 1 Mbps, 2 Mbps
- Advertising extensions
- Multiple advertisement sets
- Channel selection algorithm #2
- Internal co-existence mechanism between Wi-Fi and Bluetooth to share the same antenna

Peripherals

- GPIO, SPI, LCD interface, Camera interface, UART, I2C, I2S, remote control, pulse counter, LED PWM, full-speed USB 2.0 OTG, USB Serial/JTAG controller, MCPWM, SDIO host, GDMA, TWAI® controller (compatible with ISO 11898-1, i.e. CAN Specification 2.0), ADC, touch sensor, temperature sensor, timers and watchdogs

Note:

* Please refer to [ESP32-S3 Series Datasheet](#) for detailed information about the module peripherals.

Integrated Components on Module

- 40 MHz crystal oscillator

Antenna Options

- On-board PCB antenna (ESP32-S3-MINI-1)
- External antenna via a connector (ESP32-S3-MINI-1U)

Operating Conditions

- Operating voltage/Power supply: 3.0 ~ 3.6 V
- Operating ambient temperature: -40 ~ 85 °C

Certification

- RF certification: See [certificates](#)
- Green certification: RoHS/REACH

Test

- HTOL/HTSL/uHAST/TCT/ESD

1.2 Description

ESP32-S3-MINI-1 and ESP32-S3-MINI-1U are two powerful, generic Wi-Fi + Bluetooth LE MCU modules that feature a rich set of peripherals, yet an optimized size. They are an ideal choice for a wide variety of application scenarios related to Internet of Things (IoT), such as embedded systems, smart home, wearable electronics, etc.

ESP32-S3-MINI-1 comes with a PCB antenna. ESP32-S3-MINI-1U comes with a connector for an external antenna. They feature an up to 8 MB SPI flash and an optional 2 MB SPI Pseudo static RAM (PSRAM). Both ESP32-S3-MINI-1 and ESP32-S3-MINI-1U come in two versions, with the ordering code ending with -N8 and -N4R2 respectively. The two versions only vary in flash and PSRAM size.

The series comparison for the two modules is as follows:

Table 1: ESP32-S3-MINI-1 and ESP32-S3-MINI-1U Series Comparison

Ordering Code	Flash ^{1,2}	PSRAM ¹	Ambient Temp. ³ (°C)	Size ⁴ (mm)
ESP32-S3-MINI-1-N8	8 MB (Quad SPI)	-	-40 ~ 85	15.4 × 20.5 × 2.4
ESP32-S3-MINI-1-N4R2	4 MB (Quad SPI)	2 MB (Quad SPI)		
ESP32-S3-MINI-1U-N8	8 MB (Quad SPI)	-		15.4 × 15.4 × 2.4
ESP32-S3-MINI-1U-N4R2	4 MB (Quad SPI)	2 MB (Quad SPI)		

¹ The modules use flash and PSRAM integrated in the chip's package.

² By default, the SPI flash on the module operates at a maximum clock frequency of 80 MHz and does not support the auto suspend feature. If you have a requirement for a higher flash clock frequency of 120 MHz or if you need the flash auto suspend feature, please [contact us](#).

³ Ambient temperature specifies the recommended temperature range of the environment immediately outside the Espressif module.

⁴ For details, refer to Section [7.1 Physical Dimensions](#).

At the core of the modules is an ESP32-S3, an Xtensa® 32-bit LX7 CPU that operates at up to 240 MHz. You can power off the CPU and make use of the low-power co-processor to constantly monitor the peripherals for changes or crossing of thresholds.

ESP32-S3 integrates a rich set of peripherals including SPI, LCD, Camera interface, UART, I2C, I2S, remote control, pulse counter, LED PWM, USB Serial/Jtag, MCPWM, SDIO host, GDMA, TWAI® controller (compatible with ISO 11898-1, i.e., CAN Specification 2.0), ADC, touch sensor, temperature sensor, timers and watchdogs, as well as up to 45 GPIOs. It also includes a full-speed USB 2.0 On-The-Go (OTG) interface to enable USB communication.

Note:

* For more information on ESP32-S3, please refer to [ESP32-S3 Series Datasheet](#).

1.3 Applications

- Generic Low-power IoT Sensor Hub
- Generic Low-power IoT Data Loggers
- Cameras for Video Streaming
- Over-the-top (OTT) Devices
- USB Devices
- Speech Recognition
- Image Recognition
- Mesh Network
- Home Automation
- Smart Building
- Industrial Automation
- Smart Agriculture
- Audio Applications
- Health Care Applications
- Wi-Fi-enabled Toys
- Wearable Electronics
- Retail & Catering Applications

Contents

1	Module Overview	2
1.1	Features	2
1.2	Description	3
1.3	Applications	4
2	Block Diagram	9
3	Pin Definitions	10
3.1	Pin Layout	10
3.2	Pin Description	11
3.3	Strapping Pins	13
3.3.1	Chip Boot Mode Control	14
3.3.2	VDD_SPI Voltage Control	15
3.3.3	ROM Messages Printing Control	15
3.3.4	JTAG Signal Source Control	15
4	Electrical Characteristics	17
4.1	Absolute Maximum Ratings	17
4.2	Recommended Operating Conditions	17
4.3	DC Characteristics (3.3 V, 25 °C)	17
4.4	Current Consumption Characteristics	18
4.4.1	RF Current Consumption in Active Mode	18
4.4.2	Current Consumption in Other Modes	18
4.5	Wi-Fi RF Characteristics	20
4.5.1	Wi-Fi RF Standards	20
4.5.2	Wi-Fi RF Transmitter (TX) Specifications	20
4.5.3	Wi-Fi RF Receiver (RX) Specifications	21
4.6	Bluetooth LE Radio	22
4.6.1	Bluetooth LE RF Transmitter (TX) Characteristics	23
4.6.2	Bluetooth LE RF Receiver (RX) Characteristics	24
5	Module Schematics	27
6	Peripheral Schematics	29
7	Physical Dimensions and PCB Land Pattern	30
7.1	Physical Dimensions	30
7.2	Recommended PCB Land Pattern	31
7.3	Dimensions of External Antenna Connector	33
8	Product Handling	34
8.1	Storage Conditions	34
8.2	Electrostatic Discharge (ESD)	34

8.3	Soldering Profile	34
8.3.1	Reflow Profile	34
8.4	Ultrasonic Vibration	35
9	Related Documentation and Resources	36
	Revision History	37

List of Tables

1	ESP32-S3-MINI-1 and ESP32-S3-MINI-1U Series Comparison	3
2	Pin Definitions	11
3	Default Configuration of Strapping Pins	13
4	Description of Timing Parameters for the Strapping Pins	14
5	Chip Boot Mode Control	14
6	VDD_SPI Voltage Control	15
7	JTAG Signal Source Control	16
8	Absolute Maximum Ratings	17
9	Recommended Operating Conditions	17
10	DC Characteristics (3.3 V, 25 °C)	17
11	Current Consumption Depending on RF Modes	18
12	Current Consumption in Modem-sleep Mode	19
13	Current Consumption in Low-Power Modes	19
14	Wi-Fi RF Standards	20
15	TX Power with Spectral Mask and EVM Meeting 802.11 Standards	20
16	TX EVM Test	21
17	RX Sensitivity	21
18	Maximum RX Level	22
19	RX Adjacent Channel Rejection	22
20	Bluetooth LE Frequency	22
21	Transmitter Characteristics - Bluetooth LE 1 Mbps	23
22	Transmitter Characteristics - Bluetooth LE 2 Mbps	23
23	Transmitter Characteristics - Bluetooth LE 125 Kbps	23
24	Transmitter Characteristics - Bluetooth LE 500 Kbps	24
25	Receiver Characteristics - Bluetooth LE 1 Mbps	24
26	Receiver Characteristics - Bluetooth LE 2 Mbps	25
27	Receiver Characteristics - Bluetooth LE 125 Kbps	25
28	Receiver Characteristics - Bluetooth LE 500 Kbps	26

List of Figures

1	ESP32-S3-MINI-1 Block Diagram	9
2	ESP32-S3-MINI-1U Block Diagram	9
3	Pin Layout (Top View)	10
4	Visualization of Timing Parameters for the Strapping Pins	14
5	ESP32-S3-MINI-1 Schematics	27
6	ESP32-S3-MINI-1U Schematics	28
7	Peripheral Schematics	29
8	ESP32-S3-MINI-1 Physical Dimensions	30
9	ESP32-S3-MINI-1U Physical Dimensions	30
10	ESP32-S3-MINI-1 Recommended PCB Land Pattern	31
11	ESP32-S3-MINI-1U Recommended PCB Land Pattern	32
12	Dimensions of External Antenna Connector	33
13	Reflow Profile	34

2 Block Diagram

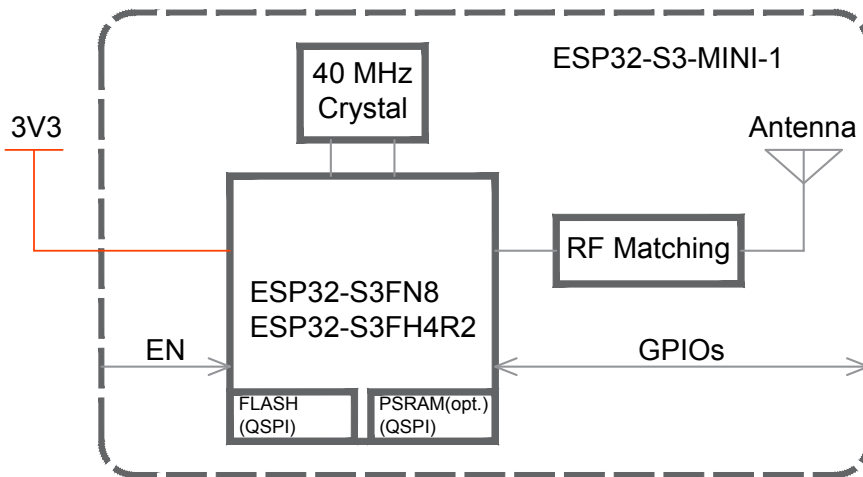

Figure 1: ESP32-S3-MINI-1 Block Diagram

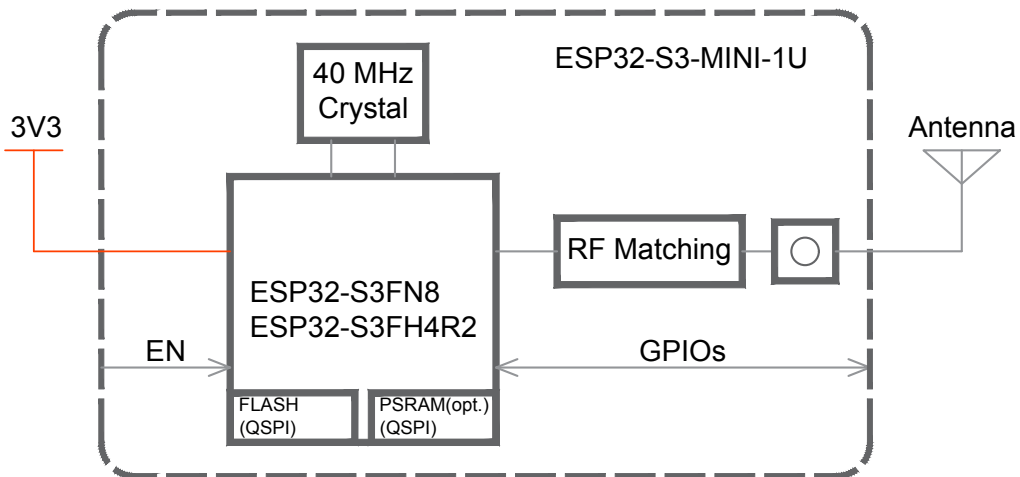

Figure 2: ESP32-S3-MINI-1U Block Diagram

3 Pin Definitions

3.1 Pin Layout

The pin diagram below shows the approximate location of pins on the module. For the actual diagram drawn to scale, please refer to Figure 7.1 *Physical Dimensions*.

The pin diagram is applicable for ESP32-S3-MINI-1 and ESP32-S3-MINI-1U, but the latter has no keepout zone.

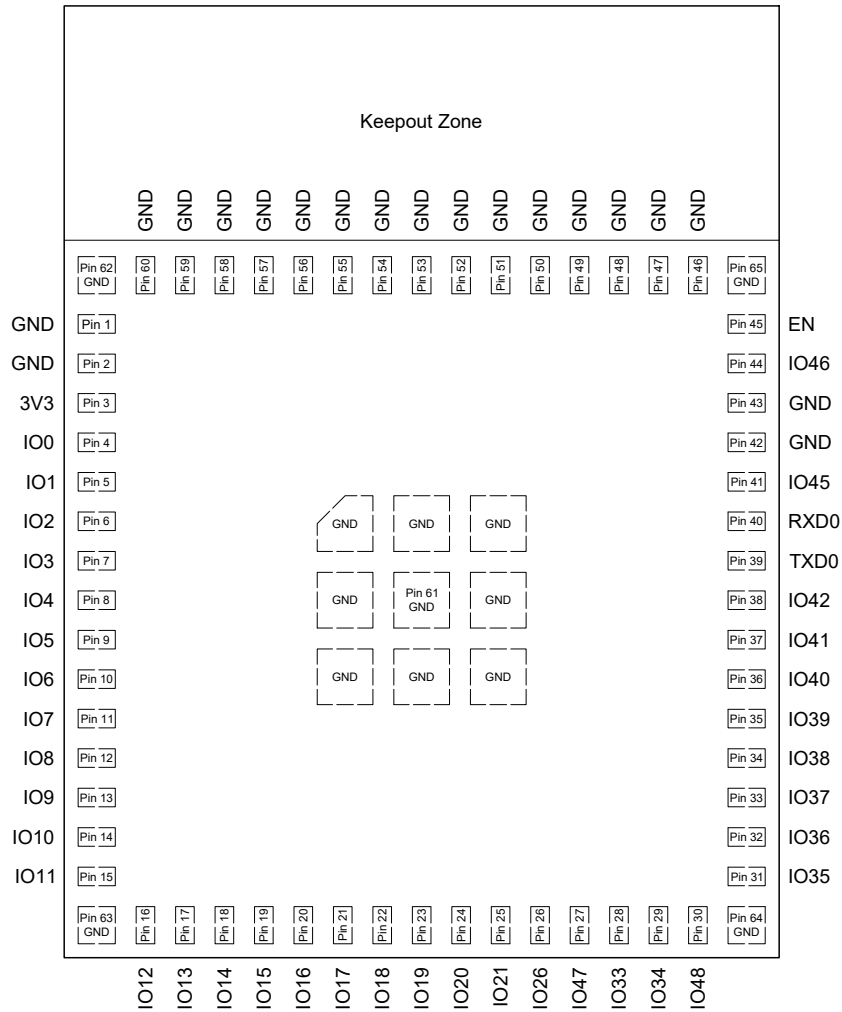

Figure 3: Pin Layout (Top View)

3.2 Pin Description

The module has 65 pins. See pin definitions in Table 2 *Pin Definitions*.

For explanations of pin names and function names, as well as configurations of peripheral pins, please refer to [ESP32-S3](#).

Table 2: Pin Definitions

Name	No.	Type ^a	Function
GND	1, 2, 42, 43, 46-65	P	GND
3V3	3	P	Power supply
IO0	4	I/O/T	RTC_GPIO0, GPIO0
IO1	5	I/O/T	RTC_GPIO1, GPIO1 , TOUCH1, ADC1_CH0
IO2	6	I/O/T	RTC_GPIO2, GPIO2 , TOUCH2, ADC1_CH1
IO3	7	I/O/T	RTC_GPIO3, GPIO3 , TOUCH3, ADC1_CH2
IO4	8	I/O/T	RTC_GPIO4, GPIO4 , TOUCH4, ADC1_CH3
IO5	9	I/O/T	RTC_GPIO5, GPIO5 , TOUCH5, ADC1_CH4
IO6	10	I/O/T	RTC_GPIO6, GPIO6 , TOUCH6, ADC1_CH5
IO7	11	I/O/T	RTC_GPIO7, GPIO7 , TOUCH7, ADC1_CH6
IO8	12	I/O/T	RTC_GPIO8, GPIO8 , TOUCH8, ADC1_CH7, SUBSPICS1
IO9	13	I/O/T	RTC_GPIO9, GPIO9 , TOUCH9, ADC1_CH8, FSPIHD, SUBSPIHD
IO10	14	I/O/T	RTC_GPIO10, GPIO10 , TOUCH10, ADC1_CH9, FSPICS0, FSPIIO4, SUBSPICS0
IO11	15	I/O/T	RTC_GPIO11, GPIO11 , TOUCH11, ADC2_CH0, FSPID, FSPIIO5, SUBSPID
IO12	16	I/O/T	RTC_GPIO12, GPIO12 , TOUCH12, ADC2_CH1, FSPICLK, FSPIIO6, SUBSPICLK
IO13	17	I/O/T	RTC_GPIO13, GPIO13 , TOUCH13, ADC2_CH2, FSPIQ, FSPIIO7, SUBSPIQ
IO14	18	I/O/T	RTC_GPIO14, GPIO14 , TOUCH14, ADC2_CH3, FSPIWP, FSPIDQS, SUBSPIWP
IO15	19	I/O/T	RTC_GPIO15, GPIO15 , U0RTS, ADC2_CH4, XTAL_32K_P
IO16	20	I/O/T	RTC_GPIO16, GPIO16 , U0CTS, ADC2_CH5, XTAL_32K_N
IO17	21	I/O/T	RTC_GPIO17, GPIO17 , U1TXD, ADC2_CH6
IO18	22	I/O/T	RTC_GPIO18, GPIO18 , U1RXD, ADC2_CH7, CLK_OUT3
IO19	23	I/O/T	RTC_GPIO19, GPIO19, U1RTS, ADC2_CH8, CLK_OUT2, USB_D-
IO20	24	I/O/T	RTC_GPIO20, GPIO20, U1CTS, ADC2_CH9, CLK_OUT1, USB_D+
IO21	25	I/O/T	RTC_GPIO21, GPIO21
IO26 ^b	26	I/O/T	SPICS1, GPIO26
IO47	27	I/O/T	SPICLK_P_DIFF, GPIO47 , SUBSPICLK_P_DIFF
IO33	28	I/O/T	SPIIO4, GPIO33 , FSPIHD, SUBSPIHD
IO34	29	I/O/T	SPIIO5, GPIO34 , FSPICS0, SUBSPICS0
IO48	30	I/O/T	SPICLK_N_DIFF, GPIO48 , SUBSPICLK_N_DIFF
IO35	31	I/O/T	SPIIO6, GPIO35 , FSPID, SUBSPID
IO36	32	I/O/T	SPIIO7, GPIO36 , FSPICLK, SUBSPICLK

Cont'd on next page

Table 2 – cont'd from previous page

Name	No.	Type ^a	Function
IO37	33	I/O/T	SPIDQS, GPIO37 , FSPIQ, SUBSPIQ
IO38	34	I/O/T	GPIO38 , FSPIWP, SUBSPIWP
IO39	35	I/O/T	MTCK , GPIO39, CLK_OUT3, SUBSPICS1
IO40	36	I/O/T	MTDO , GPIO40, CLK_OUT2
IO41	37	I/O/T	MTDI , GPIO41, CLK_OUT1
IO42	38	I/O/T	MTMS , GPIO42
TXD0	39	I/O/T	U0TXD , GPIO43, CLK_OUT1
RXD0	40	I/O/T	U0RXD , GPIO44, CLK_OUT2
IO45	41	I/O/T	GPIO45
IO46	44	I/O/T	GPIO46
EN	45	I	High: on, enables the chip. Low: off, the chip powers off. Note: Do not leave the EN pin floating.

^a P: power supply; I: input; O: output; T: high impedance. Pin functions in bold font are the default pin functions.

For pin 28 ~ 29, 31 ~ 33, the default function is decided by eFuse bit.

^b For modules with ordering codes ending with -N4R2, IO26 connects to the embedded PSRAM and is not available for other uses.

3.3 Strapping Pins

Note:

The content below is excerpted from [ESP32-S3 Series Datasheet](#) > Section *Strapping Pins*. For the strapping pin mapping between the chip and modules, please refer to Chapter 5 *Module Schematics*.

At each startup or reset, a module requires some initial configuration parameters, such as in which boot mode to load the module, voltage of flash memory, etc. These parameters are passed over via the strapping pins. After reset, the strapping pins operate as regular IO pins.

The parameters controlled by the given strapping pins at module reset are as follows:

- **Chip boot mode** – GPIO0 and GPIO46
- **VDD_SPI voltage** – GPIO45
- **ROM messages printing** – GPIO46
- **JTAG signal source** – GPIO3

GPIO0, GPIO45, and GPIO46 are connected to the chip's internal weak pull-up/pull-down resistors at chip reset. These resistors determine the default bit values of the strapping pins. Also, these resistors determine the bit values if the strapping pins are connected to an external high-impedance circuit.

Table 3: Default Configuration of Strapping Pins

Strapping Pin	Default Configuration	Bit Value
GPIO0	Pull-up	1
GPIO3	Floating	–
GPIO45	Pull-down	0
GPIO46	Pull-down	0

To change the bit values, the strapping pins should be connected to external pull-down/pull-up resistances. If the ESP32-S3 is used as a device by a host MCU, the strapping pin voltage levels can also be controlled by the host MCU.

All strapping pins have latches. At system reset, the latches sample the bit values of their respective strapping pins and store them until the chip is powered down or shut down. The states of latches cannot be changed in any other way. It makes the strapping pin values available during the entire chip operation, and the pins are freed up to be used as regular IO pins after reset.

Regarding the timing requirements for the strapping pins, there are such parameters as *setup time* and *hold time*. For more information, see Table 4 and Figure 4.

Table 4: Description of Timing Parameters for the Strapping Pins

Parameter	Description	Min (ms)
t_{SU}	<i>Setup time</i> is the time reserved for the power rails to stabilize before the CHIP_PU pin is pulled high to activate the chip.	0
t_H	<i>Hold time</i> is the time reserved for the chip to read the strapping pin values after CHIP_PU is already high and before these pins start operating as regular IO pins.	3

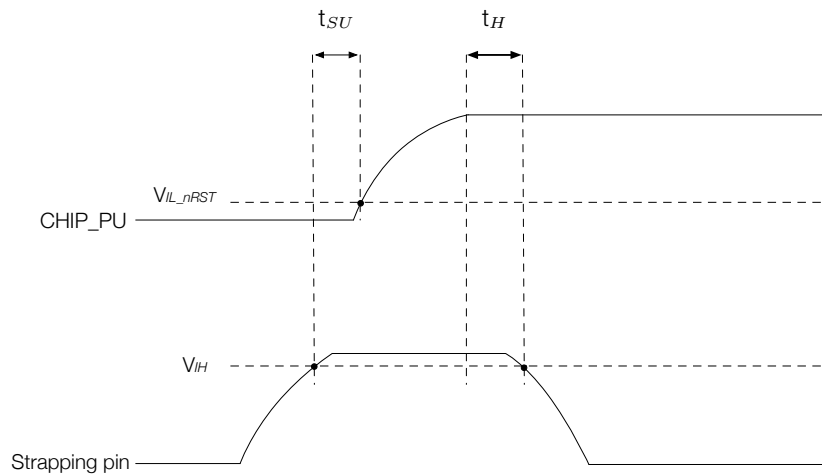
**Figure 4: Visualization of Timing Parameters for the Strapping Pins**

3.3.1 Chip Boot Mode Control

GPIO0 and GPIO46 control the boot mode after the reset is released. See [Table 5 Chip Boot Mode Control](#).

Table 5: Chip Boot Mode Control

Boot Mode	GPIO0	GPIO46
Default Configuration	1 (Pull-up)	0 (Pull-down)
SPI Boot (default)	1	Any value
Joint Download Boot ¹	0	0

¹ Joint Download Boot mode supports the following download methods:

- USB Download Boot:
 - USB-Serial-JTAG Download Boot
 - USB-OTG Download Boot
- UART Download Boot

In SPI Boot mode, the ROM bootloader loads and executes the program from SPI flash to boot the system.

In Joint Download Boot mode, users can download binary files into flash using UART0 or USB interface. It is also possible to download binary files into SRAM and execute it from SRAM.

In addition to SPI Boot and Joint Download Boot modes, ESP32-S3 also supports SPI Download Boot mode. For details, please see [ESP32-S3 Technical Reference Manual](#) > Chapter *Chip Boot Control*.

3.3.2 VDD_SPI Voltage Control

Depending on the value of EFUSE_VDD_SPI_FORCE, the voltage can be controlled in two ways.

Table 6: VDD_SPI Voltage Control

EFUSE_VDD_SPI_FORCE	GPIO45	eFuse ¹	Voltage	VDD_SPI power source ²
0	0	Ignored	3.3 V	VDD3P3_RTC via R _{SPI}
	1		1.8 V	Flash Voltage Regulator
1	Ignored	0	1.8 V	Flash Voltage Regulator
		1	3.3 V	VDD3P3_RTC via R _{SPI}

¹ eFuse: EFUSE_VDD_SPI_TIEH

² See [ESP32-S3 Series Datasheet](#) > Section *Power Scheme*

3.3.3 ROM Messages Printing Control

During boot process the messages by the ROM code can be printed to:

- (Default) UART and USB Serial/JTAG controller.
- USB Serial/JTAG controller.
- UART.

The ROM messages printing to UART or USB Serial/JTAG controller can be respectively disabled by configuring registers and eFuse. For detailed information, please refer to [ESP32-S3 Technical Reference Manual](#) > Chapter *Chip Boot Control*.

3.3.4 JTAG Signal Source Control

The strapping pin GPIO3 can be used to control the source of JTAG signals during the early boot process. This pin does not have any internal pull resistors and the strapping value must be controlled by the external circuit that cannot be in a high impedance state.

As Table 7 shows, GPIO3 is used in combination with EFUSE_DIS_PAD_JTAG, EFUSE_DIS_USB_JTAG, and EFUSE_STRAP_JTAG_SEL.

Table 7: JTAG Signal Source Control

eFuse 1 ^a	eFuse 2 ^b	eFuse 3 ^c	GPIO3	JTAG Signal Source
0	0	0	Ignored	USB Serial/JTAG Controller
		1	0	JTAG pins MTDI, MTCK, MTMS, and MTDO
				1
0	1	Ignored	Ignored	JTAG pins MTDI, MTCK, MTMS, and MTDO
1	0	Ignored	Ignored	USB Serial/JTAG Controller
1	1	Ignored	Ignored	JTAG is disabled

^a eFuse 1: EFUSE_DIS_PAD_JTAG

^b eFuse 2: EFUSE_DIS_USB_JTAG

^c eFuse 3: EFUSE_STRAP_JTAG_SEL

4 Electrical Characteristics

4.1 Absolute Maximum Ratings

Stresses above those listed in Table 8 *Absolute Maximum Ratings* may cause permanent damage to the device. These are stress ratings only and functional operation of the device at these or any other conditions beyond those indicated under Table 9 *Recommended Operating Conditions* is not implied. Exposure to absolute-maximum-rated conditions for extended periods may affect device reliability.

Table 8: Absolute Maximum Ratings

Symbol	Parameter	Min	Max	Unit
VDD33	Power supply voltage	-0.3	3.6	V
T _{STORE}	Storage temperature	-40	105	°C

4.2 Recommended Operating Conditions

Table 9: Recommended Operating Conditions

Symbol	Parameter	Min	Typ	Max	Unit
VDD33	Power supply voltage	3.0	3.3	3.6	V
I _{VDD}	Current delivered by external power supply	0.5	—	—	A
T _A	Operating ambient temperature	-40	—	85	°C

4.3 DC Characteristics (3.3 V, 25 °C)

Table 10: DC Characteristics (3.3 V, 25 °C)

Symbol	Parameter	Min	Typ	Max	Unit
C _{IN}	Pin capacitance	—	2	—	pF
V _{IH}	High-level input voltage	0.75 × VDD ¹	—	VDD ¹ + 0.3	V
V _{IL}	Low-level input voltage	-0.3	—	0.25 × VDD ¹	V
I _{IH}	High-level input current	—	—	50	nA
I _{IL}	Low-level input current	—	—	50	nA
V _{OH} ²	High-level output voltage	0.8 × VDD ¹	—	—	V
V _{OL} ²	Low-level output voltage	—	—	0.1 × VDD ¹	V
I _{OH}	High-level source current (VDD ¹ = 3.3 V, V _{OH} ≥ 2.64 V, PAD_DRIVER = 3)	—	40	—	mA
I _{OL}	Low-level sink current (VDD ¹ = 3.3 V, V _{OL} = 0.495 V, PAD_DRIVER = 3)	—	28	—	mA
R _{PU}	Internal weak pull-up resistor	—	45	—	kΩ
R _{PD}	Internal weak pull-down resistor	—	45	—	kΩ
V _{IH_nRST}	Chip reset release voltage (EN voltage is within the specified range)	0.75 × VDD ¹	—	VDD ¹ + 0.3	V

Cont'd on next page

Table 10 – cont'd from previous page

Symbol	Parameter	Min	Typ	Max	Unit
V_{IL_nRST}	Chip reset voltage (EN voltage is within the specified range)	-0.3	—	$0.25 \times V_{DD}^1$	V

¹ VDD is the I/O voltage for pins of a particular power domain.

² V_{OH} and V_{OL} are measured using high-impedance load.

4.4 Current Consumption Characteristics

4.4.1 RF Current Consumption in Active Mode

With the use of advanced power-management technologies, the module can switch between different power modes. For details on different power modes, please refer to Section *RTC and Low-Power Management* in [ESP32-S3 Series Datasheet](#).

Table 11: Current Consumption Depending on RF Modes

Work mode	Description	Peak (mA)	
Active (RF working)	TX	802.11b, 1 Mbps, @20.5 dBm	355
		802.11g, 54 Mbps, @18 dBm	297
		802.11n, HT20, MCS 7, @17.5 dBm	286
		802.11n, HT40, MCS 7, @17 dBm	285
	RX	802.11b/g/n, HT20	95
		802.11n, HT40	97

¹ The current consumption measurements are taken with a 3.3 V supply at 25 °C of ambient temperature at the RF port. All transmitters' measurements are based on a 100% duty cycle.

² The current consumption figures for in RX mode are for cases when the peripherals are disabled and the CPU idle.

Note:

The content below is excerpted from *Section Power Consumption in Other Modes* in [ESP32-S3 Series Datasheet](#).

4.4.2 Current Consumption in Other Modes

Please note that if the chip embedded has in-package PSRAM, the current consumption of the module might be higher compared to the measurements below.

Table 12: Current Consumption in Modem-sleep Mode

Work mode	Frequency (MHz)	Description	Typ ¹ (mA)	Typ ² (mA)
Modem-sleep ³	40	WAITI (Dual core in idle state)	13.2	18.8
		Single core running 32-bit data access instructions, the other core in idle state	16.2	21.8
		Dual core running 32-bit data access instructions	18.7	24.4
		Single core running 128-bit data access instructions, the other core in idle state	19.9	25.4
		Dual core running 128-bit data access instructions	23.0	28.8
	80	WAITI	22.0	36.1
		Single core running 32-bit data access instructions, the other core in idle state	28.4	42.6
		Dual core running 32-bit data access instructions	33.1	47.3
		Single core running 128-bit data access instructions, the other core in idle state	35.1	49.6
		Dual core running 128-bit data access instructions	41.8	56.3
	160	WAITI	27.6	42.3
		Single core running 32-bit data access instructions, the other core in idle state	39.9	54.6
		Dual core running 32-bit data access instructions	49.6	64.1
		Single core running 128-bit data access instructions, the other core in idle state	54.4	69.2
		Dual core running 128-bit data access instructions	66.7	81.1
	240	WAITI	32.9	47.6
		Single core running 32-bit data access instructions, the other core in idle state	51.2	65.9
		Dual core running 32-bit data access instructions	66.2	81.3
		Single core running 128-bit data access instructions, the other core in idle state	72.4	87.9
		Dual core running 128-bit data access instructions	91.7	107.9

¹ Current consumption when all peripheral clocks are **disabled**.

² Current consumption when all peripheral clocks are **enabled**. In practice, the current consumption might be different depending on which peripherals are enabled.

³ In Modem-sleep mode, Wi-Fi is clock gated, and the current consumption might be higher when accessing flash. For a flash rated at 80 Mbit/s, in SPI 2-line mode the consumption is 10 mA.

Table 13: Current Consumption in Low-Power Modes

Work mode	Description	Typ (μ A)
Light-sleep ¹	VDD_SPI and Wi-Fi are powered down, and all GPIOs are high-impedance.	240
Deep-sleep	RTC memory and RTC peripherals are powered up.	8
	RTC memory is powered up. RTC peripherals are powered down.	7

Power off	CHIP_PU is set to low level. The chip is shut down.	1
-----------	---	---

¹ In Light-sleep mode, all related SPI pins are pulled up. For chips embedded with PSRAM, please add corresponding PSRAM consumption values, e.g., 140 μA for 8 MB Octal PSRAM (3.3 V), 200 μA for 8 MB Octal PSRAM (1.8 V) and 40 μA for 2 MB Quad PSRAM (3.3 V).

4.5 Wi-Fi RF Characteristics

4.5.1 Wi-Fi RF Standards

Table 14: Wi-Fi RF Standards

Name		Description
Center frequency range of operating channel ¹		2412 ~ 2484 MHz
Wi-Fi wireless standard		IEEE 802.11b/g/n
Data rate	20 MHz	11b: 1, 2, 5.5 and 11 Mbps 11g: 6, 9, 12, 18, 24, 36, 48, 54 Mbps 11n: MCS0-7, 72.2 Mbps (Max)
	40 MHz	11n: MCS0-7, 150 Mbps (Max)
Antenna type		PCB antenna, external antenna connector ²

¹ Device should operate in the center frequency range allocated by regional regulatory authorities. Target center frequency range is configurable by software.

² For the modules that use external antenna connectors, the output impedance is 50 Ω . For other modules without external antenna connectors, the output impedance is irrelevant.

4.5.2 Wi-Fi RF Transmitter (TX) Specifications

Target TX power is configurable based on device or certification requirements. The default characteristics are provided in Table 15 *TX Power with Spectral Mask and EVM Meeting 802.11 Standards*.

Table 15: TX Power with Spectral Mask and EVM Meeting 802.11 Standards

Rate	Min (dBm)	Typ (dBm)	Max (dBm)
802.11b, 1 Mbps	—	20.5	—
802.11b, 11 Mbps	—	20.5	—
802.11g, 6 Mbps	—	20.0	—
802.11g, 54 Mbps	—	18.0	—
802.11n, HT20, MCS 0	—	19.0	—
802.11n, HT20, MCS 7	—	17.5	—
802.11n, HT40, MCS 0	—	18.5	—
802.11n, HT40, MCS 7	—	17.0	—

Table 16: TX EVM Test

Rate	Min (dB)	Typ (dB)	SL ¹ (dB)
802.11b, 1 Mbps, @20.5 dBm	—	-24.5	-10
802.11b, 11 Mbps, @20.5 dBm	—	-24.5	-10
802.11g, 6 Mbps, @20 dBm	—	-23.0	-5
802.11g, 54 Mbps, @18 dBm	—	-29.5	-25
802.11n, HT20, MCS 0, @19 dBm	—	-24.0	-5
802.11n, HT20, MCS 7, @17.5 dBm	—	-30.5	-27
802.11n, HT40, MCS 0, @18.5 dBm	—	-25.0	-5
802.11n, HT40, MCS 7, @17 dBm	—	-30.0	-27

¹ SL stands for standard limit value.

4.5.3 Wi-Fi RF Receiver (RX) Specifications

Table 17: RX Sensitivity

Rate	Min (dBm)	Typ (dBm)	Max (dBm)
802.11b, 1 Mbps	—	-98.2	—
802.11b, 2 Mbps	—	-95.6	—
802.11b, 5.5 Mbps	—	-92.8	—
802.11b, 11 Mbps	—	-88.5	—
802.11g, 6 Mbps	—	-93.0	—
802.11g, 9 Mbps	—	-92.0	—
802.11g, 12 Mbps	—	-90.8	—
802.11g, 18 Mbps	—	-88.5	—
802.11g, 24 Mbps	—	-85.5	—
802.11g, 36 Mbps	—	-82.2	—
802.11g, 48 Mbps	—	-78.0	—
802.11g, 54 Mbps	—	-76.2	—
802.11n, HT20, MCS 0	—	-93.0	—
802.11n, HT20, MCS 1	—	-90.6	—
802.11n, HT20, MCS 2	—	-88.4	—
802.11n, HT20, MCS 3	—	-84.8	—
802.11n, HT20, MCS 4	—	-81.6	—
802.11n, HT20, MCS 5	—	-77.4	—
802.11n, HT20, MCS 6	—	-75.6	—
802.11n, HT20, MCS 7	—	-74.2	—
802.11n, HT40, MCS 0	—	-90.0	—
802.11n, HT40, MCS 1	—	-87.5	—
802.11n, HT40, MCS 2	—	-85.0	—
802.11n, HT40, MCS 3	—	-82.0	—

Cont'd on next page

Table 17 – cont'd from previous page

Rate	Min (dBm)	Typ (dBm)	Max (dBm)
802.11n, HT40, MCS 4	—	-78.5	—
802.11n, HT40, MCS 5	—	-74.4	—
802.11n, HT40, MCS 6	—	-72.5	—
802.11n, HT40, MCS 7	—	-71.2	—

Table 18: Maximum RX Level

Rate	Min (dBm)	Typ (dBm)	Max (dBm)
802.11b, 1 Mbps	—	5	—
802.11b, 11 Mbps	—	5	—
802.11g, 6 Mbps	—	5	—
802.11g, 54 Mbps	—	0	—
802.11n, HT20, MCS 0	—	5	—
802.11n, HT20, MCS 7	—	0	—
802.11n, HT40, MCS 0	—	5	—
802.11n, HT40, MCS 7	—	0	—

Table 19: RX Adjacent Channel Rejection

Rate	Min (dB)	Typ (dB)	Max (dB)
802.11b, 1 Mbps	—	35	—
802.11b, 11 Mbps	—	35	—
802.11g, 6 Mbps	—	31	—
802.11g, 54 Mbps	—	14	—
802.11n, HT20, MCS 0	—	31	—
802.11n, HT20, MCS 7	—	13	—
802.11n, HT40, MCS 0	—	19	—
802.11n, HT40, MCS 7	—	8	—

4.6 Bluetooth LE Radio

Table 20: Bluetooth LE Frequency

Parameter	Min (MHz)	Typ (MHz)	Max (MHz)
Center frequency of operating channel	2402	—	2480

4.6.1 Bluetooth LE RF Transmitter (TX) Characteristics

Table 21: Transmitter Characteristics - Bluetooth LE 1 Mbps

Parameter	Description	Min	Typ	Max	Unit
RF transmit power	RF power control range	-24.00	0	21.00	dBm
	Gain control step	—	3.00	—	dB
Carrier frequency offset and drift	Max $ f_n _{n=0, 1, 2, \dots, k}$	—	2.50	—	kHz
	Max $ f_0 - f_n $	—	2.00	—	kHz
	Max $ f_n - f_{n-5} $	—	1.40	—	kHz
	$ f_1 - f_0 $	—	1.00	—	kHz
Modulation characteristics	$\Delta f_{1\text{avg}}$	—	249.00	—	kHz
	Min $\Delta f_{2\text{max}}$ (for at least 99.9% of all $\Delta f_{2\text{max}}$)	—	198.00	—	kHz
	$\Delta f_{2\text{avg}}/\Delta f_{1\text{avg}}$	—	0.86	—	—
In-band spurious emissions	± 2 MHz offset	—	-37.00	—	dBm
	± 3 MHz offset	—	-42.00	—	dBm
	$>\pm 3$ MHz offset	—	-44.00	—	dBm

Table 22: Transmitter Characteristics - Bluetooth LE 2 Mbps

Parameter	Description	Min	Typ	Max	Unit
RF transmit power	RF power control range	-24.00	0	20.00	dBm
	Gain control step	—	3.00	—	dB
Carrier frequency offset and drift	Max $ f_n _{n=0, 1, 2, \dots, k}$	—	2.50	—	kHz
	Max $ f_0 - f_n $	—	2.00	—	kHz
	Max $ f_n - f_{n-5} $	—	1.40	—	kHz
	$ f_1 - f_0 $	—	1.00	—	kHz
Modulation characteristics	$\Delta f_{1\text{avg}}$	—	499.00	—	kHz
	Min $\Delta f_{2\text{max}}$ (for at least 99.9% of all $\Delta f_{2\text{max}}$)	—	416.00	—	kHz
	$\Delta f_{2\text{avg}}/\Delta f_{1\text{avg}}$	—	0.89	—	—
In-band spurious emissions	± 4 MHz offset	—	-42.00	—	dBm
	± 5 MHz offset	—	-44.00	—	dBm
	$>\pm 5$ MHz offset	—	-47.00	—	dBm

Table 23: Transmitter Characteristics - Bluetooth LE 125 Kbps

Parameter	Description	Min	Typ	Max	Unit
RF transmit power	RF power control range	-24.00	0	20.00	dBm
	Gain control step	—	3.00	—	dB
Carrier frequency offset and drift	Max $ f_n _{n=0, 1, 2, \dots, k}$	—	0.80	—	kHz
	Max $ f_0 - f_n $	—	1.00	—	kHz
	$ f_n - f_{n-3} $	—	0.30	—	kHz

Cont'd on next page

Table 23 – cont'd from previous page

Parameter	Description	Min	Typ	Max	Unit
	$ f_0 - f_3 $	—	1.00	—	kHz
Modulation characteristics	Δf_{1avg}	—	248.00	—	kHz
	Min Δf_{1max} (for at least 99.9% of all Δf_{1max})	—	222.00	—	kHz
In-band spurious emissions	± 2 MHz offset	—	-37.00	—	dBm
	± 3 MHz offset	—	-42.00	—	dBm
	$> \pm 3$ MHz offset	—	-44.00	—	dBm

Table 24: Transmitter Characteristics - Bluetooth LE 500 Kbps

Parameter	Description	Min	Typ	Max	Unit
RF transmit power	RF power control range	-24.00	0	20.00	dBm
	Gain control step	—	3.00	—	dB
Carrier frequency offset and drift	Max $ f_n _{n=0, 1, 2, \dots, k}$	—	0.80	—	kHz
	Max $ f_0 - f_n $	—	1.00	—	kHz
	$ f_n - f_{n-3} $	—	0.85	—	kHz
	$ f_0 - f_3 $	—	0.34	—	kHz
Modulation characteristics	Δf_{2avg}	—	213.00	—	kHz
	Min Δf_{2max} (for at least 99.9% of all Δf_{2max})	—	196.00	—	kHz
In-band spurious emissions	± 2 MHz offset	—	-37.00	—	dBm
	± 3 MHz offset	—	-42.00	—	dBm
	$> \pm 3$ MHz offset	—	-44.00	—	dBm

4.6.2 Bluetooth LE RF Receiver (RX) Characteristics

Table 25: Receiver Characteristics - Bluetooth LE 1 Mbps

Parameter	Description	Min	Typ	Max	Unit
Sensitivity @30.8% PER	—	—	-96.5	—	dBm
Maximum received signal @30.8% PER	—	—	8	—	dBm
Co-channel C/I	F = F0 MHz	—	8	—	dB
Adjacent channel selectivity C/I	F = F0 + 1 MHz	—	4	—	dB
	F = F0 - 1 MHz	—	4	—	dB
	F = F0 + 2 MHz	—	-23	—	dB
	F = F0 - 2 MHz	—	-23	—	dB
	F = F0 + 3 MHz	—	-34	—	dB
	F = F0 - 3 MHz	—	-34	—	dB
	F > F0 + 3 MHz	—	-36	—	dB
	F > F0 - 3 MHz	—	-37	—	dB
Image frequency	—	—	-36	—	dB

Cont'd on next page

Table 25 – cont'd from previous page

Parameter	Description	Min	Typ	Max	Unit
Adjacent channel to image frequency	$F = F_{image} + 1 \text{ MHz}$	—	-39	—	dB
	$F = F_{image} - 1 \text{ MHz}$	—	-34	—	dB
Out-of-band blocking performance	30 MHz ~ 2000 MHz	—	-12	—	dBm
	2003 MHz ~ 2399 MHz	—	-18	—	dBm
	2484 MHz ~ 2997 MHz	—	-16	—	dBm
	3000 MHz ~ 12.75 GHz	—	-10	—	dBm
Intermodulation	—	—	-29	—	dBm

Table 26: Receiver Characteristics - Bluetooth LE 2 Mbps

Parameter	Description	Min	Typ	Max	Unit
Sensitivity @30.8% PER	—	—	-92	—	dBm
Maximum received signal @30.8% PER	—	—	3	—	dBm
Co-channel C/I	$F = F_0 \text{ MHz}$	—	8	—	dB
Adjacent channel selectivity C/I	$F = F_0 + 2 \text{ MHz}$	—	4	—	dB
	$F = F_0 - 2 \text{ MHz}$	—	4	—	dB
	$F = F_0 + 4 \text{ MHz}$	—	-27	—	dB
	$F = F_0 - 4 \text{ MHz}$	—	-27	—	dB
	$F = F_0 + 6 \text{ MHz}$	—	-38	—	dB
	$F = F_0 - 6 \text{ MHz}$	—	-38	—	dB
	$F > F_0 + 6 \text{ MHz}$	—	-41	—	dB
Image frequency	—	—	-27	—	dB
Adjacent channel to image frequency	$F = F_{image} + 2 \text{ MHz}$	—	-38	—	dB
	$F = F_{image} - 2 \text{ MHz}$	—	4	—	dB
Out-of-band blocking performance	30 MHz ~ 2000 MHz	—	-15	—	dBm
	2003 MHz ~ 2399 MHz	—	-21	—	dBm
	2484 MHz ~ 2997 MHz	—	-21	—	dBm
	3000 MHz ~ 12.75 GHz	—	-9	—	dBm
Intermodulation	—	—	-29	—	dBm

Table 27: Receiver Characteristics - Bluetooth LE 125 Kbps

Parameter	Description	Min	Typ	Max	Unit
Sensitivity @30.8% PER	—	—	-103.5	—	dBm
Maximum received signal @30.8% PER	—	—	8	—	dBm
Co-channel C/I	$F = F_0 \text{ MHz}$	—	4	—	dB
Adjacent channel selectivity C/I	$F = F_0 + 1 \text{ MHz}$	—	1	—	dB
	$F = F_0 - 1 \text{ MHz}$	—	2	—	dB
	$F = F_0 + 2 \text{ MHz}$	—	-26	—	dB
	$F = F_0 - 2 \text{ MHz}$	—	-26	—	dB
	$F = F_0 + 3 \text{ MHz}$	—	-36	—	dB
	$F = F_0 - 3 \text{ MHz}$	—	-39	—	dB

Cont'd on next page

Table 27 – cont'd from previous page

Parameter	Description	Min	Typ	Max	Unit
	$F > F_0 + 3 \text{ MHz}$	—	-42	—	dB
	$F > F_0 - 3 \text{ MHz}$	—	-43	—	dB
Image frequency	—	—	-42	—	dB
Adjacent channel to image frequency	$F = F_{image} + 1 \text{ MHz}$	—	-43	—	dB
	$F = F_{image} - 1 \text{ MHz}$	—	-36	—	dB

Table 28: Receiver Characteristics - Bluetooth LE 500 Kbps

Parameter	Description	Min	Typ	Max	Unit
Sensitivity @30.8% PER	—	—	-100	—	dBm
Maximum received signal @30.8% PER	—	—	8	—	dBm
Co-channel C/I	$F = F_0 \text{ MHz}$	—	4	—	dB
Adjacent channel selectivity C/I	$F = F_0 + 1 \text{ MHz}$	—	1	—	dB
	$F = F_0 - 1 \text{ MHz}$	—	0	—	dB
	$F = F_0 + 2 \text{ MHz}$	—	-24	—	dB
	$F = F_0 - 2 \text{ MHz}$	—	-24	—	dB
	$F = F_0 + 3 \text{ MHz}$	—	-37	—	dB
	$F = F_0 - 3 \text{ MHz}$	—	-39	—	dB
	$F > F_0 + 3 \text{ MHz}$	—	-38	—	dB
	$F > F_0 - 3 \text{ MHz}$	—	-42	—	dB
Image frequency	—	—	-38	—	dB
Adjacent channel to image frequency	$F = F_{image} + 1 \text{ MHz}$	—	-42	—	dB
	$F = F_{image} - 1 \text{ MHz}$	—	-37	—	dB

5 Module Schematics

This is the reference design of the module.

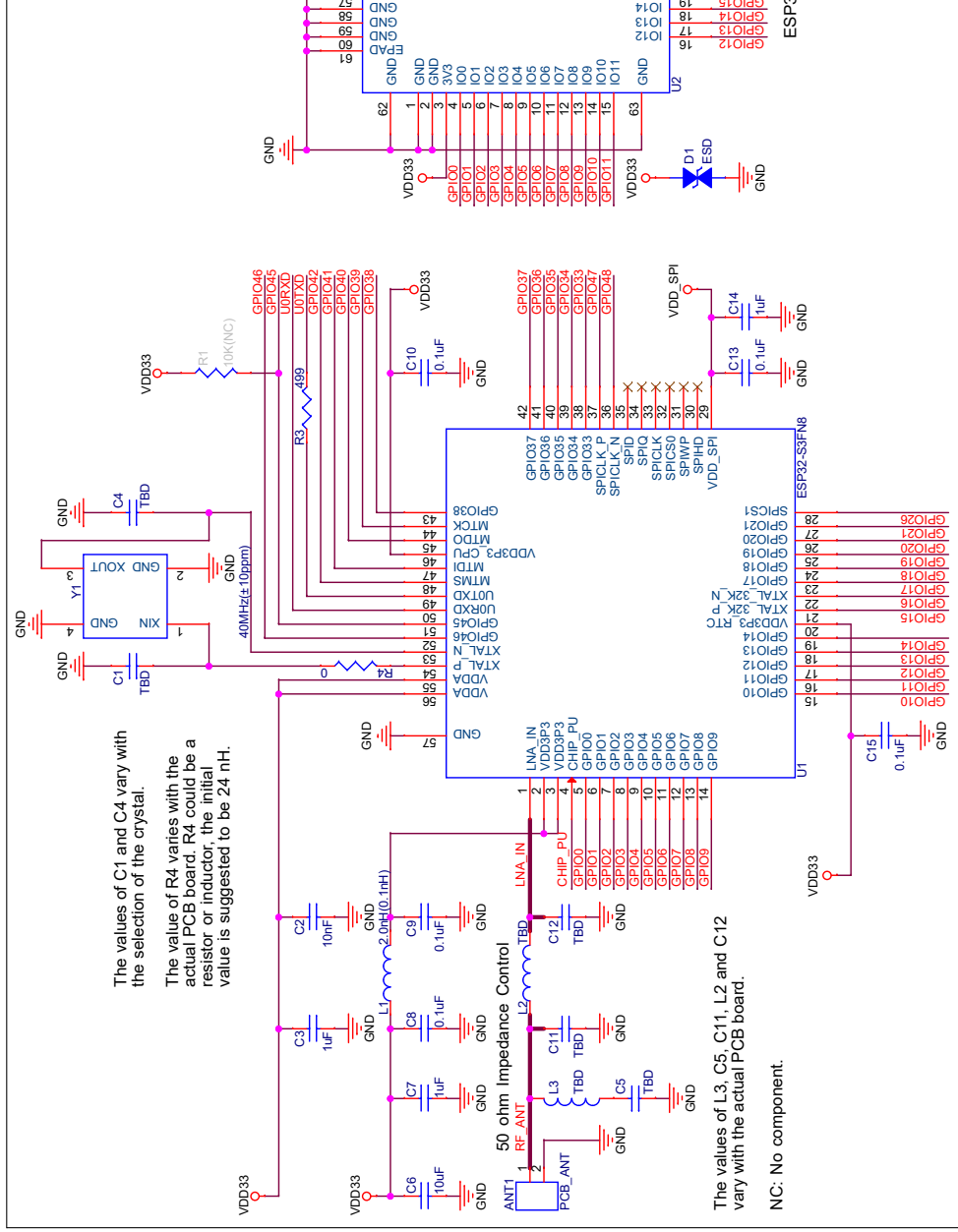

Figure 5: ESP32-S3-MINI-1 Schematics

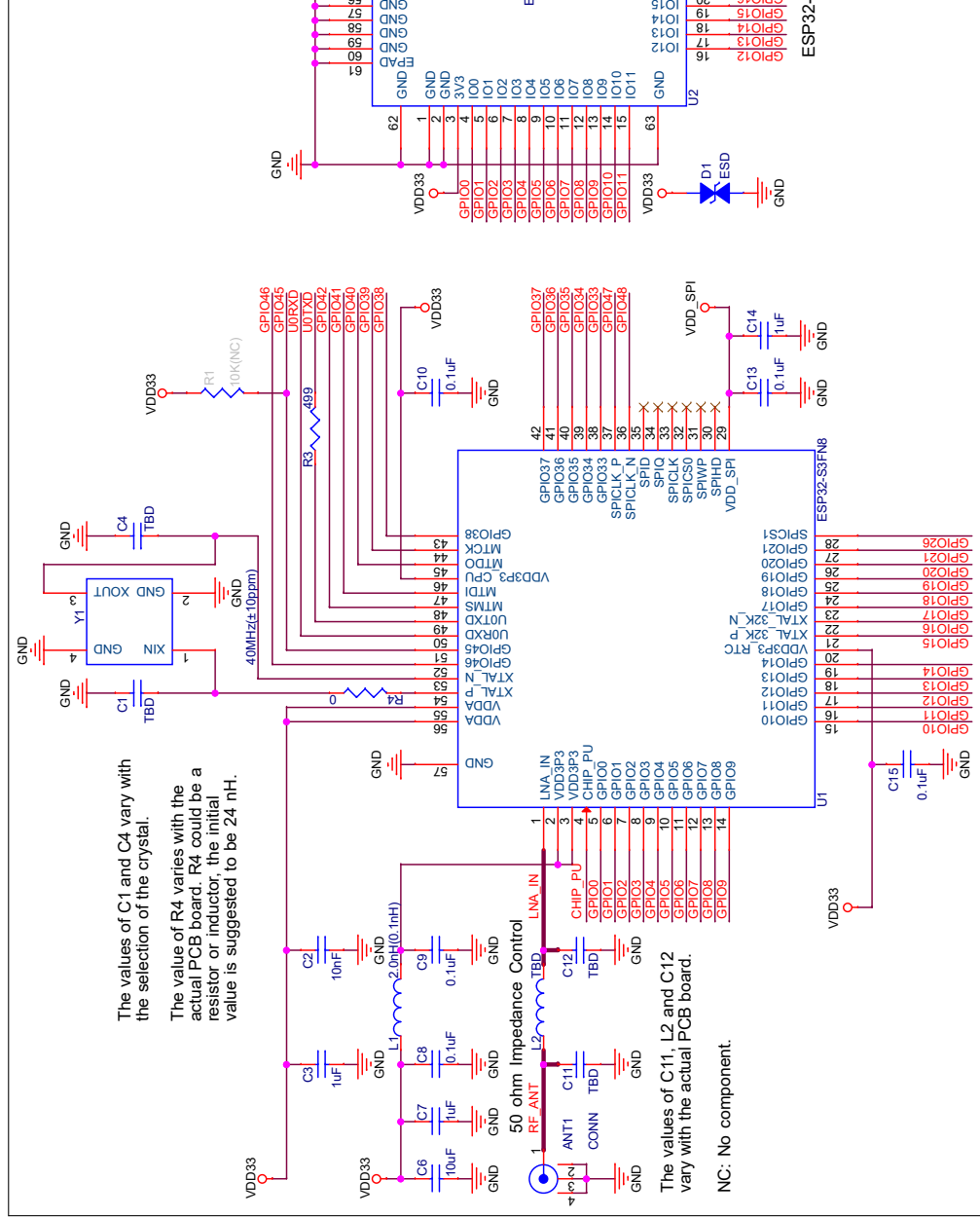

Figure 6: ESP32-S3-MINI-1U Schematics

7 Physical Dimensions and PCB Land Pattern

7.1 Physical Dimensions

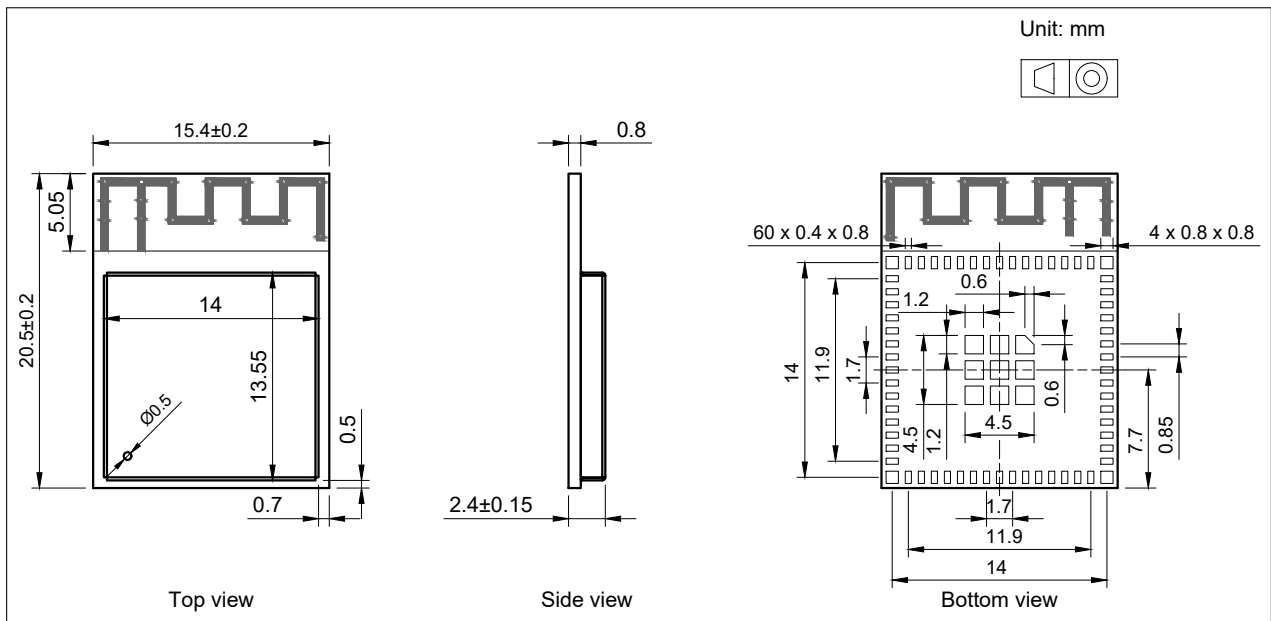

Figure 8: ESP32-S3-MINI-1 Physical Dimensions

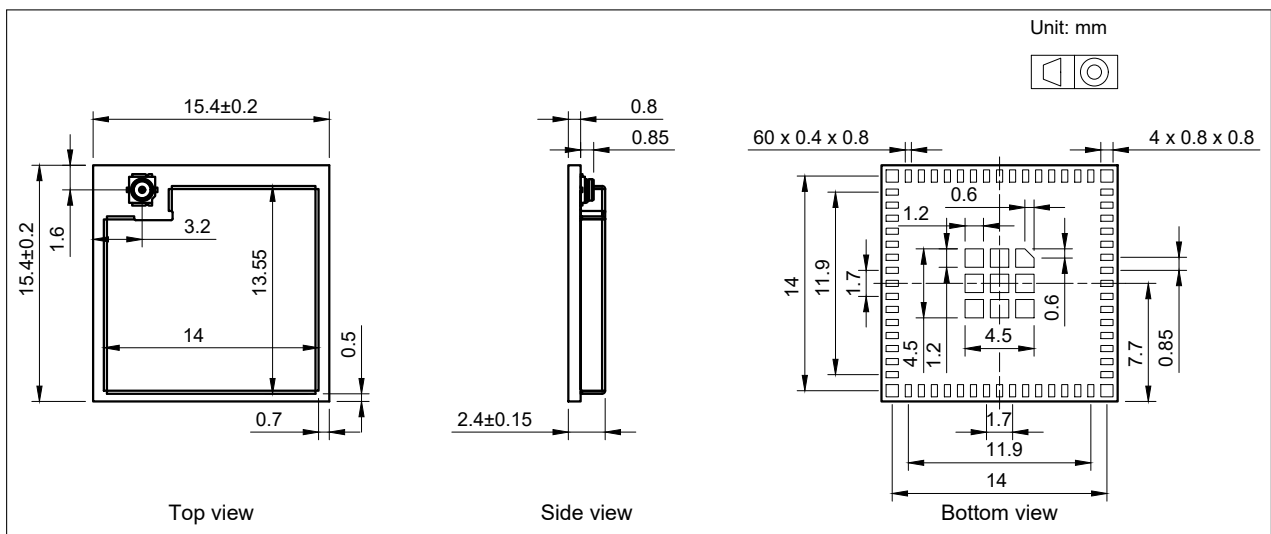

Figure 9: ESP32-S3-MINI-1U Physical Dimensions

Note:

For information about tape, reel, and product marking, please refer to [Espressif Module Packaging Information](#).

7.2 Recommended PCB Land Pattern

This section provides the following resources for your reference:

- Figures for recommended PCB land patterns with all the dimensions needed for PCB design. See Figure 10 *ESP32-S3-MINI-1 Recommended PCB Land Pattern* and Figure 11 *ESP32-S3-MINI-1U Recommended PCB Land Pattern*.
- Source files of recommended PCB land patterns to measure dimensions not covered in Figure 10 and Figure 11. You can view the source files for [ESP32-S3-MINI-1](#) and [ESP32-S3-MINI-1U](#) with [Autodesk Viewer](#).
- 3D models of [ESP32-S3-MINI-1](#). Please make sure that you download the 3D model file in .STEP format (beware that some browsers might add .txt).

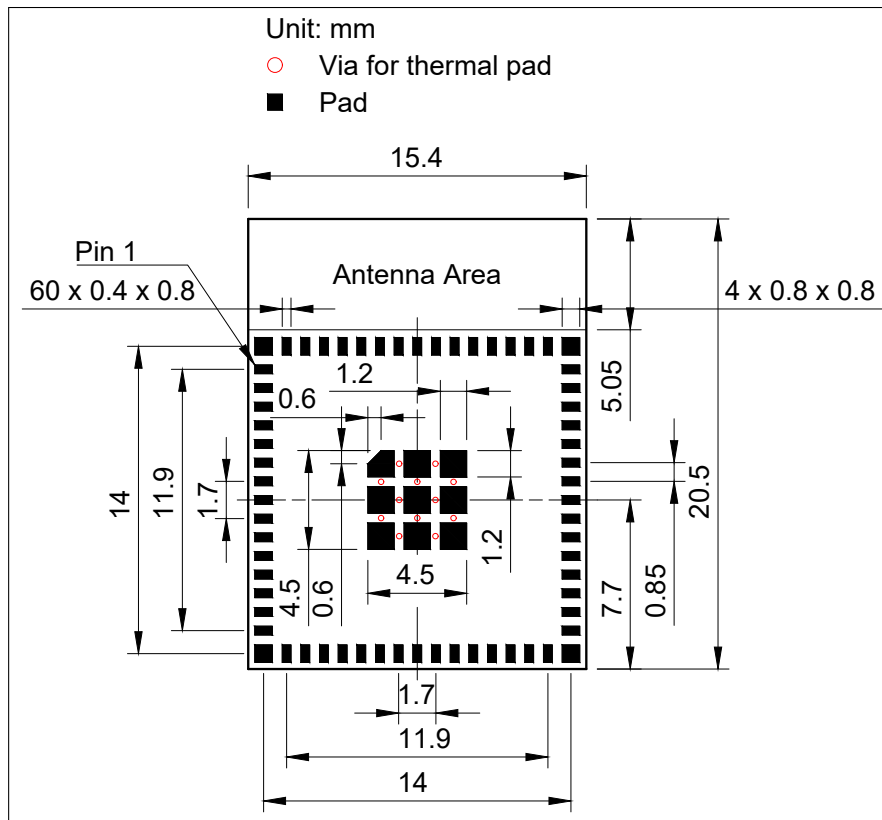

Figure 10: ESP32-S3-MINI-1 Recommended PCB Land Pattern

7.3 Dimensions of External Antenna Connector

ESP32-S3-MINI-1U uses the third generation external antenna connector as shown in Figure 12 *Dimensions of External Antenna Connector*. This connector is compatible with the following connectors:

- W.FL Series connector from Hirose
- MHF III connector from I-PEX
- AMMC connector from Amphenol

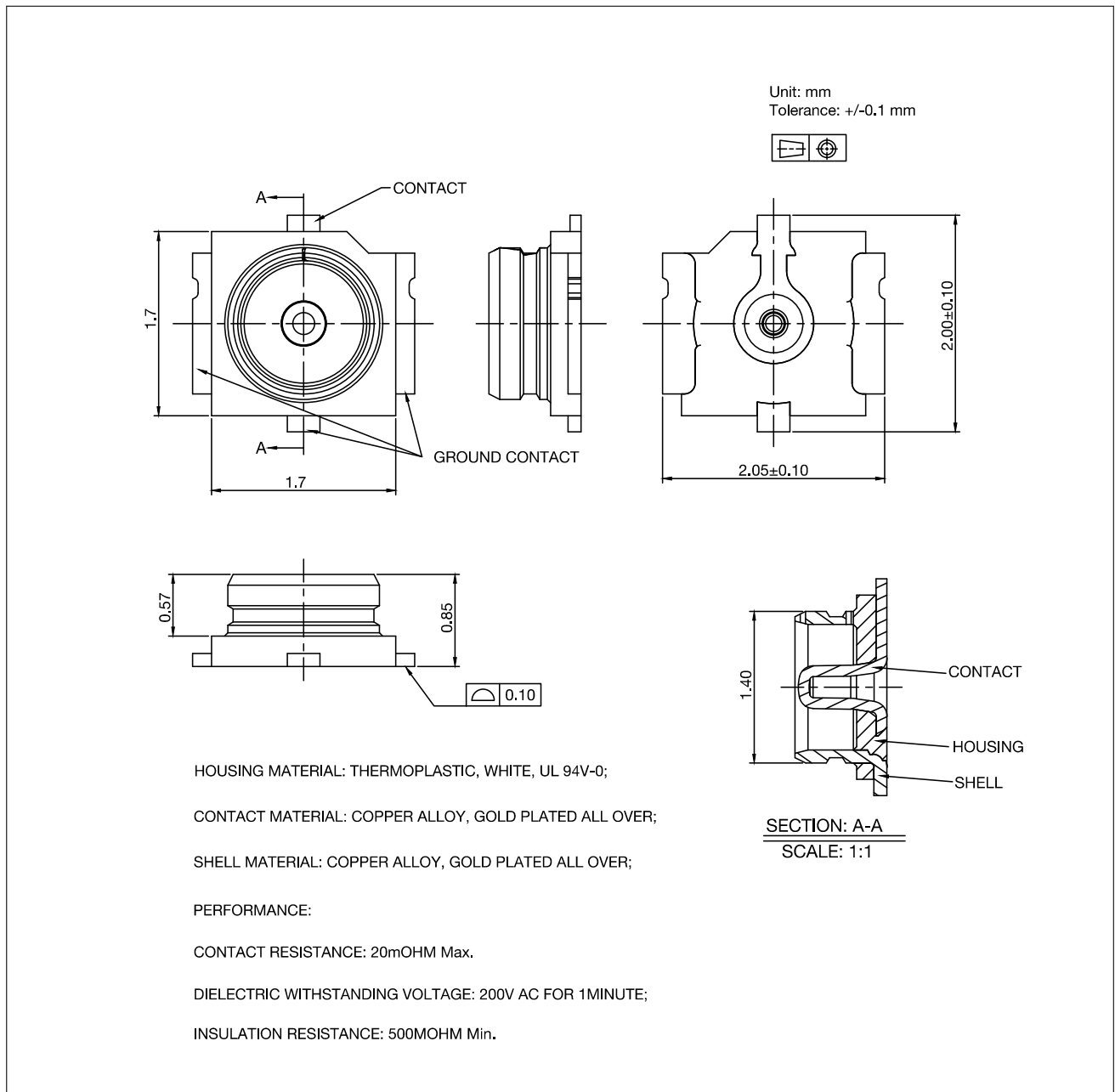

Figure 12: Dimensions of External Antenna Connector

8 Product Handling

8.1 Storage Conditions

The products sealed in moisture barrier bags (MBB) should be stored in a non-condensing atmospheric environment of $< 40\text{ }^{\circ}\text{C}$ and 90%RH. The module is rated at the moisture sensitivity level (MSL) of 3.

After unpacking, the module must be soldered within 168 hours with the factory conditions $25\pm 5\text{ }^{\circ}\text{C}$ and 60%RH. If the above conditions are not met, the module needs to be baked.

8.2 Electrostatic Discharge (ESD)

- Human body model (HBM): $\pm 2000\text{ V}$
- Charged-device model (CDM): $\pm 500\text{ V}$

8.3 Soldering Profile

8.3.1 Reflow Profile

Solder the module in a single reflow.

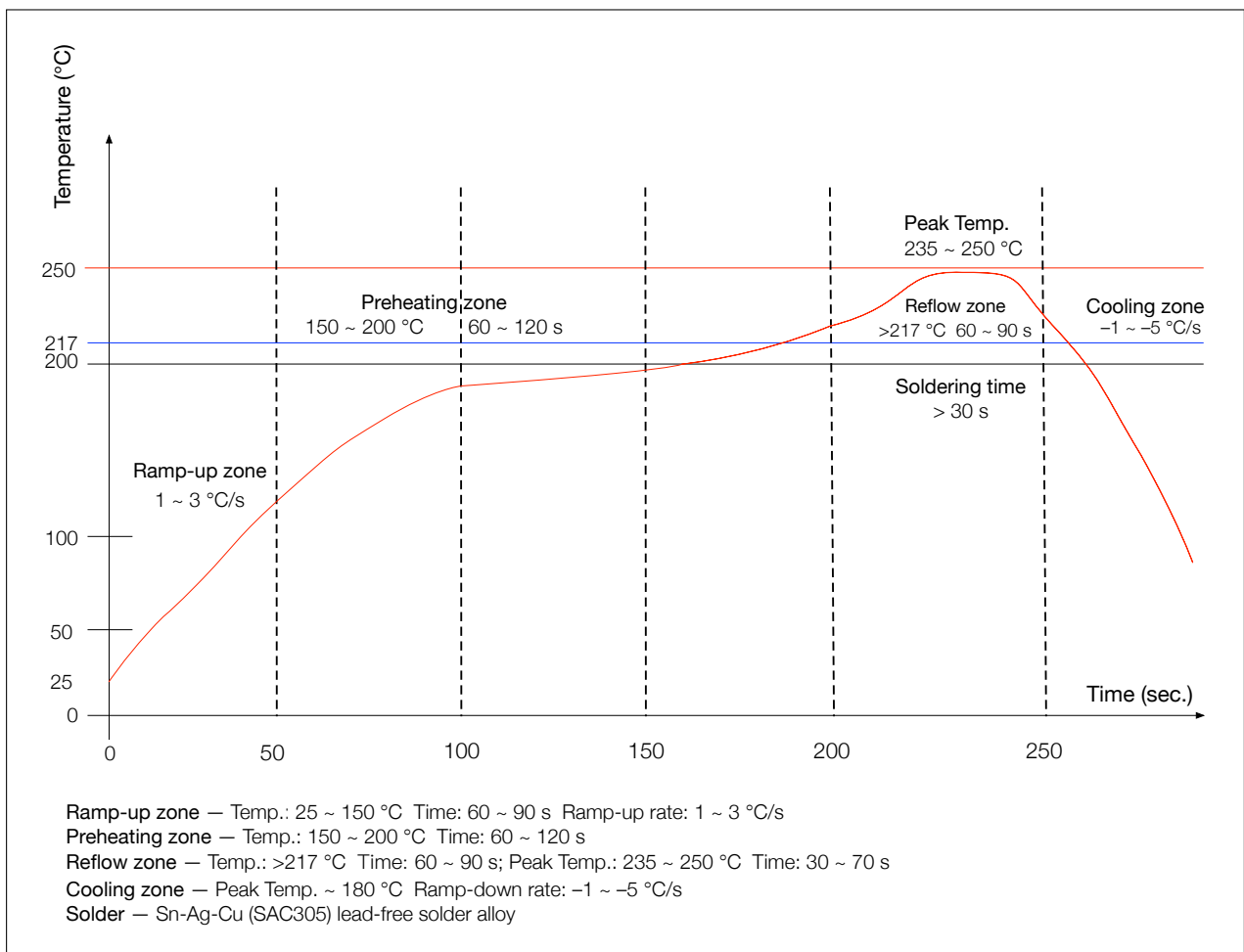

Figure 13: Reflow Profile

8.4 Ultrasonic Vibration

Avoid exposing Espressif modules to vibration from ultrasonic equipment, such as ultrasonic welders or ultrasonic cleaners. This vibration may induce resonance in the in-module crystal and lead to its malfunction or even failure. As a consequence, **the module may stop working or its performance may deteriorate.**

9 Related Documentation and Resources

Related Documentation

- [ESP32-S3 Series Datasheet](#) – Specifications of the ESP32-S3 hardware.
- [ESP32-S3 Technical Reference Manual](#) – Detailed information on how to use the ESP32-S3 memory and peripherals.
- [ESP32-S3 Hardware Design Guidelines](#) – Guidelines on how to integrate the ESP32-S3 into your hardware product.
- [ESP32-S3 Series SoC Errata](#) – Descriptions of known errors in ESP32-S3 series of SoCs.
- *Certificates*
<https://espressif.com/en/support/documents/certificates>
- *ESP32-S3 Product/Process Change Notifications (PCN)*
<https://espressif.com/en/support/documents/pcns?keys=ESP32-S3>
- *ESP32-S3 Advisories* – Information on security, bugs, compatibility, component reliability.
<https://espressif.com/en/support/documents/advisories?keys=ESP32-S3>
- *Documentation Updates and Update Notification Subscription*
<https://espressif.com/en/support/download/documents>

Developer Zone

- [ESP-IDF Programming Guide for ESP32-S3](#) – Extensive documentation for the ESP-IDF development framework.
- *ESP-IDF* and other development frameworks on GitHub.
<https://github.com/espressif>
- *ESP32 BBS Forum* – Engineer-to-Engineer (E2E) Community for Espressif products where you can post questions, share knowledge, explore ideas, and help solve problems with fellow engineers.
<https://esp32.com/>
- *The ESP Journal* – Best Practices, Articles, and Notes from Espressif folks.
<https://blog.espressif.com/>
- See the tabs *SDKs and Demos, Apps, Tools, AT Firmware*.
<https://espressif.com/en/support/download/sdks-demos>

Products

- *ESP32-S3 Series SoCs* – Browse through all ESP32-S3 SoCs.
<https://espressif.com/en/products/socs?id=ESP32-S3>
- *ESP32-S3 Series Modules* – Browse through all ESP32-S3-based modules.
<https://espressif.com/en/products/modules?id=ESP32-S3>
- *ESP32-S3 Series DevKits* – Browse through all ESP32-S3-based devkits.
<https://espressif.com/en/products/devkits?id=ESP32-S3>
- *ESP Product Selector* – Find an Espressif hardware product suitable for your needs by comparing or applying filters.
<https://products.espressif.com/#/product-selector?language=en>

Contact Us

- See the tabs *Sales Questions, Technical Enquiries, Circuit Schematic & PCB Design Review, Get Samples* (Online stores), *Become Our Supplier, Comments & Suggestions*.
<https://espressif.com/en/contact-us/sales-questions>

Revision History

Date	Version	Release notes
2023-11-24	v1.2	<ul style="list-style-type: none"> Removed the table note about ESP32-S3FH4R2 sample status from Table 1 ESP32-S3-MINI-1 and ESP32-S3-MINI-1U Series Comparison and added the second table note Updated Section 3.3.1 Chip Boot Mode Control Updated the module schematics in Section 5 Module Schematics Updated the physical dimensions figure in Section 7.1 Physical Dimensions Updated the recommended PCB land pattern figure in Section 7.2 Recommended PCB Land Pattern Other minor updates
2023-03-07	v1.1	<ul style="list-style-type: none"> Remove module variants ESP32-S3-MINI-1-H4R2 and ESP32-S3-MINI-1U-H4R2 Update the descriptions and Table 1 ESP32-S3-MINI-1 and ESP32-S3-MINI-1U Series Comparison in Section 1.2 Description Update Section 3.3 Strapping Pins Update Section 4.4 Current Consumption Characteristics Update the minimum value of RF transmit power in Section 4.6.1 Bluetooth LE RF Transmitter (TX) Characteristics Update descriptions in Section 6 Peripheral Schematics Add descriptions in Section 7.2 Recommended PCB Land Pattern Update Section 9 Related Documentation and Resources Other minor updates
2022-05-24	v1.0	<ul style="list-style-type: none"> Update information about flash and PSRAM on the title page and in Section 1.1 Add certification and test information Add information of new module variants and their ambient operating temperature versions in Table 1 Add the second note in Table 2 Update Section 3.3 Add notes in Table 13 Update Bluetooth LE RF data Update module schematics in Section 5 Other minor updates
2021-11-16	v0.6	Overall update for chip revision 1
2021-03-30	v0.1	Preliminary release, for chip revision 0



www.espressif.com

Disclaimer and Copyright Notice

Information in this document, including URL references, is subject to change without notice.

ALL THIRD PARTY'S INFORMATION IN THIS DOCUMENT IS PROVIDED AS IS WITH NO WARRANTIES TO ITS AUTHENTICITY AND ACCURACY.

NO WARRANTY IS PROVIDED TO THIS DOCUMENT FOR ITS MERCHANTABILITY, NON-INFRINGEMENT, FITNESS FOR ANY PARTICULAR PURPOSE, NOR DOES ANY WARRANTY OTHERWISE ARISING OUT OF ANY PROPOSAL, SPECIFICATION OR SAMPLE.

All liability, including liability for infringement of any proprietary rights, relating to use of information in this document is disclaimed. No licenses express or implied, by estoppel or otherwise, to any intellectual property rights are granted herein.



The Wi-Fi Alliance Member logo is a trademark of the Wi-Fi Alliance. The Bluetooth logo is a registered trademark of Bluetooth SIG.

All trade names, trademarks and registered trademarks mentioned in this document are property of their respective owners, and are hereby acknowledged.





Copyright © 2023 Espressif Systems (Shanghai) Co., Ltd. All rights reserved.

Looking for pricing, stock, or lifecycle information?

Click below to explore more details on WIN SOURCE:

-  [View ESP32-S3-MINI-1-N8 on WIN SOURCE](#)
-  [Espressif Information](#)

Optimize Your Supply Chain with WIN SOURCE Solutions

-  Global Sourcing Solution
-  Obsolete Management
-  Cost Control Management
-  Shortage Management
-  Alternative Solution
-  Excess Inventory Management